

# Соосные – Редукторы

Coaxial Gear Boxes

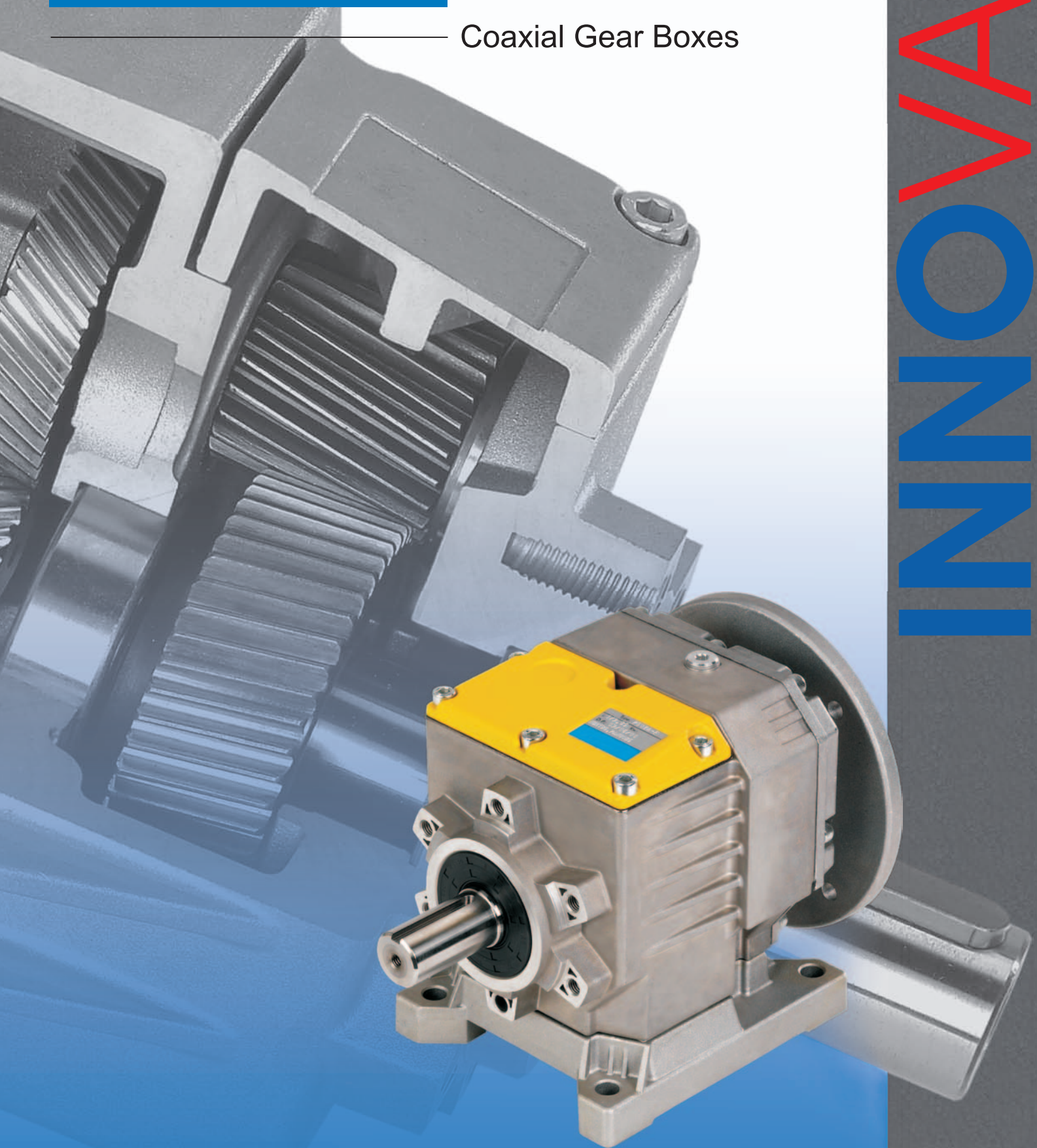

INNOVARI

0.18÷7.5 кВт / 50÷460 Нм



# Алюминиевые и чугунные

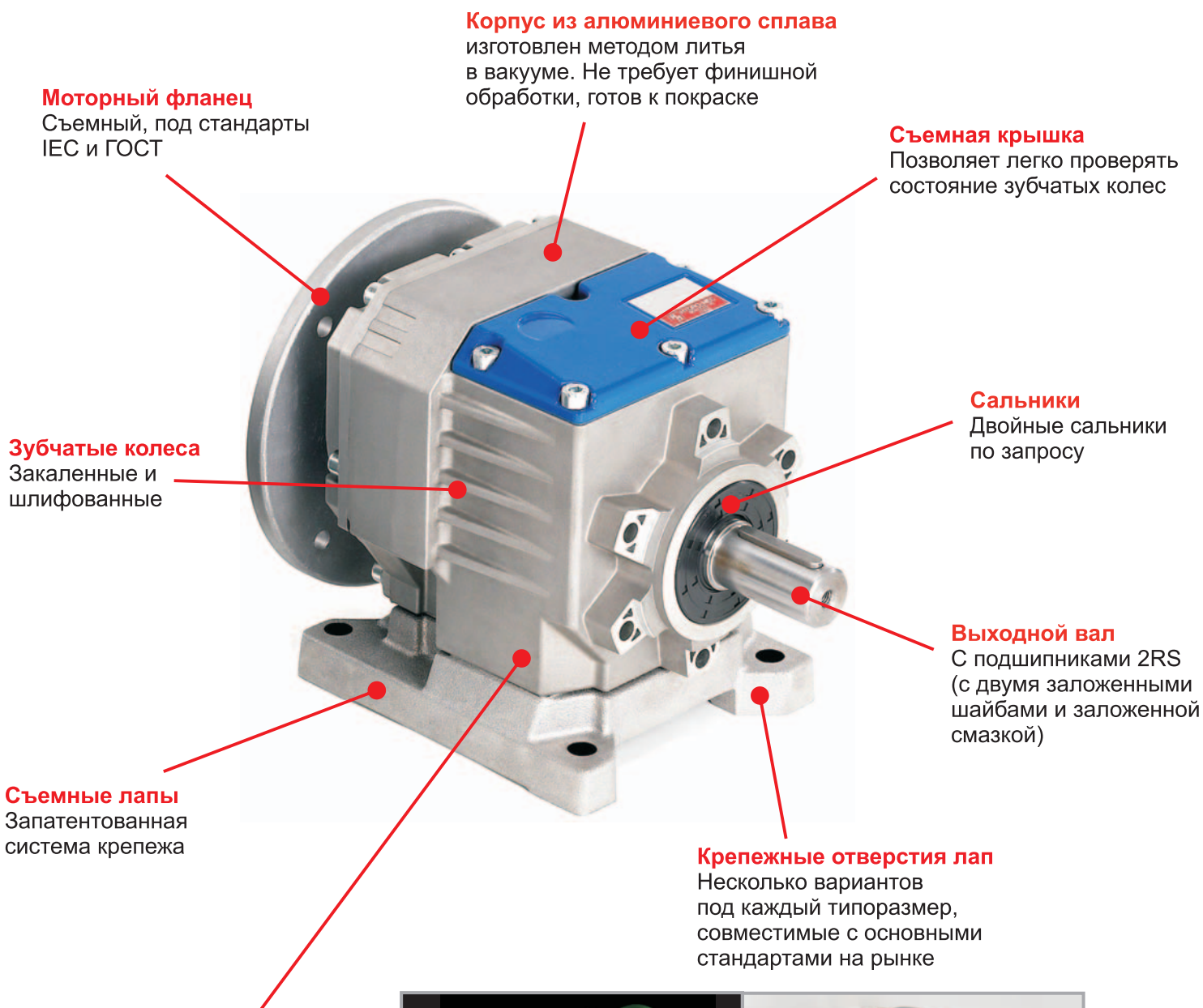

**Цельный корпус из алюминиевого сплава**  
сочетание высокой механической прочности и малого веса. Прецизионная обработка посадочных мест под подшипники и зубчатые колеса

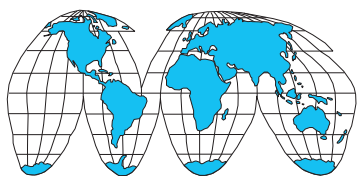
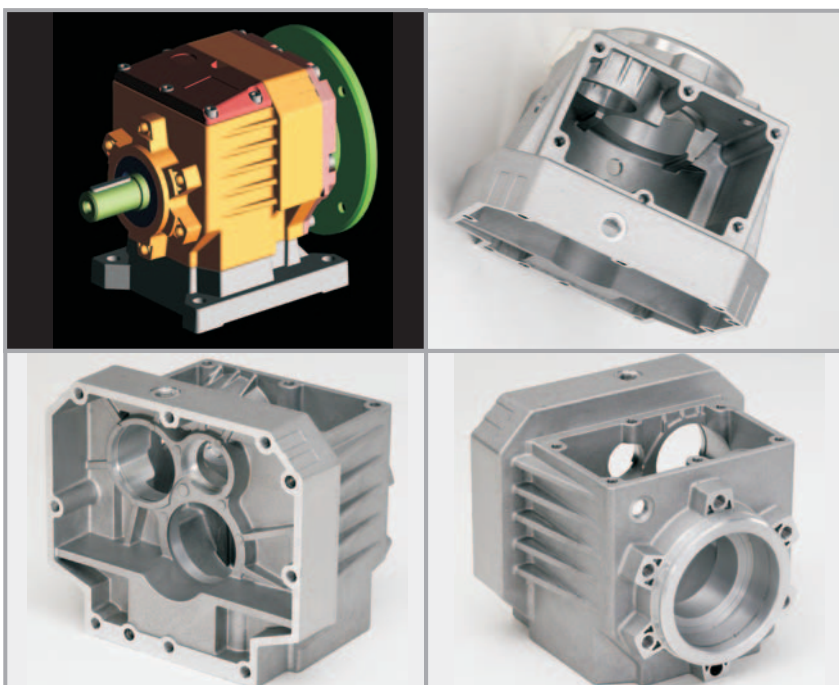

World wide sales network.



# соосные редукторы

100% выходной  
контроль  
качества  
изготовления



**Съемная крышка**  
Позволяет легко проверять  
состояние зубчатых колес

**Моторный фланец**  
Съемный, под  
стандарты  
IEC и ГОСТ

**Сальники**  
Двойные  
сальники  
по запросу

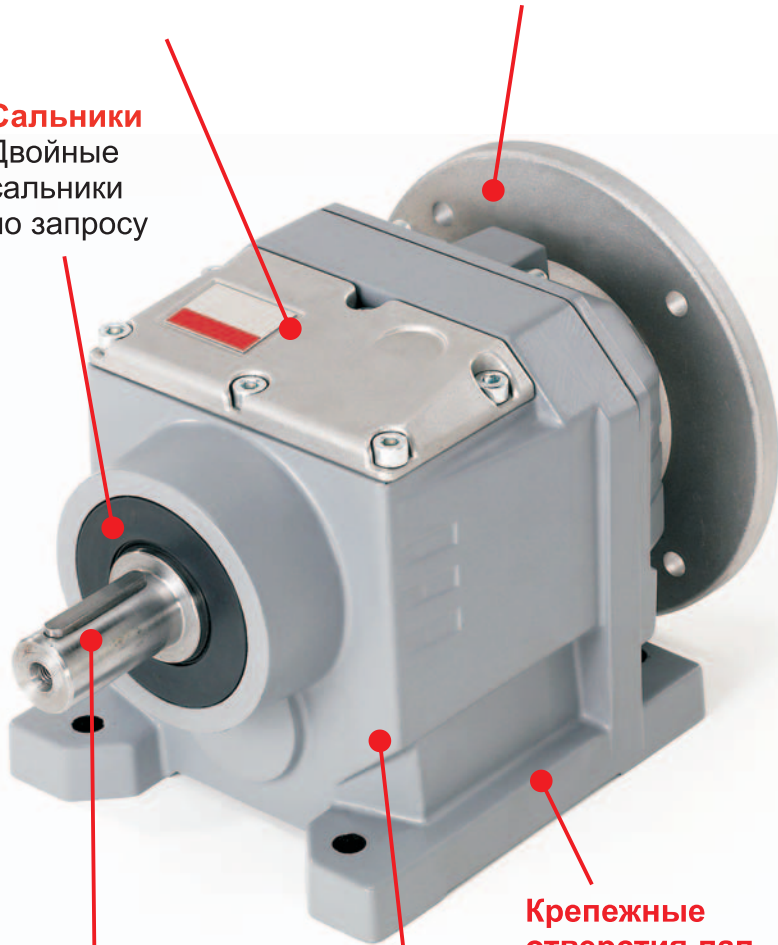

**Выходной вал**  
С подшипниками 2RS  
(с двумя заложеными  
шайбами и заложеной  
смазкой)











**Крепежные  
отверстия лап**  
совместимые  
с основными  
стандартами  
на рынке

**Корпус**  
из серого чугуна

Залиты на весь срок службы  
синтетическим маслом  
для окружающей температуры  
от  $-30^{\circ}$  до  $+80^{\circ}\text{C}$





РЕКОМЕНДАЦИИ ПО ВЫБОРУ SELECTION GUIDE AUSWAHL GUIDE POUR LA SELECTION PARA LA SELECCION	4	
КОД ЗАКАЗА HOW TO ORDER TYPENBEZICHNUNGEN CODIFICATION CODIFICACIUN	10	
СМАЗКА LUBRICATION SCHMIERUNG LUBRIFICATION LUBRICACIUN	13	
РАДИАЛЬНЫЕ И ОСЕВЫЕ НАГРУЗКИ RADIAL AND AXIAL LOADS RADIALE UND AXIALE BELASTUNG CHARGES RADIALES ET AXIALES CARGA RADIAL Y AXIAL	16	
ВЫБОР РЕДУКТОРОВ, РАЗМЕРЫ GEARBOXES SELECTION, DIMENSIONS GETRIEBE OHNE MOTOR- AUSWAHL, ABMESSUNGEN SELECTION REDUCTEURS, DIMENSIONS SELECCIUN REDUCTORES, DIMENSIONES	18	
ВЫБОР МОТОР-РЕДУКТОРОВ GEARMOTORS SELECTION WAHL DES GETRIEBEMOTORS SELECTION DES MOTOREDUCTEURS SELECCIUN MOTO-REDUCTORES	38	
ДОПОЛНИТЕЛЬНЫЕ ПРИНАДЛЕЖНОСТИ ACCESSORIES AND OPTIONALS ZUBEHÖR UND OPTIONEN ACCESSOIRES ET VARIANTES ACCESORIOS Y VARIANTES	60	
УСТАНОВКА И ОБСЛУЖИВАНИЕ INSTALLATION USE AND MAINTENANCE EINBAUVORSCHRIFTEN UND WARTUNG INSTALLATION, UTILISATION ET ENTRETIEN INSTALACIUN, USO Y MANTENIMIENTO	68	
СПИСОК ЗАПЧАСТЕЙ SPARE PARTS LISTS ERSATZTEILLISTE LISTES PIICES DE RECHANGE LISTA DE REPUESTOS	70	
ЭЛЕКТРОДВИГАТЕЛИ ELECTRIC MOTORS ELEKTROMOTOREN MOTEURS ÉLECTRIQUES MOTORES ELÉCTRICOS	72	

Наша компания не несет ответственности за прямые или косвенные убытки, связанные с неправильной эксплуатацией и выбором мотор-редукторов и редукторов.

Our company will not be responsible for any direct or indirect damages caused by a wrong use to the products and or for not observing the catalogue descriptions.

Bei nicht korrektem Einsatz unserer Getriebe oder bei Nichtbeachtung der Katalogvorschriften und daraus resultierender Zerstörung der Getriebe entfällt jegliche Haftung oder Gewährleistung unseres Hauses.

Notre firme n'est pas responsable pour d'éventuels dommages directs ou indirects provenant d'une utilisation impropre des produits et de la non-observation des indications reportées sur le catalogue.

Nuestra empresa no se considerará responsable por daños directos o indirectos que sean debidos al uso indebido de los productos y al incumplimiento de las instrucciones contenidas en el catálogo.

Мы оставляем за собой право на внесение изменений без предварительного уведомления. Также запрещается воспроизведение данного каталога или любой его части без разрешения

We reserve the right to make modifications at any time without prior notice. Furthermore we reserve the prohibition to reproduce or publish pages or whole parts of this catalogue without authorization.

Behält sich das Recht vor, Änderungen ohne vorherige Informationen durchzuführen. Die Veröffentlichung oder Reproduktion des Katalogs ohne Genehmigung ist verboten.

Nous nous réservons le droit d'apporter toutes modifications a nos produits. La reproduction et la publication partielle ou totale de ce catalogue est interdite sans notre autorisation.

Nos reservamos el derecho de modificar el catalogo sin preaviso. Está prohibido reproducir parcial o totalmente este catalogo sin nuestra autorizaciun.



РЕКОМЕНДАЦИИ ПО ВЫБОРУ / SELECTION GUIDE / AUSWAHL  
GUIDE POUR LA SELECTION / GUHA PARA LA SELECCION

RU

UK

Чтобы правильно выбрать редуктор, следуйте, пожалуйста, следующим рекомендациям:

For a proper selection of the required gearbox it is essential to follow the following guide:

Сервис-фактор  
Service factor  
Betriebsfaktor  
Facteur de service  
Factor de servicio

1 Рассчитайте нужный сервис-фактор **fs** по следующей таблице.

Find out the application service factor through the following table.

fs					
Тип нагрузки и количество пусков в час Type of load and starts per hour			Кол-во часов работы в сутки Oper. hours per day		
			3 ч	10 ч	24 ч
Продолжительный или прерывистый режим работы с кол-вом пусков в час Continuous or intermittent appl. with start/hour	≤ 10	Безударная / Uniform	0.8	1	1.25
		Средняя / Moderate	1	1.25	1.5
		Ударная / Heavy	1.25	1.5	1.75
Прерывистый режим работы с кол-вом пусков в час Intermittent application with start/hour	> 10	Безударная / Uniform	1	1.25	1.5
		Средняя / Moderate	1.25	1.5	1.75
		Ударная / Heavy	1.5	1.75	2.15

Для применений с взрывобезопасными двигателями и для реверсивных применений домножьте сервис-фактор на коэффициент 1.15.

N.B. For applications with flameproof motors or instantaneous reversal, multiply the service coefficient by 1.15.

Выбор редуктора  
Gearbox selection  
Getriebeauswahl  
Choix d'un réducteur  
Selección del reductor

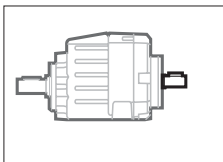

2 Редуктор исполнения R (или B) рассчитывается исходя из требуемой передаваемой мощности  $P_{1r}$  (или из требуемого выходного крутящего момента  $M_{2r}$ ) и скорости на выходном валу  $n_2$  по отношению к входной скорости  $1400 \text{ min}^{-1}$  (или нужного передаточного числа  $i$ ). После того, как редуктор выбран, передаваемая мощность  $P_{1r}$  (указанная в таблице) и входная скорость  $n_1$  должны быть проверены по следующим формулам:

A gearbox version R should be searched for in the selection tables, considering the required  $P_{1r}$  power (or  $M_{2r}$  torque required) and output rpms  $n_2$  referred to  $1400 \text{ min}^{-1}$  (or to reduction ratio). Once the gearbox has been selected upon  $P_{1r}$  power (indicated in the table) and  $n_1$ , it should comply with the following conditions:

$$n_1 = 1400 \text{ min}^{-1}$$

$$P_{1R} \geq P_{1r} \times fs \quad (M_{2R} \geq M_{2r} \times fs)$$

$$n_1 = 2800 \text{ min}^{-1}$$

$$P_{1R} \times 1.6 \geq P_{1r} \times fs \quad (M_{2R} \times 0.8 \geq M_{2r} \times fs)$$

Если необходимо использовать двигатели со скоростью  $2800 \text{ min}^{-1}$  (двухполюсные), укажите это в заказе.

Where 2 pole motors are required, specify when placing order.

$$n_1 = 900 \text{ min}^{-1}$$

$$P_{1R} / 1.5 \geq P_{1r} \times fs \quad (M_{2R} \geq M_{2r} \times fs)$$



2 Poli  
2 Poles  
2 Polig  
2 Poles  
2 Polos

Легенда таблицы выбора:

Following symbols will be found in the selection tables of the gearboxes:

$n_2$ [ $\text{min}^{-1}$ ]	$i$	$P_{1M}$ [kW]	$M_{2M}$ [Nm]	$fs$	$P_{1R}$ [kW]	$M_{2R}$ [Nm]	
398	3.52	1.8	41	1.8	3.3	75	20
320	4.36	1.8	51	1.6	2.8	80	20
252	5.55	1.8	65	1.2	2.2	80	20
220	6.36	1.8	75	1.0	1.8	75	20
191	7.33	1.5	72	1.1	1.7	80	20

$n_2$  [ $\text{min}^{-1}$ ] Выходная скорость ( $n_1 = 1400 \text{ min}^{-1}$ )  
 $i$  — передаточное число  
 $P_{1M}$  [kW] Мощность двигателя ( $n_1 = 1400 \text{ min}^{-1}$ )  
 $P_{1R}$  [kW] Передаваемая мощность при  $fs=1$  ( $n_1 = 1400 \text{ min}^{-1}$ )  
 $M_{2M}$  [Nm] Крутящий момент на выходе относительно  $P_{1M}$  ( $n_1 = 1400 \text{ min}^{-1}$ )  
 $M_{2R}$  [Nm] Передаваемый момент относительно  $P_{1R}$  ( $n_1 = 1400 \text{ min}^{-1}$ )  
 $fs$  — сервис-фактор (относительно  $P_{1M}$ )

$n_2$  [ $\text{min}^{-1}$ ] output speed ( $n_1 = 1400 \text{ min}^{-1}$ )  
 $i$  — reduction ratio  
 $P_{1M}$  [kW] motor input power ( $n_1 = 1400 \text{ min}^{-1}$ )  
 $P_{1R}$  [kW] transmitted power at input gearbox with  $fs=1$  ( $n_1 = 1400 \text{ min}^{-1}$ )  
 $M_{2M}$  [Nm] output torque referred to  $P_{1M}$  ( $n_1 = 1400 \text{ min}^{-1}$ )  
 $M_{2R}$  [Nm] output torque referred to  $P_{1R}$  ( $n_1 = 1400 \text{ min}^{-1}$ )  
 $fs$  — service factor (referred to  $P_{1M}$ )



D

F

E

Für eine exakte Auswahl der benötigten Getriebe werden folgende Angaben benötigt:

Pour une sélection correcte du réducteur ou du moteur réducteur il est important de respecter les indications suivantes:

Para una correcta selección del reductor o moto-reductor es importante respetar las siguientes indicaciones:

Anhand der beigefügten Tabelle kann der Betriebsfaktor bestimmt werden:

Déterminer au moyen du tableau suivant le facteur de service **fs** correspondant à l'application.

Determinar a través de la tabla siguiente el factor de servicio **fs** correspondiente a la aplicación.

fs					
Belastungsart und schaltungen/Stunde Type de charge et type de fonctionnement par heure Tipo de carga y arranques/hora		Betriebsstunden bestiften pro tag Opérations heure par hour Horas de trabajo por día			
		3 h	10 h	24 h	
Daueranwendung oder unterbrochene Anwendung mit Anzahl Starts/Stunde Service continu ou intermittent avec démarrage/heure Aplicación continua o intermitente con número de arranques/hora	≤ 10	Gleichmäßige Belastung Normal / Uniforme	0.8	1	1.25
		Mittlere Belastung Légère / Moderado	1	1.25	1.5
		Schwere Belastung Forte / Fuerte	1.25	1.5	1.75
Unterbrochene Anwendung mit Anzahl Starts/Stunde Service intermittent avec démarrage/heure Aplicación intermitente con número de arranques/hora	> 10	Gleichmäßige Belastung Normal / Uniforme	1	1.25	1.5
		Mittlere Belastung Légère / Moderado	1.25	1.5	1.75
		Schwere Belastung Forte / Fuerte	1.5	1.75	2.15

Achtung: Bei Einsatz der Getriebe mit Verbrennungsmotoren bzw. anderen stark lastschwankenden Antrieben ist der Betriebsfaktor mit 1.15 zu multiplizieren.

N.B. Pour des actionnements avec moteur à explosion ou pour un fonctionnement alternatif instantané, multiplier la valeur du coefficient de service par 1.15

Atención: Para accionamientos con motor de explosión o para funcionamiento con cargas alternas puntuales, multiplicar el valor del coeficiente de servicio por 1.15.

Auswahl eines Getriebetyps R (oder "B") aus den Auswahltabellen unter Berücksichtigung der Leistung bzw. des Drehmomentes, der Eintriebsdrehzahl 1400 1/min der Untersetzung i und des daraus resultierenden Abtriebsdrehmomentes. Sollte das Getriebe von der Leistung und der Eintriebsdrehzahl (1400 1/min) nicht nach der nebenstehenden Tabelle ausgewählt werden können, so ist folgendes zu beachten:

Un réducteur dans la configuration R (ou B) devra être recherché dans les tableaux de sélection réducteurs sur la base de la puissance demandée  $P_{1r}$  (ou du couple maximal  $M_{2r}$ ) et une vitesse de sortie  $n_2$  se référant à 1400 min (ou au rapport de transmission i). Le réducteur sélectionné sur la base de la puissance  $P_1$  (indiquée sur le tableau) et de  $n_1$  devra satisfaire les conditions suivantes:

Un reductor en la configuración R (o B) tendrá que buscarse en las tablas para la selección de los reductores en función de la potencia requerida  $P_{1r}$  (o del par máximo  $M_{2r}$ ) y de las revoluciones salida  $n_2$  referidas a 1400 min (o a la relación de transmisión i). El reductor elegido en función de la potencia  $P_1$  (indicada en la tabla) y a  $n_1$  deberá satisfacer las condiciones siguientes:

$$n_1 = 1400 \text{ min}^{-1}$$

$$P_{1R} \geq P_{1r} \times fs \quad (M_{2R} \geq M_{2r} \times fs)$$

$$n_1 = 2800 \text{ min}^{-1}$$

$$P_{1R} \times 1.6 \geq P_{1r} \times fs \quad (M_{2R} \times 0.8 \geq M_{2r} \times fs)$$

Beim Anbau von zweipoligen Motoren bitte immer bei der Bestellung angeben.

Pour le montage de moteurs à 2800 min, toujours spécifier cette caractéristique en phase de commande.

Para el montaje con motores de 2800 min, especificar siempre esta característica al efectuar el pedido.

$$n_1 = 900 \text{ min}^{-1}$$

$$P_{1R} / 1.5 \geq P_{1r} \times fs \quad (M_{2R} \geq M_{2r} \times fs)$$

Folgende Zeichen sind in der Auswahltabelle für Getriebe zu finden

Aux tableaux de sélection des réducteurs est associée la symbolologie suivante:

A las tablas para la selección de los reductores se ha asociado la simbología siguiente:

$n_2$	[ $\text{min}^{-1}$ ]	Abtriebsdrehzahl ( $n_1 = 1400 \text{ 1/min}$ )
i	—	Lieferbare Untersetzungen
$P_{1M}$	[kW]	Motoreingangsleistung ( $n_1 = 1400 \text{ min}^{-1}$ )
$P_{1R}$	[kW]	Durchtriebsleistung am Getriebe eingang $fs=1$ ( $n_1 = 1400 \text{ min}^{-1}$ )
$M_{2M}$	[Nm]	Ausgangsdrehmoment bezogen auf $P_{1M}$ ( $n_1 = 1400 \text{ min}^{-1}$ )
$M_{2R}$	[Nm]	Ausgangsdrehmoment bezogen auf $P_{1R}$ ( $n_1 = 1400 \text{ min}^{-1}$ )
fs	—	Betriebsfaktor (bezogen auf $P_{1M}$ )

$n_2$	[ $\text{min}^{-1}$ ]	vitesse de sortie ( $n_1 = 1400 \text{ min}^{-1}$ )
i	—	rapport de réduction
$P_{1M}$	[kW]	puissance du moteur ( $n_1 = 1400 \text{ min}^{-1}$ )
$P_{1R}$	[kW]	puissance du réducteur en entrée $fs=1$ ( $n_1 = 1400 \text{ min}^{-1}$ )
$M_{2M}$	[Nm]	couple de sortie rapportée à $P_{1M}$ ( $n_1 = 1400 \text{ min}^{-1}$ )
$M_{2R}$	[Nm]	couple de sortie rapportée à $P_{1R}$ ( $n_1 = 1400 \text{ min}^{-1}$ )
fs	—	facteur de service (rapportée à $P_{1M}$ )

$n_2$	[ $\text{min}^{-1}$ ]	revoluciones de salida ( $n_1 = 1400 \text{ min}^{-1}$ )
i	—	relación de reducción
$P_{1M}$	[kW]	potencia motor ( $n_1 = 1400 \text{ min}^{-1}$ )
$P_{1R}$	[kW]	potencia transmitida en la entrada $fs=1$ ( $n_1 = 1400 \text{ min}^{-1}$ )
$M_{2M}$	[Nm]	par de salida referida a $P_{1M}$ ( $n_1 = 1400 \text{ min}^{-1}$ )
$M_{2R}$	[Nm]	par de salida referida a $P_{1R}$ ( $n_1 = 1400 \text{ min}^{-1}$ )
fs	—	factor de servicio (referida a $P_{1M}$ )



РЕКОМЕНДАЦИИ ПО ВЫБОРУ / SELECTION GUIDE / AUSWAHL  
GUIDE POUR LA SELECTION / GUHA PARA LA SELECCION

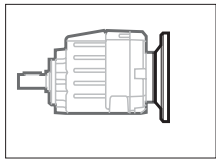

**3** Таблицы также необходимы для выбора редукторов версии P (с фланцем двигателя стандарта IEC B5 или B14). В этом случае необходимо проверить соответствие размеров двигателя (63, 71, и т.д.). Совместимые типоразмеры двигателей отмечены в таблице темным цветом.

Selection tables can be used also for mounting version P (prearranged for motor attachment throughout IEC flange B5 or B14). In this case, besides carrying out all previous cheques, it is also important to verify the suitability of the required motorsizes (63, 71, etc.) in the shaded columns. Associated symbols are the following:

Легенда:

B5					B14					RD	
B	C	D	E	F	O	P	Q	R	T		U
63	71	80	90	100 112	56	63	71	80	90	100 112	
B	B						B-C	C			96
B	B						B-C	C			96
B	B						B-C	C			96
B	B						B-C	C			96
B	B						B-C	C			96

63... — типоразмер двигателя (IEC)  
B5 — моторный фланец B5  
B14 — моторный фланец B14  
— стыкуется  
B — монтируется с проставкой  
C — положение отверстий в моторном фланце редуктора  
RD — динамический КПД

63... — suitable motor sizes (IEC)  
B5 — B5 motorflange  
B14 — B14 motorflange  
— available motor adaptors  
B — assembling by means of reduction bushes  
C — motor flange/terminal box position  
RD — dynamic efficiency

**Выбор мотор-редукторов**  
**Selection of a motorized gearbox**  
**Auswahl eines Getriebes mit Motor**  
**Choix d'un moto-réducteur**  
**Selección del moto-reductor**

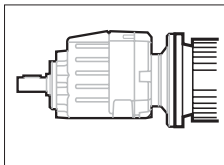

**4** Мотор-редукторы (версия M) могут быть легко выбраны с помощью соответствующих таблиц. Зная мощность P<sub>1</sub>, и соответствующую ей выходную скорость, редуктор должен быть выбран из таблицы с сервис-фактором больше или равным расчетному. В дополнение к 4-х полюсным моторам (1400 min<sup>-1</sup>) можно также выбрать 2-х полюсные (2800 min<sup>-1</sup>) и 6-полюсные (900 min<sup>-1</sup>).

Motorised gearboxes (version M) can be easily selected throughout the appropriate selection tables. Knowing P<sub>1</sub> value, in corresponding to the required output speed, the gearbox should be selected having a service factor equal or higher than the one shown in point 1. In addition to 4 pole motors (1400 min<sup>-1</sup>) it is also possible to select 2 pole (2800 min<sup>-1</sup>) and 6 pole (900 min<sup>-1</sup>) motors.

P <sub>1M</sub> = 0.75 kW						1400 min <sup>-1</sup> (80B4) - 900 min <sup>-1</sup> (90S6)			
n <sub>2</sub> [min <sup>-1</sup> ]	M <sub>2</sub> [Nm]	i	fs		511	IEC			
						B5	B14		
133	53	10.50	1.5	24/28	511	80B4	71 <sup>B</sup> -80-90-100/112	80-90-100/112	
139	49	10.06	3.0	24/25	402A	80B4	63 <sup>B</sup> -71-80-90	71 <sup>C</sup> -80 <sup>C</sup> -90-100/112	●
139	49	10.04	3.0	24/25	402C	80B4	63 <sup>B</sup> -71-80-90	71 <sup>C</sup> -80 <sup>C</sup> -90-100/112	●
142	48	9.85	2.0	20	302A	80B4	63 <sup>B</sup> -71-80-90	71 <sup>C</sup> -80 <sup>C</sup> -90	●
165	42	5.45	1.2	20	302A	90S6	63 <sup>B</sup> -71-80-90	71 <sup>C</sup> -80 <sup>C</sup> -90	●

Легенда:

Following symbols are associated to the selection tables of the geared motors:

P<sub>1M</sub> [kW] Входная мощность  
n<sub>2</sub> [min<sup>-1</sup>] Выходная скорость  
M<sub>2</sub> [Nm] Крутящий момент на выходе  
i — передаточное число  
fs — сервис-фактор  
B5 — моторный фланец B5  
B14 — моторный фланец B14  
B) — монтируются с проставкой  
C) — положение отверстий в моторном фланце редуктора  
возможные моторные фланцы

P<sub>1M</sub> [kW] input power  
n<sub>2</sub> [min<sup>-1</sup>] output speed  
M<sub>2</sub> [Nm] transmitted output torque  
i — reduction ratio  
fs — service factor  
B5 — B5 motorflange  
B14 — B14 motorflange  
B) — coupling by means of reduction bushing  
C) — motor flange/terminal box position  
suitable motorflanges IEC







D

F

E

Die Auswahltabellen werden auch für die Montage der P- Version (vorbereitet für Motorflansche nach IEC - B5 bzw. B14) verwendet. In diesem Fall sind die anbaubaren Motorgrößen (BG 63, 71 usw.) aus der unterlegten Tabelle zu entnehmen.



Folgende Symbole werden verwendet:

- 63,... — Mögliche Motorgrößen nach IEC
- B5 — Motorflansche B5
- B14 — Motorflansche B14
- Mögliche Motoradapter
- B — Zusammenbau unter Verwendung der Reduzierhülzen 
- C — Bohrungsposition am Motorflansch/-sockel 
- RD — Dynamischer Wirkungsgrad

Les tableaux pour la sélection des réducteurs peuvent aussi être utilisés pour les réducteurs dans la configuration P (prédisposés pour montage moteur IEC B5 ou B14). En plus des vérifications précédentes, il est nécessaire de contrôler dans les colonnes traitées l'application de la taille (63, 71, etc.) du moteur souhaité. La symbolique utilisée est la suivante:

- 63,... — taille moteur (IEC) applicables
- B5 — prédisposition brides B5
- B14 — prédisposition brides B14
- tailles moteurs pouvant être accouplées
- B — montage avec douille de réduction 
- C — position trous bride/barrette a bornes moteur 
- RD — rendement dynamique





Las tablas para la selección de los reductores pueden también utilizarse para los reductores en la configuración P (predispuestos para el montaje con el motor IEC B5 y B14). Además de los controles anteriormente ilustrados, es necesario controlar, en las columnas reticuladas, la aplicación del tamaño (63, 71, etc.) del motor deseado. La simbología adicional asociada es la siguiente:

- 63,... — tamaño motor (IEC) aplicables
- B5 — predisposición bridas B5
- B14 — predisposición bridas B14
- tamaño motor acoplable
- B — montaje con casquillo de reducción 
- C — posición agujeros brida / base motor 
- RD — rendimiento dinámico

Getriebe mit Motoren (version M) werden einfach durch die Auswahltabellen ausgesucht. Ist die Leistung ( $P_1$ ) und die Abtriebsdrehzahl bekannt so sollte das ausgesuchte Getriebe einen Betriebsfaktor  $>1$  haben. Anstelle von 4-polige Motoren können auch 6- polige Motoren verwendet werden.- Drehzahlen beachten.

Les moto-réducteurs (configuration M) peuvent être sélectionnés aisément au moyen des tableaux de sélection moto-réducteurs. En connaissant  $P_1$ , en correspondance de la vitesse de sortie  $n_2$  souhaité, on choisira le moto-réducteur dont le facteur de service  $f_s$  soit égal ou supérieur a celui défini au point 1. En plus des motorisations avec moteurs a 4 pôles ( $1400 \text{ min}^{-1}$ ) il est possible de sélectionner (la ou disponible) des moteurs a 6 pôles ( $900 \text{ min}^{-1}$ )



Los moto-reductores (configuración M) pueden seleccionarse fácilmente a través de las tablas de los moto-reductores. Conociendo  $P_1$ , en correspondencia del número de revoluciones en salida  $n_2$  deseado, se elegirá el moto-reductor cuyo factor de servicio  $f_s$  sea igual o mayor al definido en el punto 1. Además de las motorizaciones con motores de 4 polos ( $1400 \text{ min}^{-1}$ ) es posible seleccionar (si está disponible) motores de 6 polos ( $900 \text{ min}^{-1}$ ).



P <sub>1M</sub> = 0.75 kW					1400 min <sup>-1</sup> (80B4) - 900 min <sup>-1</sup> (90S6)					
n <sub>2</sub> [min <sup>-1</sup> ]	M <sub>2</sub> [Nm]	i	f <sub>s</sub>							
							B5	B14		
	133	53	10.50	1.5	24/28	511	80B4	71 <sup>B)</sup> -80-90-100/112	80-90-100/112	
139	139	49	10.06	3.0	24/25	402A	80B4	63 <sup>B)</sup> -71-80-90	71 <sup>C)</sup> -80 <sup>C)</sup> -90-100/112	●
	139	49	10.04	3.0	24/25		402C	80B4	71 <sup>C)</sup> -80 <sup>C)</sup> -90-100/112	●
	142	48	9.85	2.0	20	302A	80B4	63 <sup>B)</sup> -71-80-90	71 <sup>C)</sup> -80 <sup>C)</sup> -90	●
	165	42	5.45	1.2	20	302A	90S6	63 <sup>B)</sup> -71-80-90	71 <sup>C)</sup> -80 <sup>C)</sup> -90	●



Symbole der Auswahltabellen für Getriebe mit Motor

Aux tableaux de sélection des moto-réducteurs est associée la symbolique suivante:

A las tablas para la selección de los moto-reductores se ha asociado la simbología siguiente:

- P<sub>1M</sub> [kW] Leistung Motor
- n<sub>2</sub> [min<sup>-1</sup>] Abtriebsdrehzahl
- M<sub>2</sub> [Nm] Abtriebsdrehmoment
- i — Lieferbare Untersetzungen
- f<sub>s</sub> — Betriebsfaktor
- B5 — Motorflansche B5
- B14 — Motorflansche B14
- B) — Reduzierhülzen 
- C) — Bohrungsposition am Motorflansch/-sockel 
-  Lieferbare Motorflansche nach IEC

- P<sub>1M</sub> [kW] puissance en entrée
- n<sub>2</sub> [min<sup>-1</sup>] vitesse de sortie
- M<sub>2</sub> [Nm] couple transmis en sortie
- i — rapport de réduction
- f<sub>s</sub> — facteur de service
- B5 — prédisposition brides B5
- B14 — prédisposition brides B14
- B) — Montage avec douille de réduction 
- C) — position trous bride/barrette a bornes moteur 
-  bridas acoplamiento motor IEC disponibles

- P<sub>1M</sub> [kW] potencia de entrada
- n<sub>2</sub> [min<sup>-1</sup>] revoluciones de salida
- M<sub>2</sub> [Nm] Par transmitido de salida
- i — relación de reducción
- f<sub>s</sub> — factor de servicio
- B5 — predisposición bridas B5
- B14 — predisposición bridas B14
- B) — montaje con casquillo de reducción 
- C) — posición agujeros brida / base motor 
-  bridas acoplamiento motor IEC disponibles



RU

UK

Для более быстрого выбора мотор-редуктора (близкого к сервис-фактору 1) может быть использована таблица выбора редукторов.  
В этой таблице указаны только 4-х полюсные моторы ( $1400 \text{ min}^{-1}$ ).

An easier selection of the motorized gearbox (closer as possible to sf 1) can be effected throughout gear selection table (Point 2). In fact only 4 pole motors ( $1400 \text{ min}^{-1}$ ) are listed here.

**Стыковка с вариатором**  
**Gearbox coupled to a speed variator**  
**Getriebe mit Regelgetriebe kombiniert**  
**Réducteur avec variateur de vitesse**  
**Reductor con variador de velocidad**

**5** При стыковке редуктора через механический или гидравлический вариатор, обращайте внимание на наличие низких рабочих скоростей, т.к. в этом случае момент на выходе  $M_2$  может легко превысить номинальное значение. Это особенно важно при больших передаточных числах.

Where a hydraulic or mechanic variator is coupled to a gearbox, it is necessary to take into consideration the fact that in the presence of low output speed, decreasing the input speed,  $M_2$  torques can easily exceed their nominal values. In high reduction ratios this effect should be taken even in more consideration.

**Стыковка с мотором со встроенным тормозом**  
**Gearbox equipped with a brake motor**  
**Getriebebremmotor**  
**Réducteur avec moteur frein**

**6** При стыковке с моторами со встроенным тормозом обращайте внимание на моменты инерции вращающихся масс. Лучше выбирать мотор-редукторы с сервис-фактором  $f_s \geq 1$ .

For selection with brake motors, having considerable mass inertia values, it is advisable to select gearboxes with sf higher or equal to 1.

**Применения, не указанные в каталоге**  
**Selections not listed in the catalogue**  
**Auswahl von Nichtkatalog-Getrieben**  
**Sélection hors catalogue**  
**Selecciyñ fuera de catálogo**

**7** При стыковке редукторов с более мощными двигателями, чем указанные в каталоге, мы не гарантируем корректной работы мотор-редуктора.

In those cases where higher powers than the ones given in this catalogue have to be used, our factory cannot guarantee the proper operation of the gearbox.

**Важно!**  
**Notes**  
**Anmerkungen**  
**Note**  
**Notas**

**8** В следующих случаях желательно согласовать выбор с нашим сервис-центром:

- Применения, где отказ мотор-редуктора критичен (простой оборудования и т.д.).
- Применения с высокими инерционными массами.
- Подъемно-транспортное оборудование.
- Высокие нагрузки на корпус редуктора.
- Окружающая температура ниже  $5^\circ\text{C}$  или выше  $40^\circ\text{C}$ .
- Высокоагрессивные химические среды.
- Солевая среда.
- Применения, не указанные в таблице выбора.
- Радиоактивная среда.
- Давление выше атмосферного.

- Избегайте применений с полным или частичным погружением редуктора.

Take in due consideration following applications by contacting our technical Service.

- Dangerous applications in case of gearbox breakage.
- Particularly high inertia applications
- Lifting devices.
- High dynamic stress on gearbox housing.
- Particular environment conditions with temperatures lower than  $5^\circ\text{C}$  or higher than  $40^\circ\text{C}$ .
- Highly chemical aggressive environment.
- Salty environment.
- Applications not considered in the catalogue.
- Radioactive environment.
- Pressure different to atmospheric.
- Avoid those applications where total or partial immersion of the gearbox is required.



D

F

E

Eine weitere Auswahl von Getriebemotoren kann durch Selektion der Verzahnungen getroffen werden. Dadurch kann der Betriebsfaktor näher an 1 gelegt werden. Es sind nur 4-polige Motoren (1400 1/min) aufgeführt.

Une sélection simplifiée du moto-réducteur sur la base d'un unique facteur de service (le plus proche de 1) peut être effectuée au moyen des tableaux de sélection réducteurs (point 2). Dans ce cas, sont reportés uniquement les moto-réducteurs. Avec moteurs à 4 pôles (1400 min<sup>-1</sup>).

Una selección simplificada del moto-reductor en base de un único factor de servicio (el más próximo a 1) puede efectuarse a través de las tablas para la selección del reductor (punto 2). En este caso se incluyen exclusivamente los moto-reductores con motores de 4 polos (1400 min<sup>-1</sup>).

Beim Anbau eines mechanischen oder hydraulischen Regelgetriebes muss darauf geachtet werden, daß sich bei niederen Eintriebsdrehzahlen in das Getriebe die Drehmomente deutlich erhöhen. Besonders bei höheren Untersetzungen muss dies gesondert beachtet werden.

Au cas où on assemblerait au réducteur un variateur hydraulique ou mécanique, il est nécessaire de considérer que lorsque la vitesse d'entrée diminue, les couples M<sub>2</sub> peuvent dépasser même considérablement la valeur nominale cet effet doit être encore plus tenu en considération dans les rapports élevés.

Si al reductor se le acopla un variador hidráulico o mecánico, es necesario considerar que a bajas revoluciones, al disminuir la velocidad de entrada, los pares M<sub>2</sub> podrán superar, el máximo del valor nominal. Este efecto debe tenerse todavía en cuenta en las relaciones de reducción elevadas.

Bei der Auswahl der Getriebe mit Bremsmotor ist es wichtig, die Massenträgheit des Motors zu beachten. Die Getriebe immer mit einem Betriebsfaktor ≥ 1 auszuwählen.

Dans la sélection avec moteurs freins, puisque l'effet inertiel des masses peut être considérable, il est opportun de choisir des réducteurs avec fs ≥ 1.

En la selección con motores freno, pudiendo ser considerable el efecto inercial de las masas, es conveniente elegir reductores con fs ≥ 1.

Werden die Getriebe mit größeren Leistungen als im Katalog angegeben belastet, kann Hydromec keine Gewährleistung für sicheren Betrieb übernehmen.

Au cas où on appliquerait des puissances supérieures à celles indiquées sur le catalogue, notre société ne peut pas garantir le fonctionnement correct du groupe.

Si se aplican potencias superiores a las indicadas en el catálogo, nuestra empresa no puede garantizar el correcto funcionamiento del grupo.

Bei folgenden Einsatzfällen sollte mit unserer technischen Abteilung Rücksprache gehalten werden:

- Mechanische Beanspruchung, die zum Gehäusbruch führen kann.
- Einsatzfälle mit höheren Eintriebsleistungen als angegeben.
- Hubantriebe.
- Höchste dynamische Belastungen des Gehäuses.
- Umgebungstemperaturen höher + 50°C und kleiner + 5°C.
- Chemisch aggressive Umgebung.
- Salzhaltige Umgebungsluft.
- Umgebungsbedingungen und Einsatzfälle die nicht im Katalog aufgeführt sind.
- Radioaktive Umgebungsbedingungen
- Anderer Luftdruck als der Atmosphärendruck.
- Alle ungewöhnlichen Einsatzbedingungen, von denen unsere Getriebe teilweise oder im Ganzen betroffen sind.

Il faut considérer et évaluer attentivement les applications suivantes par la consultation de notre Service Technique:

- Utilisation pour des services dangereux pour l'homme en cas de casse du réducteur.
- Applications avec des inerties particulièrement élevées.
- Utilisation comme organe de lavage.
- Applications avec des sollicitations dynamiques élevées sur la caisse du réducteur.
- Utilisation avec une température ambiante inférieure à 5°C ou supérieure à 40°C.
- Utilisation en ambiance avec présence d'agents chimiques.
- Utilisation en ambiance saumâtre.
- Positions de montage non prévues dans le catalogue.
- Utilisation en ambiance radioactive.
- Utilisation avec une pression différente que celle atmosphérique.
- Éviter les applications avec une immersion, même partielle, du réducteur.

Las siguientes aplicaciones deben considerarse en modo adecuado y evaluarse atentamente consultando nuestro Servicio Técnico

- Utilización en servicios que podrán resultar peligrosos para la persona en caso de rotura del reductor.
- Aplicaciones con inercias particularmente elevadas.
- Utilización como órgano de elevación.
- Aplicaciones con elevadas exigencias dinámicas en la carcasa del reductor.
- Utilización en ambiente con temperatura inferior a 5°C o superior a 40°C.
- Utilización en ambiente con presencia de agentes químicos.
- Utilización en ambiente salobre.
- Posiciones de montaje no previstas en el catálogo.
- Utilización en ambiente radioactivo.
- Utilización en ambiente con presión distinta a la atmosférica.
- Evitar aplicaciones en las que se prevía la inmersión, incluso parcial, del reductor.

Тип - Type - Tur - Turpes - Tipo

Габарит  
Size  
Größe  
Taille  
Tamaco

Тип крепления - Mounting - Montage - Fixation - Tipo de montaje

**P**

**402..**

**S2**

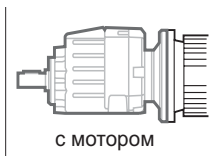

**M**

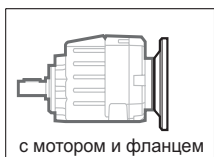

**P**

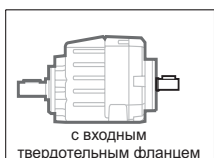

**R**



**B**

Алюминий  
Aluminium  
Aluminium  
Aluminium  
Aluminio



Чугун  
Cast iron  
Grauguss  
Fonte  
Fundicion



2  
Ступени  
Stages  
Stufen  
Trains  
Etapas

**202A** M<sub>2R</sub> = 70 Nm

**302A** M<sub>2R</sub> = 120 Nm

**402A** M<sub>2R</sub> = 150 Nm

**452A** M<sub>2R</sub> = 300 Nm

**502A** M<sub>2R</sub> = 320 Nm

**602A** M<sub>2R</sub> = 460 Nm

**402C** M<sub>2R</sub> = 195 Nm

**602C** M<sub>2R</sub> = 460 Nm

3  
Ступени  
Stages  
Stufen  
Trains  
Etapas

**403A** M<sub>2R</sub> = 150 Nm

**503A** M<sub>2R</sub> = 320 Nm

**603A** M<sub>2R</sub> = 460 Nm

**403C** M<sub>2R</sub> = 195 Nm

**603C** M<sub>2R</sub> = 460 Nm

Алюминий  
Aluminium  
Aluminium  
Aluminium  
Aluminio

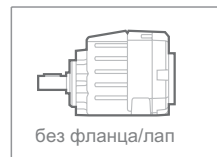

**-N**

Чугун  
Cast iron  
Grauguss  
Fonte  
Fundicion

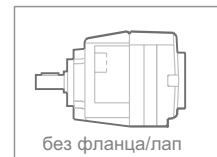

**-N**

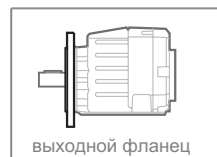

**-F**

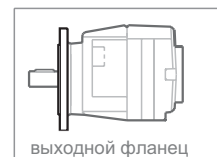

**-F**

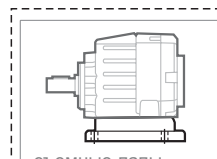

**B..**

**S..**

**M..**

**L..**

Код лап вы найдете  
в таблице  
You see feet code in the chart  
of the dimensions

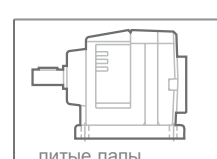

**SP**

Market reference	Feet Code:	G	H	R	L	S	H 1
302/3	B 3	18	110	160	130	190	1 <sup>f</sup>
30 / 35	B 4	20	130	180	149.5	216	
47 - 57	S 4	30	115	135	165	170	
06	L 6	19	125	160	106	106	2 <sup>c</sup>
2202/3	E 2	13	100	135	192		
52/3	M 2	30	110	135+150			
142	P 4	35	142	130			
4100-05G	J 3	25	100				



Передаточное число  
Ratio  
Übersetzung  
Reduction  
Relacirn

Выходной вал  
Output shaft  
Abtriebswelle  
Arbre lent  
Eje de salida

Выходной фланец  
Output flange  
Ausgangsflansch  
Bride de sortie  
Brida de salida

Типоразмер фланца  
Motor size  
Motor Größe  
Grandeur moteur  
Tamaco motor

Типоразмер двигателя  
Motor version  
Motor Bauform  
Forme constr. moteur  
Forma constr. motor

Позиция клеммной коробки  
Terminal box position  
Klemmkastenlage  
Pos. boîte a bornes

Монтажная позиция  
Mounting position  
Einbaulage  
Position de montage  
Position de montage

**3.10**

**V**

**2**

**C**

**B5**

**A**

**B3**

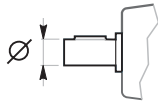

→ STANDARD

202A 302A

- S → ∅ 14
- B → ∅ 16
- C → ∅ 19
- D → ∅ 20
- E → ∅ 24
- V → ∅ 25
- G → ∅ 28

402A 403A  
402C 403C

- S → ∅ 14
- B → ∅ 16
- C → ∅ 19
- D → ∅ 20
- E → ∅ 24
- V → ∅ 25

452A 502A 503A

- E → ∅ 24
- V → ∅ 25
- G → ∅ 28
- H → ∅ 30
- I → ∅ 35

602A 603A  
602C 603C

- H → ∅ 30
- I → ∅ 35
- L → ∅ 38
- M → ∅ 40

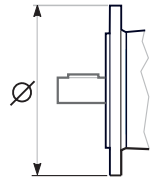

**N** Без фланца  
Without flange

202A 302A  
402A 403A  
402C 403C

- 1 → ∅ 120
- 2 → ∅ 140
- 3 → ∅ 160
- 4 → ∅ 200

452A 502A 503A

- 3 → ∅ 160
- 4 → ∅ 200
- 5 → ∅ 250

602A 603A  
602C 603C

- 3 → ∅ 160
- 4 → ∅ 200
- 5 → ∅ 250

Flangia Standard  
Standard Flange

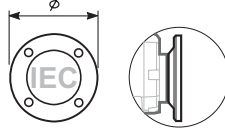

- | B5                         | B14                        |
|----------------------------|----------------------------|
| <b>A=56</b><br>(ш120)      | <b>O=56</b><br>(ш80)       |
| <b>B=63</b><br>(ш140)      | <b>P=63</b><br>(ш90)       |
| <b>C=71</b><br>(ш160)      | <b>Q=71</b><br>(ш105)      |
| <b>D=80</b><br>(ш200)      | <b>R=80</b><br>(ш120)      |
| <b>E=90</b><br>(ш200)      | <b>T=90</b><br>(ш140)      |
| <b>F=100-112</b><br>(ш250) | <b>U=100-112</b><br>(ш160) |
|                            | <b>V=132</b><br>(ш200)     |

Flangia ridotta  
Reduced Flange

302A 503A 402A 402C 403C  
603A 603C

- 1 → ш19 (71B5)
- 2 → ш24 (80B5)
- 3 → ш28 (90B5)

202A 403A 452A 502A  
602A 602C

- 5 → ш11 (56B5)
- 6 → ш14 (63B5)
- 7 → ш19 (71B5)
- 2 → ш24 (80B5)
- 3 → ш28 (90B5)

Типо R  
Type R

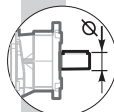

302A 402A 402C 403C  
503A 603A 603C

- STANDARD
- 2 → ш19
  - 1 → ш14
  - 3 → ш24

Senza flangia  
Without flange

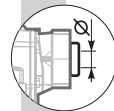

302A 402A 402C 403C  
503A 603A 603C

- 1 → ш14 (71B5)
- 2 → ш19 (80B5)
- 3 → ш24 (90B5)
- 2 → ш19 (80B5)
- 3 → ш24 (90B5)
- 4 → ш28 (100B5)

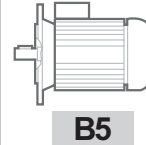

**B5**

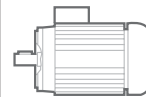

**B14**

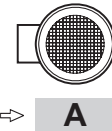

→ **A**



→ **B**

СТАНДАРТ

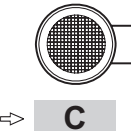

→ **C**



→ **D**

См. таблицы  
See tables  
Siehe Tabelle  
Voir tableau  
Ver tabla



**Dossier according to 94/9/EG 8. b ii stored**



По запросу возможна поставка нашей продукции в соответствии со стандартом ATEX.  
On request we can deliver our products according to the ATEX normative.  
Auf Anfrage können wir unsere Produkte den Richtlinien ATEX entsprechend liefern.  
Sur demande nos produits peuvent se conformer a la réglementation ATEX.  
A pedido, se pueden enviar nuestros productos de acuerdo con las normas ATEX.

Перед заказом сверьтесь со стр. 66 ÷ 69  
Before to order see selection "check list" page 66 ÷ 69  
Vor einer Bestellung sollte die "check list" auf den Seiten 66 ÷ 69 gelesen werden.  
Avant de commander, se reporter a la sélection "check list" pages 66 ÷ 69.

Тип  
Type  
Typ  
Types

Габарит  
Size  
Größe  
Taille

Монтаж  
Mounting  
Montage  
Fixation

Передаточное число  
Ratio  
Ubersetzung  
Reduction

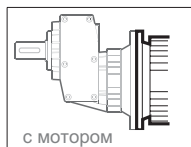
**P****311A****-N****2.84**

с мотором

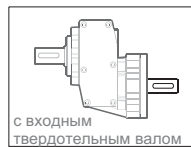
**M**с входным  
твердотельным валом**R**

с моторным фланцем

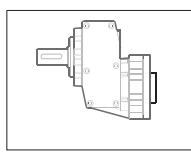
**P****B**

1  
Ступень  
Stages  
Stufen  
Trains  
Etapas

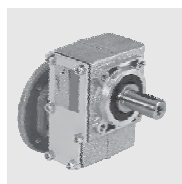

**311A**  $M_{2R} = 30 \text{ Nm}$   
**411A**  $M_{2R} = 50 \text{ Nm}$   
**511A**  $M_{2R} = 118 \text{ Nm}$

Алюминий  
Aluminium  
Aluminium  
Aluminium  
Aluminio

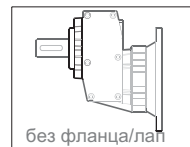

без фланца/лап

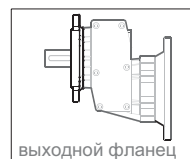
**-N**

выходной фланец

**-F**

съемные лапы

**H1**

Смотри таблицу выбора  
See technical data table  
Technisches Datenblatt  
beachten!  
Voir tableau données  
techniques  
Ver tabla datos técnicos

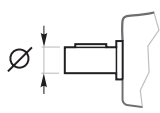
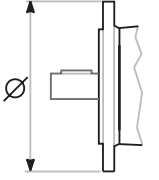
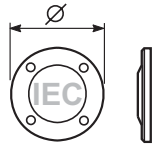
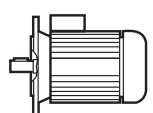
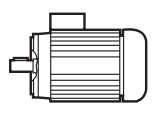
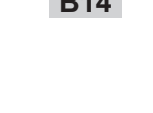
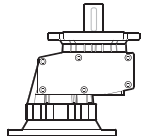
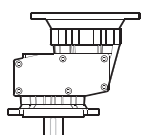
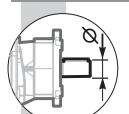
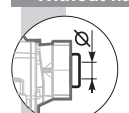
Выходной вал Output shaft Abtriebswelle Arbre lent Eje de salida	Выходной фланец Output flange Ausgangsflansch Bride de sortie Brida de salida	Типоразмер фланца Motor Size Motor Größe Grandeur moteur Tamaco motor	Типоразмер двигателя Motor version Motor bauform Forme constructive moteur Forma constructiva motor	Монтажная позиция Mounting position Einbaulage Position de montage Position de montaje		
<b>S</b>	<b>3</b>	<b>C</b>	<b>B5</b>			
		<p><b>M</b> Без фланца Without flange Ohne Flansch Sans bride Sin brida</p> 		<p>Укажите только для вертикальных позиций Specify only for Vertical positions</p>		
<p>→ СТАНДАРТ</p>						
<p>311A</p> <p><b>S</b> → ∅ 14 <b>C</b> → ∅ 19 <b>E</b> → ∅ 24</p> <p>411A</p> <p><b>S</b> → ∅ 14 <b>C</b> → ∅ 19 <b>E</b> → ∅ 24</p> <p>511A</p> <p><b>C</b> → ∅ 19 <b>E</b> → ∅ 24 <b>G</b> → ∅ 28</p>	<p><b>N</b> Без фланца Without flange Ohne Flansch Sans bride Sin brida</p> <p>311A</p> <p><b>1</b> → ∅ 120 <b>2</b> → ∅ 140 <b>3</b> → ∅ 160 <b>4</b> → ∅ 200</p> <p>411A</p> <p><b>1</b> → ∅ 120 <b>2</b> → ∅ 140 <b>3</b> → ∅ 160 <b>4</b> → ∅ 200</p> <p>511A</p> <p><b>2</b> → ∅ 140 <b>3</b> → ∅ 160 <b>4</b> → ∅ 200 <b>5</b> → ∅ 250</p>	<p><b>B5</b></p> <p><b>A=56</b> (ш120) <b>B=63</b> (ш140) <b>C=71</b> (ш160) <b>D=80</b> (ш200) <b>E=90</b> (ш200) <b>F=100-112</b> (ш250)</p> <p><b>B14</b></p> <p><b>O=56</b> (ш80) <b>P=63</b> (ш90) <b>Q=71</b> (ш105) <b>R=80</b> (ш120) <b>T=90</b> (ш140) <b>U=100-112</b> (ш160) <b>V=132</b> (ш200)</p>	<p><b>B5</b></p>  <p><b>B14</b></p> 	 <p><b>V6</b></p>  <p><b>V5</b></p>		
		<p>Flangia ridotta Reduced Flange</p> <table border="1"> <tr> <td>302A 503A</td> <td>402A 402C 603A 603C</td> </tr> </table> <p><b>1</b> → ш19 (71B5) <b>2</b> → ш24 (80B5)</p> <p><b>3</b> → ш28 (90B5)</p>	302A 503A	402A 402C 603A 603C		
302A 503A	402A 402C 603A 603C					
		<table border="1"> <tr> <td>202A 403A</td> <td>452A 502A 602A 602C</td> </tr> </table> <p><b>5</b> → ш11 (56B5) <b>6</b> → ш14 (63B5) <b>7</b> → ш19 (71B5)</p> <p><b>2</b> → ш24 (80B5) <b>3</b> → ш28 (90B5)</p>	202A 403A	452A 502A 602A 602C		
202A 403A	452A 502A 602A 602C					
		<p>Типо R Type R</p>				
		<p>411A</p> <p>→ СТАНДАРТ <b>2</b> → ш19</p> <p>311A 511A</p> <p><b>1</b> → ш14 <b>3</b> → ш24</p>				
		<p>Без фланца Without flange</p> <p>411A</p> <p><b>Z</b> → ш9 (56B5) <b>0</b> → ш11 (63B5) <b>1</b> → ш14 (71B5)</p> <p>511A</p> <p><b>1</b> → ш14 (71B5) <b>2</b> → ш19 (80B5) <b>3</b> → ш24 (90B5)</p> <p><b>2</b> → ш19 (80B5) <b>3</b> → ш24 (90B5) <b>4</b> → ш28 (100B5)</p>				



Все типоразмеры поставляются залитыми синтетической смазкой на весь срок службы, обслуживание не требуется.

All the units are supplied with synthetic oil for life-time lubrication, no maintenance is necessary.

Alle Getriebes sind mit synthetischem Öl gefüllt und sind lebensdauer-geschmiert.

Les reducteurs sont fournis avec une lubrification permanente a l'huile synthétique et ne demandent aucun entretien.

Los reductores se suministran con lubricación permanente por aceite sintético y no requieren mantenimiento alguna.

Редукторы поставляются с количеством смазки, необходимым для сбора в монтажной позиции B3 / B5.

The gearboxes are furnished with one quantity of oil adapts for the positions of assemblage B3 / B5.

Die Getriebe werden standardmäßig mit der Öl-füllmenge für Einbaulage B3/B5 ausgeliefert.

Les réducteurs sont achalandés avec une quantité d'huile adaptée pour les positions d'assemblage B3 / B5.

Los reductores son dotados con una cantidad de aceite adapta por las posiciones de montaje B3 / B5.

В заказе укажите, если необходимы следующие монтажные позиции: B6 / B56 / V5 / V1 / V6 / V3 / V8 / V58.

Specify in the order, when mounting position are : B6 B56 V5 V1 V6 V3 V8 V58

Bei Montage in den Einbaulagen B6 / B56 / V5 / V1 / V6 / V3 / V8 / V58 ist die Einbaulage in der Bestellung anzugeben.

Dans le cas de jouissance en autres positions type B6 / B56 / V5 / V1 / V6 / V3 / V8 / V58 est nécessaire préciser en phase d'ordre tel choix.

En el caso de empleo en otras posiciones tipo B6 / B56 / V5 / V1 / V6 / V3 / V8 / V58 es necesario precisar en fase de orden tal selección.







Укажите в заказе, если редукторы предназначены для монтажных позиций B3 / B5, но их необходимо использовать для других монтажных позиций, требующих большего количества смазки.

If gearboxes are ordered for B3 B5, but used in different mounting position, just add if your position requires a higher Q.ty.

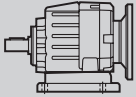
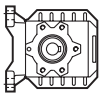
Werden die Getriebe welche für die Einbaulage B3/B5 geliefert wurden in anderen Einbaulagen verwendet ist die Öl-füllmenge entsprechend der Tabelle zu ändern.

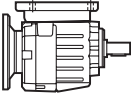
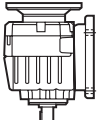
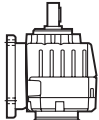
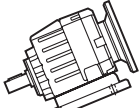
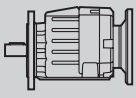
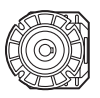
Dans le cas les réducteurs achalandés avec une quantité de lubrifiant pour positions d'assemblage B3 / B5 ils soient utilisés en autres positions il va effectuer une addition d'huile synthétique jusqu'à la quantité totale reportée en tableau.

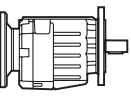
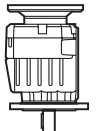
En el caso los reductores dotados con una cantidad de lubricante por posiciones de montaje B3 / B5 sean utilizados en otras posiciones va efectuada una acudadura de aceite sintético hasta la cantidad total reconducida en tablero.

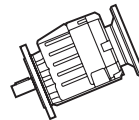
Стандарт	По запросу / On request / Auf Anfrage / A la demande / A solicitud						
 B3	 B6	 B7	 B8	 V5	 V6	 V8	
 B5	 B6	 B7	 B8	 V1	 V3	 V8	

Количество масла / Oil quantity / Ölmenge / Quantités d'huile / Cantidad de aceite [ l ]

202A	0.15	0.15	0.15	0.15	0.15	0.15	0.15
302A	0.15	0.15	0.15	0.15	0.15	0.15	0.15
402A	0.25	0.30	0.40	0.40	0.40	0.50	0.40
403A	0.30	0.35	0.45	0.45	0.45	0.55	0.45
452A	0.31	0.31	0.31	0.31	0.31	0.31	0.31
502A	0.45	0.55	1.00	1.10	1.10	1.15	1.10
503A	0.75	0.75	1.05	1.15	1.20	1.20	1.20
602A	0.55	0.85	1.10	1.20	1.20	1.25	1.20
603A	0.75	0.90	1.15	1.25	1.30	1.35	1.30

Количество масла / Oil quantity / Ölmenge / Quantités d'huile / Cantidad de aceite [ l ]

402C	0.50	0.50	0.50	0.50	0.65	0.85	0.65
403C	0.55	0.55	0.55	0.55	0.70	0.90	0.70
602C	1.00	1.50	1.50	1.50	2.00	2.00	2.00
603C	1.30	1.50	1.50	1.50	2.10	2.00	2.10

Все редукторы поставляются с резьбовой пробкой тип 1.

All the gearboxes are furnished with a solo cork of unloaded / load of the type 1.

Die Getriebe werden standardmäßig mit Verschluss-schrauben ausgeliefert.

Tous les réducteurs sont fournis avec un bouchon seul de charge / déchargement du type 1.

Todos los reductores son provistos con un solista tapón d.e cargado / descargue del tipo 1

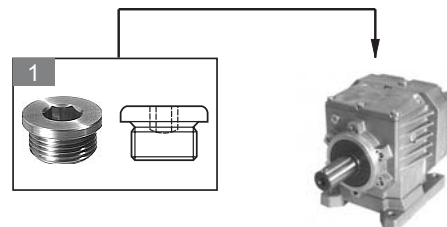









Рекомендованные  
типы смазок

Suggested lubricants

Vorgeschlagene  
Schmierstoffe

Lubrifiants indiqués

Lubricante  
recomendados

СТАНДАРТ		Синтетическая смазка / Synthetic oil			ПО ТРЕБОВАНИЮ ON REQUEST	Минеральная смазка / Mineral oil		
ISO VG		460	220 320	150	680	460	320	220
Окружающая температура Ambient temperature Einsatztemperaturen Temperatura ambiente Tc (°C)		- 15° ÷ 100°	- 25° ÷ 80°	- 30° ÷ 70°	5° ÷ 50°	5° ÷ 45°	- 0° ÷ 40°	- 0° ÷ 35°
ПРОИЗВОДИТЕЛЬ / MANUFACTURER / HERSTELLER / FOURNISSEUR	AGIP		Telium VSF 320	Telium VSF 150	Blasia 680	Blasia 460	Blasia 320	Blasia 220
	BP	Energol SGXP 460	Energol SGXP 220	Energol SGXP 150	Energol GRXP 680	Energol GRXP 460	Energol GRXP 320	Energol GRXP 220
	ESSO				Spartan EP 680	Spartan EP 460	Spartan EP 320	Spartan EP 220
	SHELL	Tivela OIL SD	Tivela OIL WB		Omala OIL 680	Omala OIL 460	Omala OIL 320	Omala OIL 220
	KLUBER	Syntheso D460 EP	Syntheso D220 EP	Syntheso D150 EP	Lamora 680	Lamora 460	Lamora 320	Lamora 220
	MOBIL	Glygoyle HE 460	Glygoyle 30	Glygoyle 22	Mobilgear 636	Mobilgear 636	Mobilgear 632	Mobilgear 630
Тип пробок Oil plugs		  Герметичные Closed			  Открытые (сапун) Open			



## 311 - 411 - 511



Типоразмеры 311, 411, 511 поставляются залитыми синтетической смазкой на весь срок службы, обслуживание не требуется.

All the units 311, 411, 511 are supplied with synthetic oil for lifetime lubrication, no maintenance is necessary.

Die Getriebe 311, 411, 511 sind mit synthetischem Öl gefüllt und sind lebensdauer geschmiert.

Les reducteurs 311, 411, 511 sont fournis avec une lubrification permanente a l'huile synthétique et ne demandent aucun entretien.

Los reductores 311, 411, 511 se suministran con lubricación permanente por aceite sintético y no requieren mantenimiento alguna.

Редукторы поставляются с количеством смазки, необходимым для сбора монтажных позиций B3 / B5.

The gearboxes are furnished with one quantity of oil adapts for the positions of assemblage B3 / B5.

Die Getriebe werden standardmäßig mit der Ölmenge für Einbaulage B3 / B5 ausgeliefert.

Les réducteurs sont achalandés avec une quantité d'huile adaptée pour les positions d'assemblage B3 / B5.

Los reductores son dotados con una cantidad de aceite adapta por las posiciones de montaje B3 / B5.

B3	B5	Кол-во масла / Oil quantity / Ölmenge Quantités d'huile / Cantidad de aceite [ l ]		
		311	411	511
		0.10	0.20	0.29

В заказе укажите, если необходимы следующие монтажные позиции: B6 / B56 / V5 / V1 / V6 / V3 / V8 / V58.

For vertical mounting V5 / V1 / V6 / V3 / V8 / V58 please specify in the order.

Bei Montage in den Einbaulagen V5 / V1 / V6 / V3 / V8 / V58 ist die Einbaulage in der Bestellung anzugeben.

Pour fixation V5 / V1 / V6 / V3 / V8 / V58 S.V.P. nous contacter.

Para montaje V5 / V1 / V6 / V3 / V8 / V58 consultar nos.



РАДИАЛЬНЫЕ И ОСЕВЫЕ НАГРУЗКИ / RADIAL AND AXIAL LOADS /  
 RADIALE UND AXIALE BELASTUNG / CHARGES RADIALES ET AXIALES

Выходной вал / Output shaft / Abtriebswelle / Arbre lent / Eje de salida

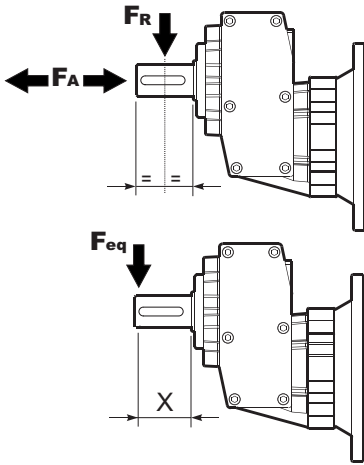

$n_2$ [min <sup>-1</sup> ]	311		411		511	
	$F_A$ [N]	$F_R$ [N]	$F_A$ [N]	$F_R$ [N]	$F_A$ [N]	$F_R$ [N]
700	84	420	182	910	294	1470
600	100	500	200	1000	320	1600
400	115	580	230	1150	370	1850
300	126	630	250	1250	400	2000
200	146	730	290	1450	460	2300
140	160	800	320	1600	510	2550
$F_{eq} =$	$F_R \cdot \frac{38.5}{x+18.5}$		$F_R \cdot \frac{40}{x+20}$		$F_R \cdot \frac{52.5}{x+22.5}$	

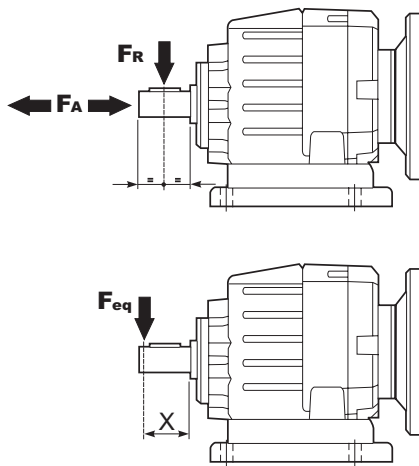

$n_2$ [min <sup>-1</sup> ]	202A 302A		402A 403A		452A		502A 503A		602A 603A	
	$F_A$ [N]	$F_R$ [N]	$F_A$ [N]	$F_R$ [N]	$F_A$ [N]	$F_R$ [N]	$F_A$ [N]	$F_R$ [N]	$F_A$ [N]	$F_R$ [N]
300	140	700	310	1550	415	2070	460	2300	560	2800
250	151	756	330	1650	430	2160	480	2400	600	3000
200	185	924	360	1800	470	2340	520	2600	640	3200
140	246	1320	406	2030	540	2700	600	3000	740	3700
120	270	1350	448	2240	560	2790	620	3100	760	3800
85	300	1500	480	2400	630	3150	700	3500	840	4000
70	340	1700	540	2700	700	3510	780	3900	890	4200
40	380	1900	600	3000	810	4050	900	4500	1160	5800
15			600	3000	900	4500	1000	5000	1300	6500
$F_{eq} =$	$F_R \cdot \frac{35.7}{x+20.7}$		$F_R \cdot \frac{46}{x+21}$		$F_R \cdot \frac{51}{x+21}$		$F_R \cdot \frac{54}{x+24}$		$F_R \cdot \frac{60.5}{x+25.5}$	

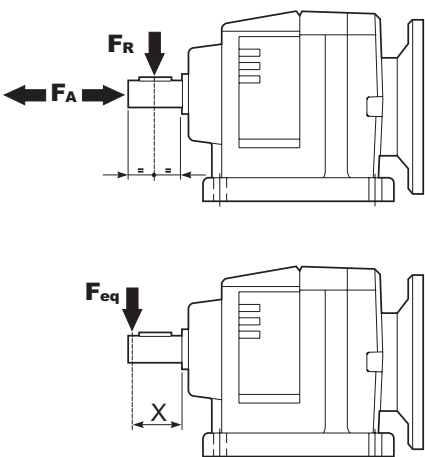

$n_2$ [min <sup>-1</sup> ]	402C 403C		602C 603C	
	$F_A$ [N]	$F_R$ [N]	$F_A$ [N]	$F_R$ [N]
300	400	2000	580	2900
250	440	2200	620	3100
200	470	2350	660	3300
140	540	2700	760	3800
120	590	2900	800	4000
85	680	3400	960	4800
70	760	3800	1000	5000
40	860	4300	1200	6000
15	860	4300	1452	7260
$F_{eq} =$	$F_R \cdot \frac{46}{x+21}$		$F_R \cdot \frac{60.5}{x+25.5}$	



Входной вал / Input shaft / Antriebswelle / Arbre rapide / Eje de entrada

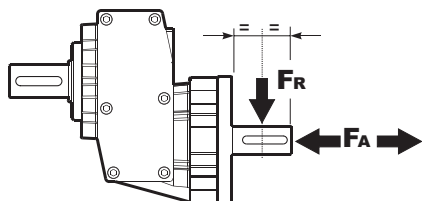

n <sub>1</sub> [min <sup>-1</sup> ]	311		411		511	
	F <sub>A</sub> [N]	F <sub>R</sub> [N]	F <sub>A</sub> [N]	F <sub>R</sub> [N]	F <sub>A</sub> [N]	F <sub>R</sub> [N]
1400	140	700	240	1200	400	2000
900	160	800	280	1400	440	2200

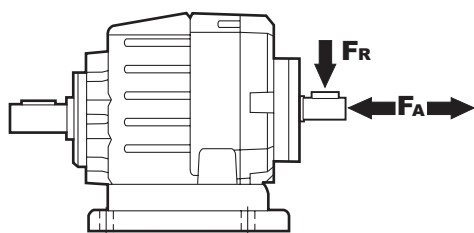

n <sub>1</sub> [min <sup>-1</sup> ]	202A		302A		402A		403A		452A 502A		503A		602A		603A	
	F <sub>A</sub> [N]	F <sub>R</sub> [N]	F <sub>A</sub> [N]	F <sub>R</sub> [N]	F <sub>A</sub> [N]	F <sub>R</sub> [N]	F <sub>A</sub> [N]	F <sub>R</sub> [N]	F <sub>A</sub> [N]	F <sub>R</sub> [N]	F <sub>A</sub> [N]	F <sub>R</sub> [N]	F <sub>A</sub> [N]	F <sub>R</sub> [N]	F <sub>A</sub> [N]	F <sub>R</sub> [N]
1400	140	700	226	1130	240	1200	140	700	400	2000	240	1200	450	2250	400	2000
900	160	800	264	1320	280	1400	160	800	440	2200	280	1400	500	2500	440	2200
500	190	950	322	1610	340	1700	190	950	440	2200	310	1700	600	3000	440	2200

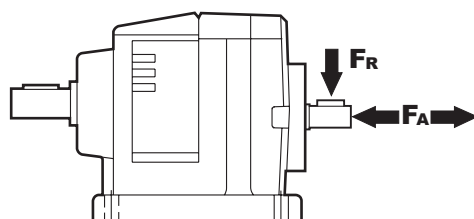

n <sub>1</sub> [min <sup>-1</sup> ]	402C		403C		602C		603C	
	F <sub>A</sub> [N]	F <sub>R</sub> [N]	F <sub>A</sub> [N]	F <sub>R</sub> [N]	F <sub>A</sub> [N]	F <sub>R</sub> [N]	F <sub>A</sub> [N]	F <sub>R</sub> [N]
1400	240	1200	240	1200	450	2250	400	2000
900	280	1400	280	1400	500	2500	440	2200
500	340	1700	340	1700	600	3000	440	2200

$$F_R [N] = \frac{M \cdot 2000}{d} \cdot f_k$$

M [Nm]	Выходной крутящий момент / Output torque / Drehmoment / Couple / Par torsor
d [mm]	Диаметр приводного элемента / Diam. of driving element / Durchmesser / Diametre / Diámetro primitivo
f <sub>k</sub> =	Коэффициент трансмиссии / Factor / bbertragungsfaktor / Coefficient / Coeficiente de transmisiyn
1.15	Шестерня / Gearwheels / Zahnrad / Engrenage / Engranaje
1.25	Приводная цепь / Chain sprochets / Antriebskette / Chaone / Cadena
1.75	V-образный ремень / Narrow v-belt pulley / Keilriemen / Courroie trap. / Correa trapezoidal.
2.5	Плоский ремень / Flat-belt pulley / Flachzahnriem. / Courroie crantïe / Correa plana

- При более высоких радиальных нагрузках, свяжитесь с Поставщиком. Более высокие нагрузки могут быть возможны.
- If your application requires higher radial loads contact our technical office, it is in practice often possible to apply higher loads.
- Wenn Ihre Anwendung höhere Radialbelastungen erfordert, so wenden Sie sich bitte an unser technischen Büro.
- Si votre application demande des charges radiales supérieures, s'adresser a notre bureau technique.
- En ei caso en que una aplicaciyn exija una carga radial superior a la especificada en el catálogo, consultara nuestras oficina tecnica.



# ВЫБОР РЕДУКТОРОВ / GEARBOXES SELECTION / GETRIEBEAUSWAHL SELECTION REDUCTEURS / SELECCION REDUCTOR

## Как выбрать редуктор / How to select a gearbox / Wie wählt man ein Getriebe Comment sélectionner un réducteur / Como seleccionar un reductor

**B** Выходная скорость  
Output speed  
Abtriebsdrehzahl  
Vitesse de sortie  
Velocidad de salida

Номинальная мощность  
Nominal power  
Max. mögliche Leistung  
Puissance nominale  
Potencia nominal

Код моторного фланца  
Flange code  
Flanschtype  
Code bride

Пометки  
Notes  
Anmerkungen  
Note  
Notas

Мощность двигателя  
Motor power  
Motorleistung  
Puissance moteur

Сервис-фактор  
Service factor  
Betriebsfaktor  
Facteur de service  
Factor de servicio

**A** Номинальный момент  
Nominal torque  
Nenn-Drehmoment  
Couple nominal  
Par de torsion nominal

Динамический КПД  
Dynamic efficiency  
Dynamischer Wirkungsgrad  
Rendement dynamique  
Rendimiento dinámico

n <sub>2</sub> [min <sup>-1</sup> ]	i	P <sub>1M</sub> [kW]	M <sub>2M</sub> [Nm]	fs	P <sub>1R</sub> [kW]	M <sub>2R</sub> [Nm]		B5					B14					RD	 Ratios code	
								B	C	D	E	F	O	P	Q	R	T			U
								B	C	D	E	F	O	P	Q	R	T	U		
								63	71	80	90	100 112	56	63	71	80	90	100 112		

**302** n<sub>1</sub> = 1400 min<sup>-1</sup>

407	<b>3.44</b>	1.5	34	1.5	<b>2.2</b>	50	20	B								B-C	C		96	2821
327	<b>4.28</b>	1.5	42	1.2	<b>1.8</b>	50	20	B								B-C	C		96	2818
257	<b>5.45</b>	1.5	54	0.9	<b>1.4</b>	50	20	B								B-C	C		96	2815
225	<b>6.23</b>	1.5	61	1.1	<b>1.7</b>	70	20	B								B-C	C		96	1921
194	<b>7.20</b>	1.5	71	1.0	<b>1.5</b>	70	20	B								B-C	C		96	2812

**C** Передаточное число  
Ratio  
Untersetzung  
Rapport de réduction

Диаметр выходного вала  
Output shaft diam.  
Durchmesser Abtriebswelle  
Diamètre arbre de sortie  
Diametro eje de salida

Типоразмер редуктора  
Gear size  
Getriebegröße  
Taille réducteur  
Tamazo reductor

Входная скорость  
Input speed  
Eintriebsdrehzahl  
Vitesse d'entrée  
Velocidad de entrada

Передаваемый момент  
Transmitted torque  
Übertragenes Drehmoment  
Couple de sortie  
Par transmitido

**D** Возможные моторные фланцы  
Motor flange available  
Erhältliche Motorflansche  
Bridas disponibles  
Bridas disponibles

Отношение зубьев  
Preferential ratio  
Untersetzung  
Rapport de réduction conseillé  
Relaciyn preferente

**B)** Монтируются с проставкой  
Coupling by means of reduction bushing  
Reduzierhülzen  
Montage avec douille de réduction  
Montaje con casquillo de reducciyn

**C)** Положение отверстий в моторном фланце редуктора  
Motor flange/terminal box position  
Bohrungsposition am Motorflansch/-sockel  
Position trous bride/barrette a bornes moteur  
Posiciyn agujeros brida / base motor

<b>A</b>	Выберите требуемый крутящий момент (в соответствии с сервис фактором)	Select required torque (according to service factor)	Max. Drehmoment in Bezug zum Betriebsfaktor	Sélectionner le couple souhaité (comprenant le facteur de service)	Seleccionar el par deseado (incluyendo el factor de servicio)
<b>B</b>	Выберите скорость на выходе	Select output speed	Ausgewählte Abtriebsdrehzahl	Sélectionner la vitesse en sortie	Seleccionar la velocidad de salida
<b>C</b>	На одной линии с мотор-редуктором вы найдете передаточное число.	On the same line of selected motorization, you can find the gear ratio	Auf der gleichen Linie wie die ausgewählte Motorleistung steht auch die Getriebeuntersetzung	Sur la ligne correspondante a la motorisation pré-choisie on peut relever le rapport de réduction	En la línea correspondiente al motor preseleccionado es posible encontrar la relación de reducción
<b>D</b>	Выберите доступный моторный фланец (по заказу)	Select motor flange available (if requested)	Erhältliche Motorflansche (auf Anfrage)	Choisir la bride disponible (si elle est demandée)	Seleccionar la brida disponible (sobre pedido)







# 38 Nm

# Алюминий

n <sub>2</sub> [min <sup>-1</sup> ]	i	P <sub>1M</sub> [kW]	M <sub>2M</sub> [Nm]	fs	P <sub>1R</sub> [kW]	M <sub>2R</sub> [Nm]		B5					B14					RD	 Код перед. числа	
								B	C	D	E	F	O	P	Q	R	T			U
								63	71	80	90	100 112	56	63	71	80	90			100 112

## 411

n<sub>1</sub> = 1400 min<sup>-1</sup>

892	1.57	1.5	15.5	2.6	3.9	41	19/24	B								C	C			98	2844
493	2.84	1.5	28.5	1.5	2.2	43	19/24	B								C	C			98	1954
426	3.29	1.5	33	1.5	2.2	49	19/24	B								C	C			98	1756
362	3.87	1.5	39	1.0	1.6	41	19/24	B								C	C			98	1558
303	4.62	1.5	46.3	1.0	1.6	49	19/24	B								C	C			98	1360
222	6.30	1.1	46.3	1.0	1.1	47	19/24	B								C	C			98	1063
170	8.22	0.55	30	1.3	0.70	39	19/24	B								C	C			98	974
130	10.86	0.37	27	1.1	0.39	28	19/24	B								C	C			98	776

### P411-N

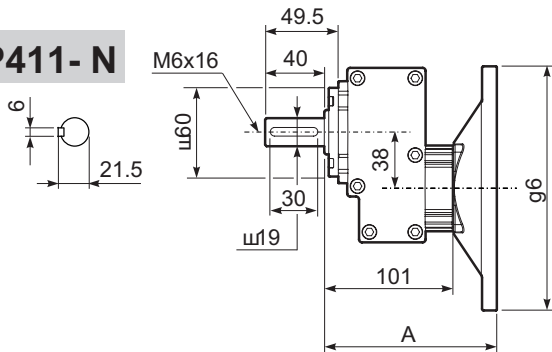

Nr<sup>o</sup>4 - M8x14

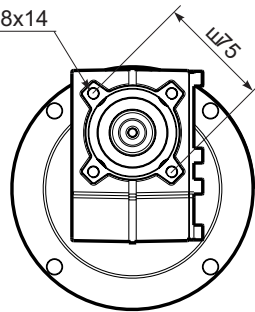

### Тип 411 (Моторный фланец)

Моторный фланец	A	g6	k1
71 B14	119.5	105	123
80 B14	120.5	120	124
90 B14	121.5	140	125
100/112 B14	119.5	160	123
63 B5	121.5	140	125
71 B5	119.5	160	123
80/90 B5	121.5	200	125

### Выходной фланец / Output flange

a1 Ш	b1	e1	c1	f1	s1
120	80	100	11.5	3	9*
140	95	115	11.5	3	9
160	110	130	11.5	3.5	9
200	130	165	11.5	3.5	11

\* Положение отверстий / holes position

### Ш Выходной вал / Ш Output uscita

Стандарт	Ш 19x40
По запросу	Ш 24x40
По запросу	Ш 14x30

Масса / Weight: 3.20 Kg

### P411-F

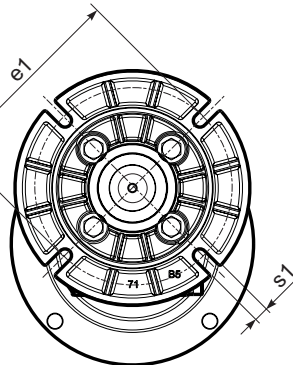
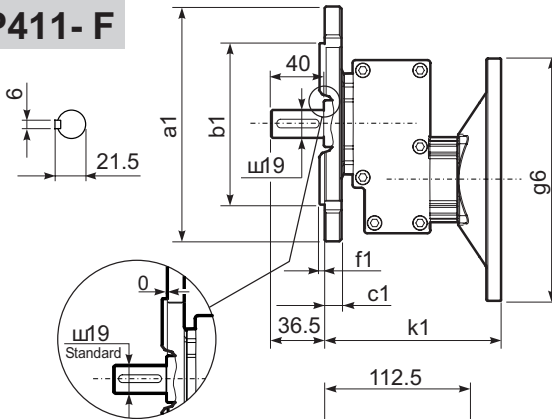

### R411-N

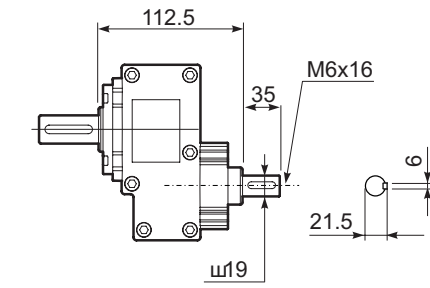

### R411-H1

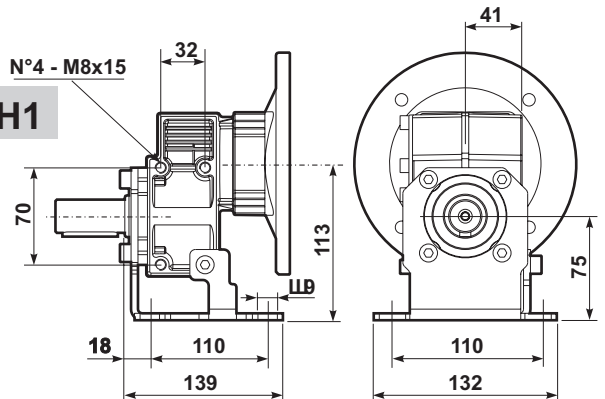

### P411-N

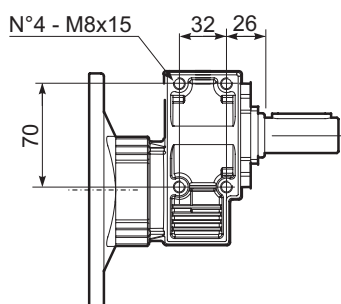

<b>B)</b>	Монтируется с проставкой Coupling by means of reduction bushing	
<b>C)</b>	Положение отверстий моторного фланца редуктора Motor flange/terminal box position	



# 118 Nm

# Алюминий

n <sub>2</sub> [min <sup>-1</sup> ]	i	P <sub>1M</sub> [kW]	M <sub>2M</sub> [Nm]	fs	P <sub>1R</sub> [kW]	M <sub>2R</sub> [Nm]		B5					B14					RD	 Код перед. числа		
								B	C	D	E	F	O	P	Q	R	T			U	V
								63	71	80	90	100 112	56	63	71	80	90	100 112	132		

## 511

n<sub>1</sub> = 1400 min<sup>-1</sup>

1077	1.30	4	35	1.9	7.7	67	24/28	B											98	3039
571	2.45	4	66	1.9	7.4	122	24/28	B											98	2049
423	3.31	4	89	1.4	5.5	122	24/28	B											98	1653
325	4.31	4	115	1.2	4.6	133	24/28	B											98	1356
266	5.27	3	106	1.3	3.8	133	24/28	B											98	1158
183	7.63	2.2	112	1.0	2.2	114	24/28	B											98	861
133	10.50	1.1	77	1.0	1.1	79	24/28	B											98	663

### P511-N

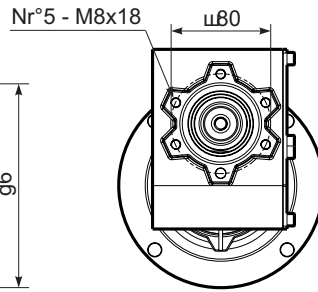
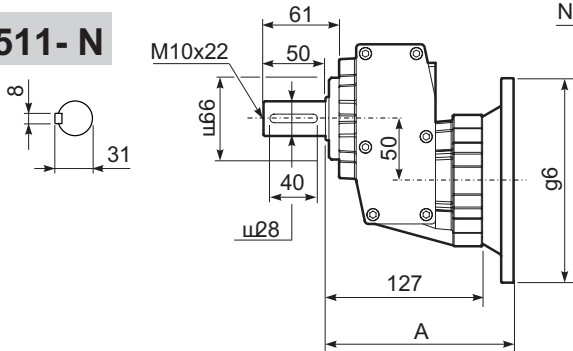

### Тип 511 (Моторный фланец)

Моторный фланец	A	g6	k1
84 B14	145	7120	149,5
90 B14	145	140	149,5
100/112 B14	145	160	149,5
132 B14	175	200	188
71 B5	145	160	149,5
80/90 B5	147	200	151,5
100/112 B5	153	250	157,5

### Выходной фланец / Output flange

a1 Ш	b1	e1	c1	f1	s1
140	95	115	10	3	
160	110	130	10	3,5	
200	130	165	11	3,5	
250	180	215	11,5	3,5	

\* Положение отверстий / holes position

### Ш Выходной вал / Output shaft

Стандартный	Ш 28x50
По запросу	Ш 24x50

Масса Weight	5.00 Kr
--------------	---------

### P511-F

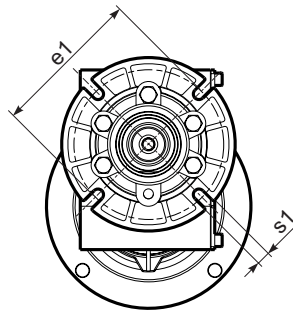
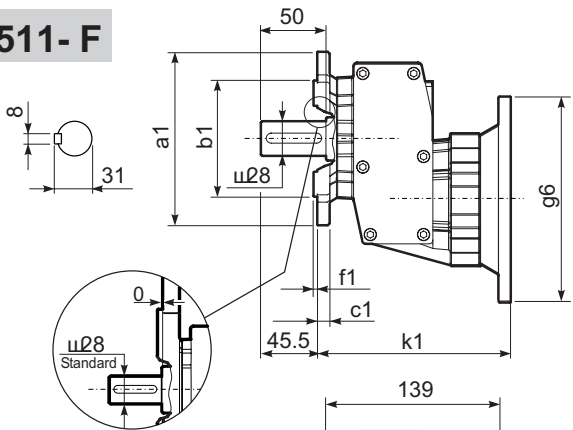

### R511-N

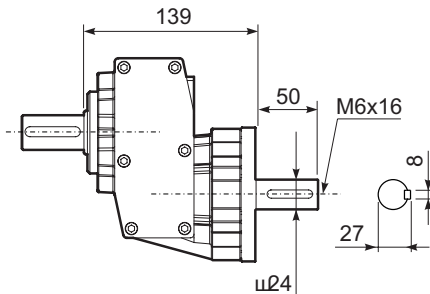

### R511-H1

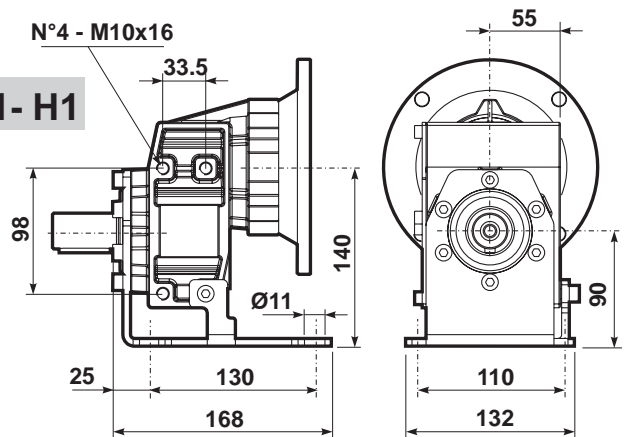

### P511-N

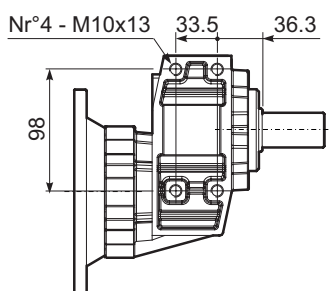

**B)** Монтируется с проставкой  
Coupling by means of reduction bushing



**C)** Положение отверстий моторного фланца редуктора  
Motor flange/terminal box position







**P202A-N**

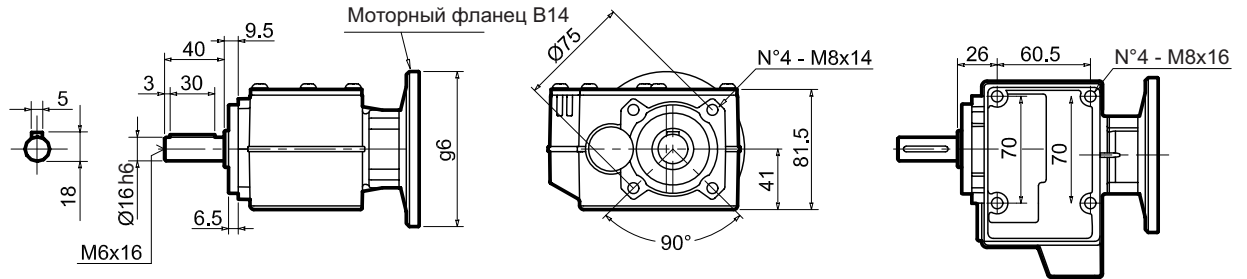

**P202A-F**

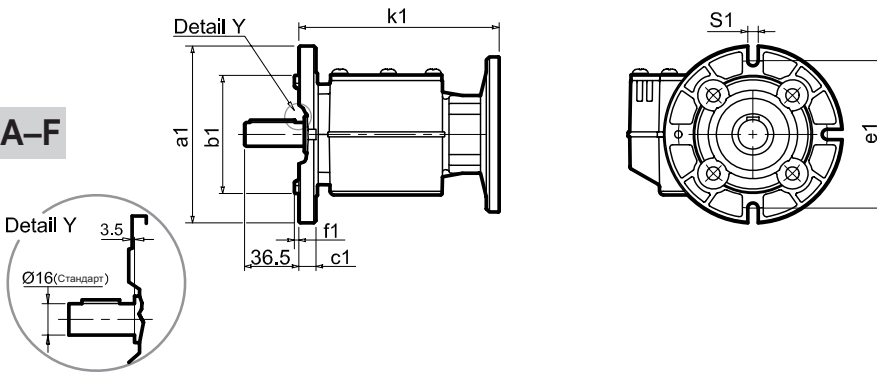

**Выходной фланец / Output flange**

a1 Ø	b1	e1	c1	f1	s1
120	80	100	11.5	3	9
140	95	115	11.5	3	9*
160	110	130	11.5	3.5	9*
200	130	165	11.5	3.5	11*

\* Положение отверстий / Holes position

Ø Выходной вал / Ø Output shaft	Стандарт	Ø16x40
	По запросу	Ø14x30 Ø20x40 Ø25x50

**Масса (кг) с фланцем 3.3**  
**Масса (кг) с лапами 3.7**

**R202A-N**

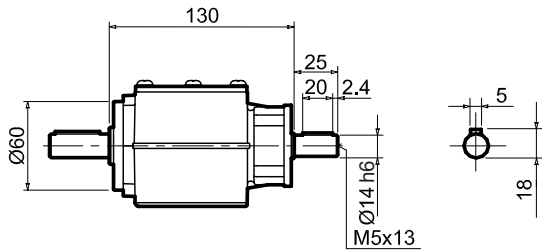

**P202A....**

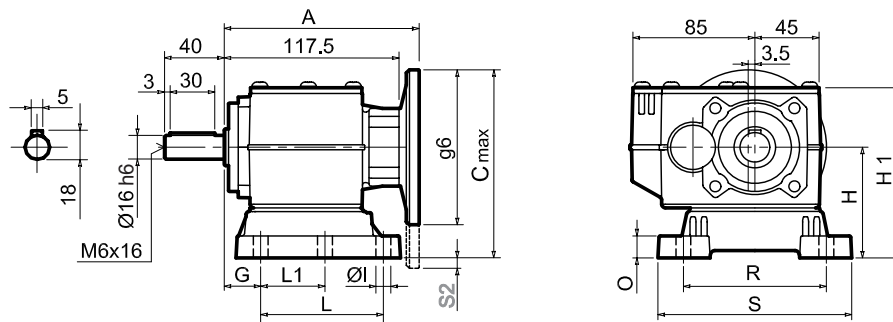

**Тип 202A (моторные фланцы)**

Моторные фланцы	A	C max	g6	k1
56 B14	137.5	139	78	147.2
63 B14	133.5	146	90	143.2
71 B14	133	152.5	105	142.7
63 B5	133.5	170	140	143.2
71 B5	131.5	180	160	141.2

**Возможные размеры лап / Available feet dimensions**

Market reference	Код лапы	G	H	R	L	L1	S	H1	O	Ø1	S2 with motor flange	B5 max. flange
102	B1	18	85	110	87	50	130	125	15	9	5 71 B5	
Old 20	B2	18	100	130	107.5	60	155	145	5	11		
17 - 32	S1	18	75	110	110	50	130	115.5	15	9		63 B5
03	L 3	12.5	65	91	60		105	149	5	9	11.5 71 B5	
04	L 4	13	80	105	76		132	165	5	9		

Вы найдете коды в таблицах напротив нужных размеров

Checking the main dimensions (G - H - R - L) you will find the codes (S1 - B1 - etc.) of your need

Наиболее популярные типы / Most popular types







**P302A-N**

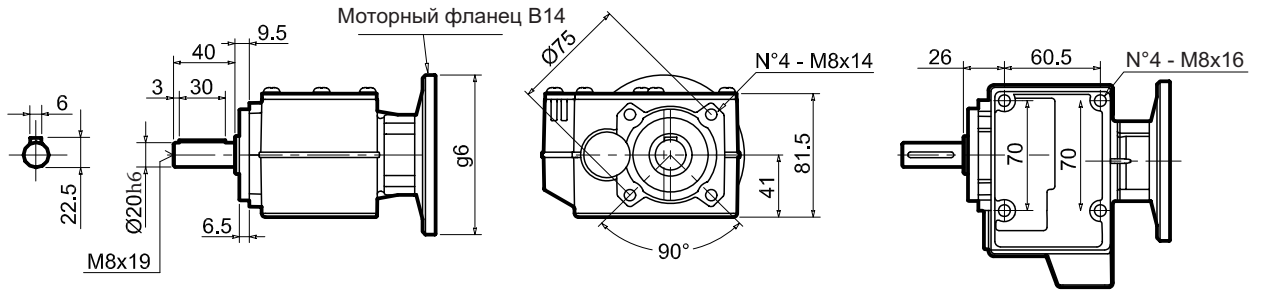

**P302A-F**

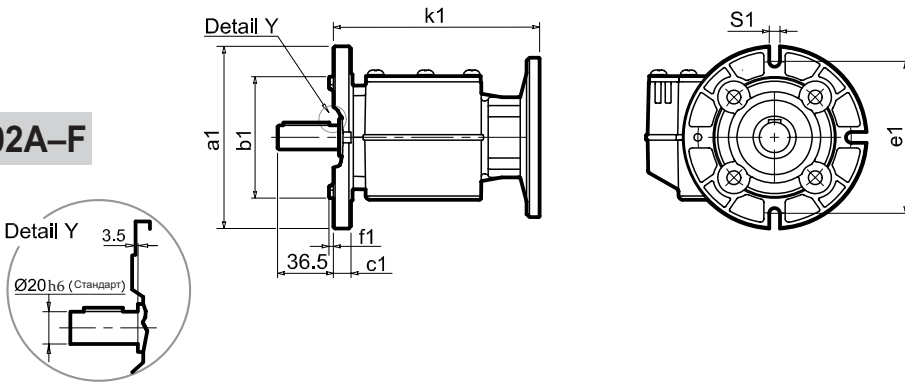

**Выходной фланец / Output flange**

a1 Ø	b1	e1	c1	f1	s1
120	80	100	11.5	3	9
140	95	115	11.5	3	9*
160	110	130	11.5	3.5	9*
200	130	165	11.5	3.5	11*

\* Положение отверстий / Holes position

Стандарт	Ø 20x40
По запросу	Ø 14x30 Ø 16x40
On request	Ø 25x50

ØВыходной вал  
ØOutput shaft

Масса (кг) с фланцем 3.5  
Масса (кг) с лапами 4.0

**R302A-N**

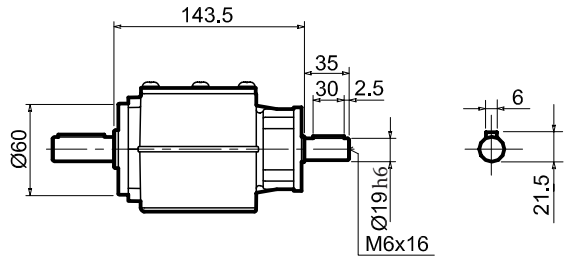

**P302A....**

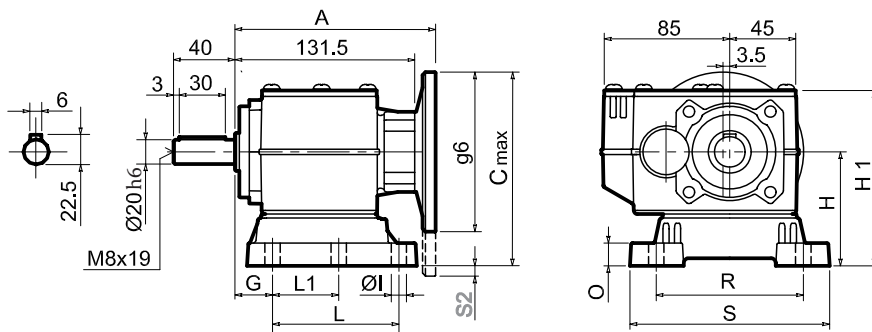

Тип 202A (моторные фланцы)

Моторные фланцы	A	C max	g6	k1
71 B14	149.5	152.5	105	159.2
80 B14	150.5	160	120	160.2
90 B14	151.5	170	140	161.2
63 B5	151.5	170	140	161.2
71 B5	149.5	180	160	159.2
80/90 B5	151.5	200	200	161.2

Возможные размеры лап / Available feet dimensions

Market reference	Код лапы	G	H	R	L	L1	S	H 1	O	Ø1	S2 With motor flange	B5 max. flange
102	B1	18	85	110	87	50	130	125	15	9	15 80/90 B5	
202/3	B2	18	100	130	107.5	60	155	145	5	11	3.5 80/90 B5	
17 - 32	S1	18	75	110	110	50	130	115.5	15	9	5 71 B5	71 B5
27	S2	25	90	110	130		130		5	9		
03	L 3	12.5	65	91	60		105	149	5	9	31.5 80/90 B5	
04	L 4	13	80	105	76		132	165	5	9	16.5 80/90 B5	



Вы найдете коды в таблицах напротив нужных размеров

Checking the main dimensions (G - H - R - L) you will find the codes (S1 - B1 - etc.) of your need.

Наиболее популярные типы  
Most popular types





	402A	403A
X	7	3.2

402A	403A
------	------

Масса (кг) с фланцем 5.7 6.1  
Масса (кг) с лапами 5.9 6.3

P402A-N  
P403A-N

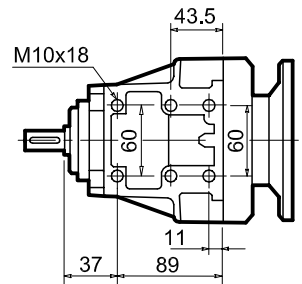
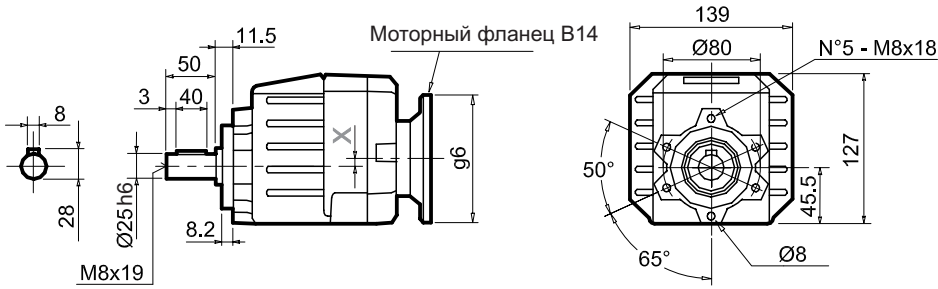

Выходной фланец / Output flange

a1 Ø	b1	e1	c1	f1	s1
120	80	100	10	3	9
140	95	115	10	3	9
160	110	130	10	3	9
200	130	165	11	3.5	11
250	180	215	11.5	—	—

Ø Выходной вал / Output shaft  
Стандарт Ø 25x50  
По запросу / On request Ø 16x40 Ø 19x40 Ø 20x40 Ø 24x50

P402A-F  
P403A-F

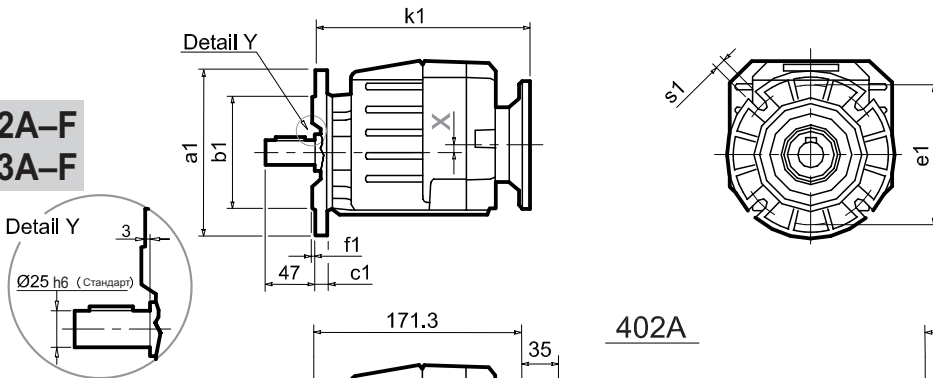

R402A-N  
R403A-N

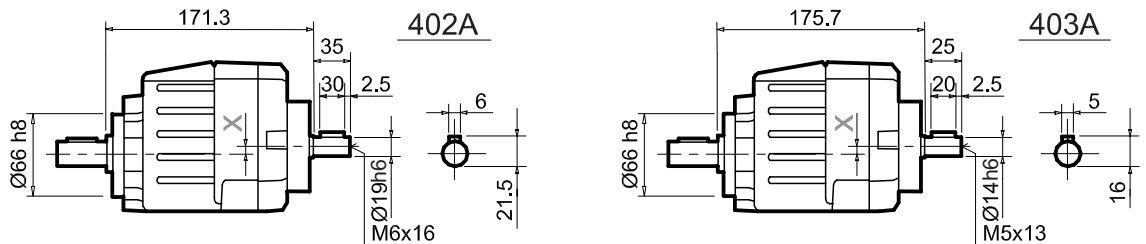

P402A....  
P403A....

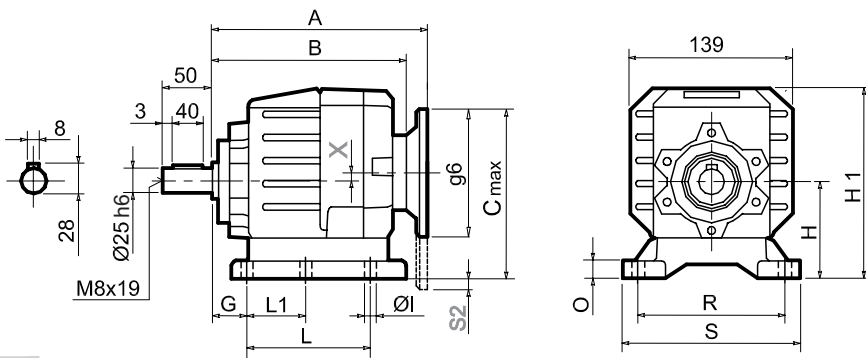

Тип 402A (моторные фланцы)

Моторные фланцы	A	B	C max	g6	k1
71 B14	178.5	160	142.5	105	181.5
80 B14	179.5		150	120	182.5
90 B14	180.5		160	140	183.5
63 B5	180.5		162	140	183.5
71 B5	178.5		170	160	181.5
80/90 B5	180.5	190	200	183.5	
100/112B14	195.5	170	160	199.5	

Тип 403A (моторные фланцы)

Моторные фланцы	A	B	C max	g6	k1
56 B14	186.5	166	170.2	78	189.5
63 B14	181.5		176.2	90	184.5
71 B14	182	183.7	105	185	
63 B5	182.5	201.2	140	185.5	
71 B5	180.5	211.2	160	183.5	

Возможные размеры лап / Available feet dimensions

Market reference	Код лапы	G	H	R	L	L1	S	H 1	O	Ø1	S2 With motor flange	B5 max. flange
102	B1	18	85	110	87	50	130	167	15		8 80/90 B5	
202/3	B2	18	100	130	107.5	60	155	182	17	11		
17	S1	18	75	110	90 + 20	50	145	155	15	9	18 80/90 B5	
27	S2	25	90	110	130		145	172	20	9	3 80/90 B5	
020 - 021	H 1	18	80	110	90		135	162	14	9	13 80/90 B5	
022 - 223	H 2	25	100	110	115		145	182	20	9		
04	L 4	13	80	105	76		132	162	5	10	13 80/90 B5	
05	L 5	16	100	125	90		150	182	6	12		
2002/3	E 0	18	75	110	85		150	157	5	10	18 80/90 B5	
2102/3	E 1	16	80	110	165		165	162	6	12		71 B5
42/3	M1	25	80	110-120	85		145	162	15	9	13 80/90 B5	
102	P 0	20	102	100	106		125	184	5	10		
128	P 2	24	128	118	126		166	210	6	12		
4075-85G	J 1	16 - 17	80	120	55 + 65		160	162	6	10	13 80/90 B5	
4090-95G	J 2	25	100	150	90		175	182	6	12		

Вы найдете коды в таблицах напротив нужных размеров

Checking the main dimensions (G - H - R - L) you will find the codes (S1 - B1 - etc.) of your need

Наиболее популярные типы / Most popular types



# 195 Nm

# Чугун

n <sub>2</sub> [min <sup>-1</sup> ]	i	P <sub>1M</sub> [kW]	M <sub>2M</sub> [Nm]	fs	P <sub>1R</sub> [kW]	M <sub>2R</sub> [Nm]		B5					B14					RD	 Код перед. числа	
								B	C	D	E	F	O	P	Q	R	T			U
								63	71	80*	90*	100 112	56	63	71	80	90			100 112

## 402C

n<sub>1</sub> = 1400 min<sup>-1</sup>

n <sub>2</sub>	i	P <sub>1M</sub>	M <sub>2M</sub>	fs	P <sub>1R</sub>	M <sub>2R</sub>	Motor flange	B5	B14	RD	Code	Mark
252	5.55	3	109	1.1	3.3	120	24/25	B	C C	96	2815	●
191	7.33	3	144	1.0	3.1	150	24/25	B	C C	96	2812	
156	8.96	3	176	0.9	2.7	160	24/25	B	C C	96	2810	
139	10.04	2.2	145	1.0	2.3	150	24/25	B	C C	96	1915	●
120	11.64	2.2	168	1.0	2.1	160	24/25	B	C C	96	1715	
106	13.26	2.2	191	0.9	2.1	180	24/25	B	C C	96	1912	
91	15.37	1.5	151	1.3	1.9	196	24/25	B	C C	96	1712	●
86	16.20	1.5	159	1.1	1.6	170	24/25	B	C C	96	1910	
75	18.78	1.5	184	0.9	1.4	170	24/25	B	C C	96	1710	
65	21.54	1.1	155	1.3	1.4	196	24/25	B	C C	96	1312	●
63	22.26	1.1	160	1.0	1.1	155	24/25	B	C C	96	1015	
53	26.31	0.75	129	1.3	0.99	170	24/25	B	C C	96	1310	●
47.6	29.40	0.75	144	1.4	1.0	196	24/25	B	C C	96	1012	
39.0	35.91	0.75	176	1.0	0.72	170	24/25	B	C C	96	1010	●
36.5	38.37	0.55	138	1.3	0.72	180	24/25	B	C C	96	912	
29.9	46.87	0.55	169	1.0	0.55	170	24/25	B	C C	96	910	
27.6	50.67	0.37	123	1.2	0.45	150	24/25	B	C C	96	712	
22.6	61.89	0.37	150	1.1	0.42	170	24/25	B	C C	96	710	

## 403C

n<sub>1</sub> = 1400 min<sup>-1</sup>

n <sub>2</sub>	i	P <sub>1M</sub>	M <sub>2M</sub>	fs	P <sub>1R</sub>	M <sub>2R</sub>	Motor flange	B5	B14	RD	Code	Mark
36.5	38.34	0.75	182	1.0	0.72	175	24/25	B	C C	93	171715	●
32.0	43.69	0.75	208	0.9	0.70	195	24/25	B	C C	93	191712	
27.6	50.64	0.37	119	1.6	0.61	195	24/25	B	C C	93	171712	●
22.5	62.22	0.37	146	1.3	0.49	195	24/25	B	C C	93	191312	
19.7	70.95	0.37	167	1.2	0.43	195	24/25	B	C C	93	131712	●
18.7	74.77	0.37	176	1.0	0.37	175	24/25	B	C C	93	191310	
16.2	86.66	0.37	203	0.9	0.32	175	24/25	B	C C	93	131710	
14.5	96.85	0.25	154	1.3	0.32	195	24/25	B	C C	93	101712	●
11.8	118.29	0.25	188	0.9	0.23	175	24/25	B	C C	93	101710	
10.3	135.69	0.18	155	1.3	0.23	195	24/25	B	C C	93	101312	
8.4	165.74	0.18	189	0.9	0.17	175	24/25	B	C C	93	101310	

\* В монтажной позиции P моторный фланец B5 может не соответствовать размерам. Проверьте размеры и по возможности используйте фланец B14.  
 In the P mounting the B5 motor flange can exceed the foot maximum dimensions. Check on the dimensions and possibly use the flange B14.  
 Der Motoreingangsflansch in B5 kann größer sein als die Getriebeßaße. In diesem Falle sollte ein B-14 Flansch genommen werden.  
 Lors d'un montage en forme P la bride peut dépasser des pattes. Vérifier dans les tableaux des dimensions et utiliser si possible une bride B14.  
 En el montaje P la brida puede exceder de les dimensiones máximas de las patas. Verificar en los esquemas dimensionales, asm como la posibilidad de usar la brida B14.

B, C, ...	Возможные моторные фланцы Motor flange available	B	Монтируются с проставкой Coupling by means of reduction bushing		C	Положение отверстий моторного фланца редуктора Motor flange/terminal box position	
-----------	---	---	--	--	---	--	--





P402C-N  
P403C-N

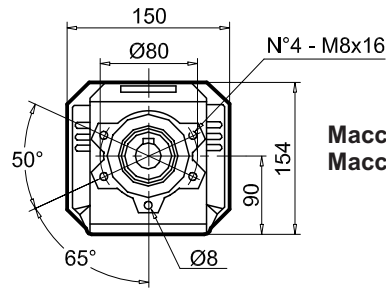
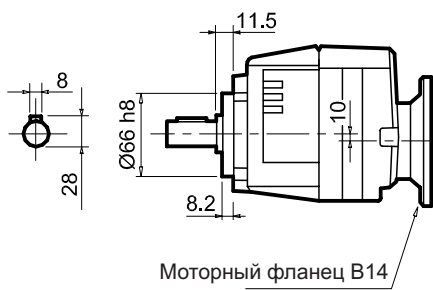

402C	403C
------	------

Масса (кг) с фланцем 8.2 8.7  
Масса (кг) с лапами 9.5 10

P402C-F  
P403C-F

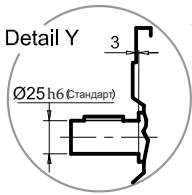
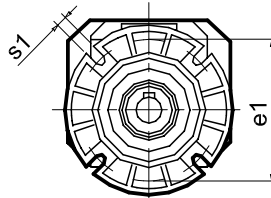
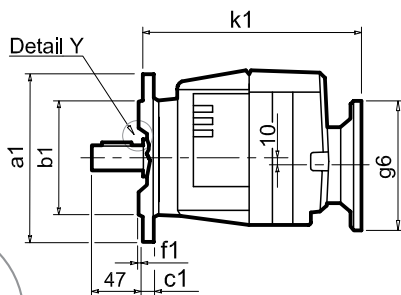

Выходной фланец / Output flange

a1 Ø	b1	e1	c1	f1	s1
120	80	100	10	3	9
140	95	115	10	3	9
160	110	130	10	3	9
200	130	165	11	3.5	11

Стандарт	Ø 25x50
По запросу	Ø 16x40 Ø 19x40
On request	Ø 20x40 Ø 24x50

ØВыходной вал  
ØOutput shaft

R402CSP  
R403CSP

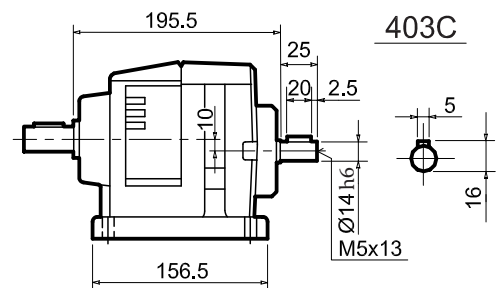
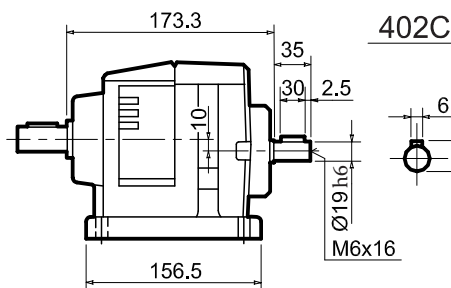

P402CSP  
P403CSP

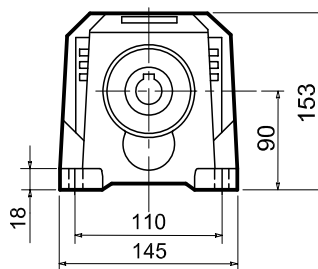
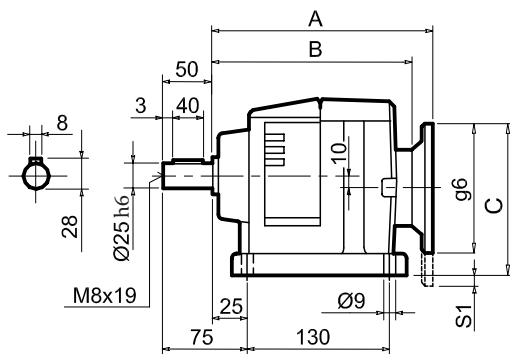

Тип 402C (моторные фланцы)

Моторные фланцы	A	B	C	g6	S1	k1
71 B14	180.5	162	133	105		183.5
80 B14	181.5		140	120		184.5
90 B14	182.5		150	140		185.5
63 B5	182.5		150	140		185.5
71 B5	180.5		160	160		183.5
80/90 B5	182.5	190	200	10		185.5

Тип 403C (моторные фланцы)

Моторные фланцы	A	B	C	g6	S1	k1
71 B14	202	183.5	133	105		205
80 B14	203		140	120		206
90 B14	204		150	140		207
63 B5	204		150	140		207
71 B5	202		160	160		205
80/90 B5	203	190	200	10		206



# 300 Nm

# Алюминий

n <sub>2</sub> [min <sup>-1</sup> ]	i	P <sub>1M</sub> [kW]	M <sub>2M</sub> [Nm]	fs	P <sub>1R</sub> [kW]	M <sub>2R</sub> [Nm]		B5					B14					RD	 Код перед. числа		
								B	C	D	E	F	O	P	Q	R	T			U	V
								63	71	80	90	100* 112	56	63	71	80	90			100 112	132

## 452A

n<sub>1</sub> = 1400 min<sup>-1</sup>

n <sub>2</sub>	i	P <sub>1M</sub>	M <sub>2M</sub>	fs	P <sub>1R</sub>	M <sub>2R</sub>	28/30/35	B	C	D	E	F	O	P	Q	R	T	U	V	RD	Код перед. числа	
388	3.61	4	95	1.6	6.3	150	28/30/35	B												96	3018	
331	4.23	4	111	1.5	6.1	170	28/30/35	B													96	3016
279	5.01	4	131	1.5	6.1	200	28/30/35	B													96	3014 ●
231	6.07	4	159	1.6	6.3	250	28/30/35	B													96	3012
206	6.81	4	178	1.6	6.2	277	28/30/35	B													96	2018
176	7.96	4	209	1.4	5.8	300	28/30/35	B													96	2016
148	9.45	4	248	1.2	4.9	304	28/30/35	B													96	2014 ●
122	11.43	4	299	1.0	4.0	300	28/30/35	B													96	2012
99	14.21	3	279	0.9	2.8	265	28/30/35	B													96	2010
84	16.62	3	327	0.9	2.8	304	28/30/35	B													96	1314 ●
70	20.10	2.2	290	1.0	2.3	300	28/30/35	B													96	1312 ●
56	24.98	1.85	303	0.9	1.6	265	28/30/35	B													96	1310 ●
47.6	29.41	1.5	289	1.1	1.6	304	28/30/35	B													96	814
39.3	35.58	1.5	349	0.9	1.3	300	28/30/35	B													96	812
34.6	40.50	1.1	292	1.0	1.1	290	28/30/35	B													96	614
31.7	44.22	1.1	319	0.8	0.92	265	28/30/35	B													96	810
28.6	49.00	0.75	241	1.2	0.93	300	28/30/35	B													96	612
23.0	60.90	0.75	299	0.9	0.66	265	28/30/35	B													96	610

\* В монтажной позиции P моторный фланец B5 может не соответствовать размерам. Проверьте размеры и по возможности используйте фланец B14.  
 In the P mounting the B5 motor flange can exceed the foot maximum dimensions. Check on the dimensions and possibly use the flange B14.  
 Der Motoreingangsfansch in B5 kann größer sein als die Getriebefläche. In diesem Falle sollte ein B-14 Flansch genommen werden.  
 Lors d'un montage en forme P la bride peut dépasser des pattes. Vérifier dans les tableaux des dimensions et utiliser si possible une bride B14.  
 En el montaje P la brida puede exceder de las dimensiones máximas de las patas. Verificar en los esquemas dimensionales, asm como la posibilidad de usar la brida B14.

B, C, ...	Возможные моторные фланцы Motor flange available	B	Монтируются с проставкой Coupling by means of reduction bushing		C	Положение отверстий моторного фланца редуктора Motor flange/terminal box position	
-----------	---	---	--	--	---	--	--



**P452A-N**

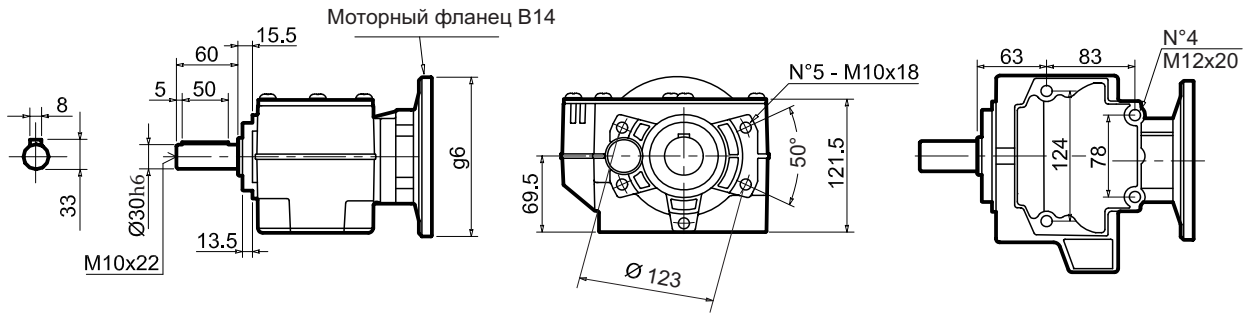

**Выходной фланец / Output flange**

a1 Ø	b1	e1	c1	f1	s1
160	110	130	14	3.5	9 *
200	130	165	13	3.5	11 *
250	180	215	15.5	4	14 *

**P452A-F**

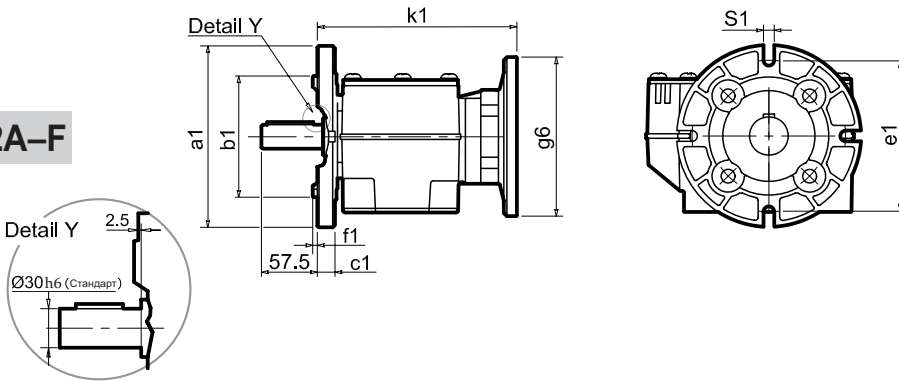

\* Положение отверстий / Holes position

Ø Выходной вал / Output shaft	Стандарт	Ø 30x60
	По запросу	Ø 28x60 Ø 35x60

Масса (кг) с фланцем 8.7  
Масса (кг) с лапами 8.9

**R452A-N**

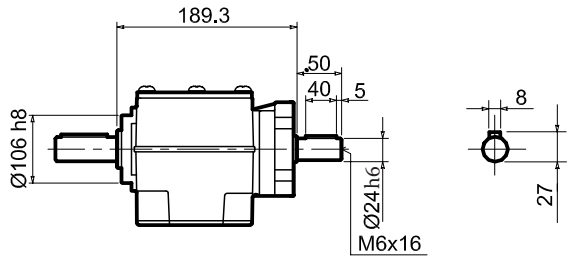

**P452A....**

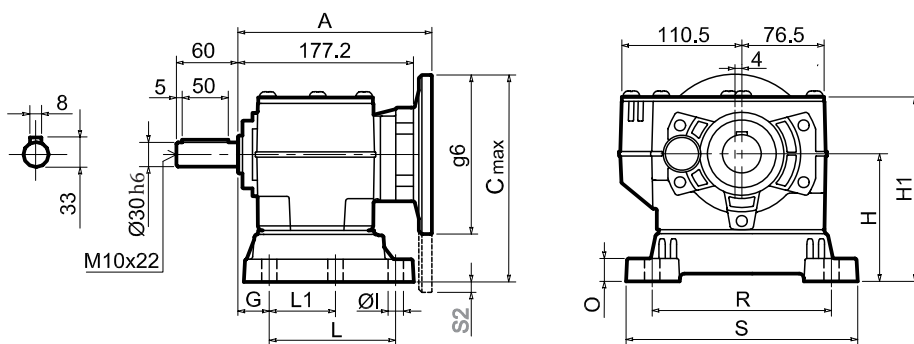

Тип 452A (моторные фланцы)

Моторные фланцы	A	C max	g6	k1
80 B14	195.7	202	120	198.2
90 B14	195.7	212	140	198.2
100 112 B14	206.7	222	160	209.2
71 B5	195.7	222	160	198.2
80/90 B5	197.7	242	200	200.2
100 112 B5	203.7	267	250	206.2

Возможные размеры лап / Available feet dimensions

Market reference	Код лапы	G	H	R	L	S	H 1	O	Ø1	S2 with motor flange	B5 max. flange
302/3	B3	18	110	160	130	190	162	20	11	15 100/112 B5	
30 / 35	B4	20	130	180	149.5	216	182	18	14		
47 - 57	S4	30	115	135	165	170	167	24	13.5		80/90 B5
023 - 233	H 3	30	130	135	135	185	231.5	25	14		
06	L 6	19	125	160	106	205	177	8	14		
2202/3	E 2	13	100	135	192	164	152	6	14		71 B5
52/3	M2	30	110	135+150	100	190	162	18	11	15 100/112 B5	
142	P 4	35	142	130	145	160	194	8	14		80/90 B5
4100-05G	J 3	25	100	150	90	180	152	8	14	25 100/112 B5	

Вы найдете коды в таблицах напротив нужных размеров

Checking the main dimensions (G - H - R - L) you will find the codes (S1 - B1 - etc.) of your need

Наиболее популярные типы / Most popular types



# 320 Nm

# Алюминий

n <sub>2</sub> [min <sup>-1</sup> ]	i	P <sub>1M</sub> [kW]	M <sub>2M</sub> [Nm]	fs	P <sub>1R</sub> [kW]	M <sub>2R</sub> [Nm]		B5					B14					RD	 Код перед. числа		
								B	C	D	E	F	O	P	Q	R	T			U	V
								63	71	80	90	100* 112	56	63	71	80	90			100 112	132

## 502A

n<sub>1</sub> = 1400 min<sup>-1</sup>

388	<b>3.61</b>	5.5	130	1.2	<b>6.3</b>	<b>150</b>	28/30/35	B										96	3018	
331	<b>4.23</b>	5.5	152	1.1	<b>6.1</b>	<b>170</b>	28/30/35	B										96	3016	
279	<b>5.01</b>	5.5	180	1.1	<b>6.1</b>	<b>200</b>	28/30/35	B										96	3014	●
231	<b>6.07</b>	5.5	219	1.1	<b>6.3</b>	<b>250</b>	28/30/35	B										96	3012	
206	<b>6.81</b>	5.5	245	1.2	<b>6.7</b>	<b>300</b>	28/30/35	B										96	2018	
176	<b>7.96</b>	5.5	287	1.2	<b>6.3</b>	<b>330</b>	28/30/35	B										96	2016	
148	<b>9.45</b>	5.5	340	1.0	<b>5.7</b>	<b>354</b>	28/30/35	B										96	2014	●
122	<b>11.43</b>	4	299	1.1	<b>4.4</b>	<b>326</b>	28/30/35	B										96	2012	
99	<b>14.21</b>	3	279	0.9	<b>2.7</b>	<b>250</b>	28/30/35	B										96	2010	
84	<b>16.62</b>	3	327	1.1	<b>3.3</b>	<b>354</b>	28/30/35	B										96	1314	●
70	<b>20.10</b>	2.2	290	1.1	<b>2.5</b>	<b>326</b>	28/30/35	B										96	1312	●
57	<b>24.61</b>	2.2	354	0.9	<b>2.0</b>	<b>326</b>	28/30/35	B										96	1112	
56	<b>24.98</b>	1.5	245	1.0	<b>1.5</b>	<b>250</b>	28/30/35	B										96	1310	●
47.6	<b>29.41</b>	1.5	289	1.2	<b>1.8</b>	<b>354</b>	28/30/35	B										96	814	
39.3	<b>35.58</b>	1.5	349	0.9	<b>1.4</b>	<b>326</b>	28/30/35	B										96	812	
34.6	<b>40.50</b>	1.1	292	1.0	<b>1.1</b>	<b>295</b>	28/30/35	B										96	614	
31.7	<b>44.23</b>	1.1	319	0.8	<b>0.86</b>	<b>250</b>	28/30/35	B										96	810	
28.6	<b>49.00</b>	1.1	353	0.9	<b>1.0</b>	<b>326</b>	28/30/35	B										96	612	
23.0	<b>60.90</b>	0.75	299	0.8	<b>0.63</b>	<b>250</b>	28/30/35	B											610	

## 503A

n<sub>1</sub> = 1400 min<sup>-1</sup>

35.2	<b>39.79</b>	1.1	278	1.3	<b>1.5</b>	<b>373</b>	28/30/35	B					C	C				93	191316	
29.6	<b>47.22</b>	1.1	330	1.1	<b>1.2</b>	<b>354</b>	28/30/35	B					C	C				93	191314	
25.6	<b>54.73</b>	1.1	382	0.9	<b>1.0</b>	<b>354</b>	28/30/35	B					C	C				93	171314	●
21.1	<b>66.22</b>	0.75	315	1.0	<b>0.78</b>	<b>326</b>	28/30/35	B					C	C				93	171312	
18.3	<b>76.69</b>	0.75	365	1.0	<b>0.73</b>	<b>354</b>	28/30/35	B					C	C				93	131314	●
16.7	<b>83.59</b>	0.55	292	1.2	<b>0.67</b>	<b>354</b>	28/30/35	B					C	C				93	190814	
15.1	<b>92.78</b>	0.55	324	1.0	<b>0.55</b>	<b>326</b>	28/30/35	B					C	C				93	131312	
13.4	<b>104.67</b>	0.55	365	1.0	<b>0.53</b>	<b>354</b>	28/30/35	B					C	C				93	101314	●
11.9	<b>117.22</b>	0.37	275	1.2	<b>0.44</b>	<b>326</b>	28/30/35	B					C	C				93	170812	
11.1	<b>126.65</b>	0.37	297	1.1	<b>0.41</b>	<b>326</b>	28/30/35	B					C	C				93	101312	
10.2	<b>136.62</b>	0.37	321	1.1	<b>0.41</b>	<b>354</b>	28/30/35	B					C	C				93	91314	●
8.5	<b>165.29</b>	0.25	262	1.2	<b>0.31</b>	<b>326</b>	28/30/35	B					C	C				93	91312	
7.8	<b>180.40</b>	0.25	286	1.2	<b>0.31</b>	<b>354</b>	28/30/35	B					C	C				93	71314	●
6.4	<b>218.26</b>	0.25	346	0.9	<b>0.24</b>	<b>326</b>	28/30/35	B					C	C				93	71312	
5.8	<b>241.82</b>	0.25	384	0.9	<b>0.23</b>	<b>354</b>	28/30/35	B					C	C				93	90814	●
4.8	<b>292.57</b>	0.18	334	1.0	<b>0.18</b>	<b>326</b>	28/30/35	B					C	C				93	90812	
4.4	<b>319.32</b>	0.18	365	1.0	<b>0.17</b>	<b>354</b>	28/30/35	B					C	C				93	70814	
3.6	<b>386.33</b>	0.18	441	0.7	<b>0.13</b>	<b>326</b>	28/30/35	B					C	C				93	70812	●
2.9	<b>480.16</b>	0.18	548	0.5	<b>0.08</b>	<b>250</b>	28/30/35	B					C	C				93	70810	

\* В монтажной позиции P моторный фланец B5 может не соответствовать размерам. Проверьте размеры и по возможности используйте фланец B14.  
 In the P mounting the B5 motor flange can exceed the foot maximum dimensions. Check on the dimensions and possibly use the flange B14.  
 Der Motoreingangsflansch in B5 kann größer sein als die Getriebeßaße. In diesem Falle sollte ein B-14 Flansch genommen werden.  
 Lors d'un montage en forme P la bride peut dépasser des pattes. Vérifier dans les tableaux des dimensions et utiliser si possible une bride B14.  
 En el montaje P la brida puede exceder de las dimensiones máximas de las patas. Verificar en los esquemas dimensionales, asm como la posibilidad de usar la brida B14.

B, C, ...	Возможные моторные фланцы Motor flange available	B	Монтируются с проставкой Coupling by means of reduction bushing		C	Положение отверстий моторного фланца редуктора Motor flange/terminal box position	
-----------	---	---	--	--	---	--	--



	502A	503A
X	5.3	15

502A	503A
------	------

Масса (кг) с фланцем 11.7 11.9  
Масса (кг) с лапами 11.9 12.1

P502A-N  
P503A-N

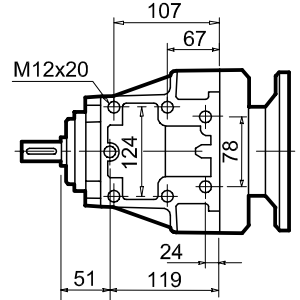
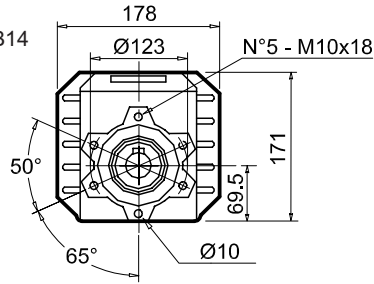
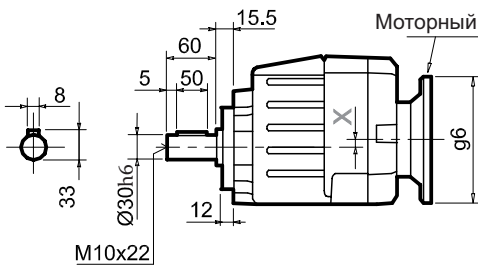

P502A-F  
P503A-F

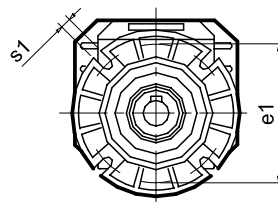
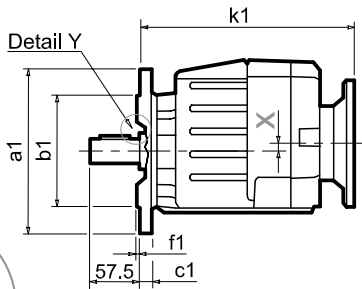

Выходной фланец / Output flange

a1 Ø	b1	e1	c1	f1	s1
160	110	130	14	3.5	9
200	130	165	13	3.5	11
250	180	215	15.5	4	14

ØВыходной вал / Output shaft  
Стандарт Ø 30x60  
По запросу Ø 28x60 Ø 35x60

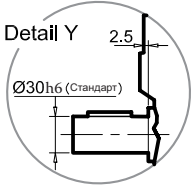

R502A-N  
R503A-N

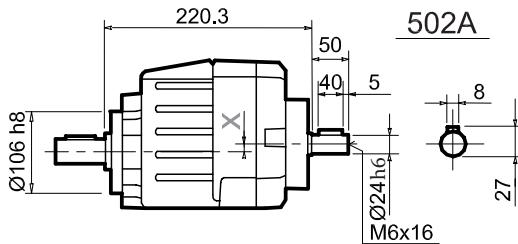

502A

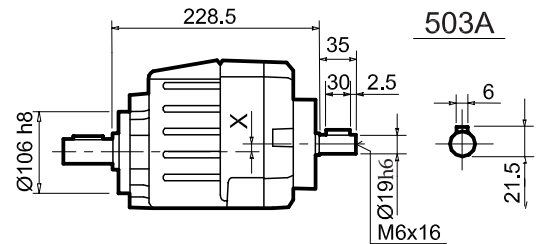

503A

P502A....  
P503A....

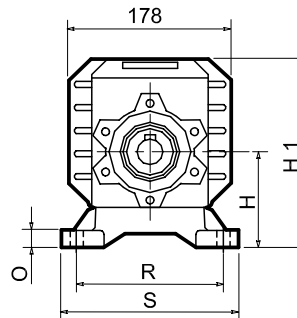
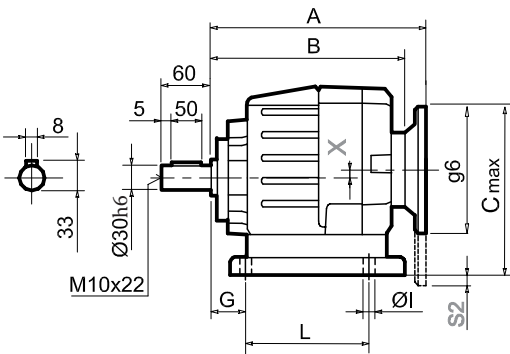

Тип 502A (моторные фланцы)

Моторные фланцы	A	B	C max	g6	k1
80 B14	226	207.5	207.3	120	228.5
90 B14	226		217.3	140	228.5
100 112 B14	237		227.3	160	243.2
71 B5	226	216	227.3	160	228.5
80/90 B5	228		247.3	200	230.5
100 112 B5	234		272.3	250	236.5
132 B14	255.5	216	247	200	264

Тип 503A (моторные фланцы)

Моторные фланцы	A	B	C max	g6	k1
71 B14	234.5	216	209.5	105	237
80 B14	235.5		217	120	238
90 B14	236.5		227	140	239
63 B5	236.5	216	227	140	239
71 B5	234.5		237	160	237
80/90 B5	236.5		257	200	239

Возможные размеры лап / Available feet dimensions

Market reference	Код лапы	G	H	R	L	S	H 1	O	ØI	ØI	S2 With motor flange	B5 max. flange
302/3	B3	18	110	160	130	190	211.5	20	11	10	100/112 B5	
30 / 35	B4	20	130	180	149.5	216	231.5	18	14			
47 - 57	S4	30	115	135	165	170	216.5	24	13.5	5	100/112 B5	
023 - 233	H 3	30	130	135	135	185	231.5	25	14			
06	L 6	19	125	160	106	205	226.5	8	14			
2202/3	E 2	13	100	135	192	164	201.5	6	14			80/90 B5
52/3	M2	30	110	135-150	100	190	211.5	18	11	10	100/112 B5	
142	P 4	35	142	130	145	160	243.5	8	14			
4100-05G	J 3	25	100	150	90	180	201.5	8	14	20	100/112 B5	

Вы найдете коды в таблицах напротив нужных размеров

Checking the main dimensions (G - H - R - L) you will find the codes (S1 - B1 - etc.) of your need

Наиболее популярные типы / Most popular types





# 460 Nm

# Алюминий

n <sub>2</sub> [min <sup>-1</sup> ]	i	P <sub>1M</sub> [kW]	M <sub>2M</sub> [Nm]	fs	P <sub>1R</sub> [kW]	M <sub>2R</sub> [Nm]		B5					B14					RD	 Код перед. числа		
								B	C	D	E	F	O	P	Q	R	T			U	V
								63	71	80	90	100 112	56	63	71	80	90			100 112	132

## 602A

n<sub>1</sub> = 1400 min<sup>-1</sup>

388	<b>3.61</b>	7.5	177	0.9	<b>7.0</b>	<b>165</b>	30/35/40	B										96	3018	
331	<b>4.23</b>	7.5	208	1.0	<b>7.2</b>	<b>200</b>	30/35/40	B										96	3016	
279	<b>5.01</b>	7.5	246	1.0	<b>7.3</b>	<b>240</b>	30/35/40	B										96	3014	●
231	<b>6.07</b>	7.5	298	0.9	<b>6.8</b>	<b>270</b>	30/35/40	B										96	3012	
206	<b>6.81</b>	5.5	245	1.4	<b>7.6</b>	<b>340</b>	30/35/40	B										96	2018	
176	<b>7.96</b>	5.5	287	1.3	<b>7.1</b>	<b>370</b>	30/35/40	B										96	2016	
148	<b>9.45</b>	5.5	340	1.2	<b>6.5</b>	<b>400</b>	30/35/40	B										96	2014	●
122	<b>11.43</b>	5.5	412	1.0	<b>5.3</b>	<b>400</b>	30/35/40	B										96	2012	
99	<b>14.21</b>	4	372	1.1	<b>4.3</b>	<b>400</b>	30/35/40	B										96	2010	
84	<b>16.62</b>	4	435	1.2	<b>4.6</b>	<b>501</b>	30/35/40	B										96	1314	●
70	<b>20.10</b>	4	527	0.9	<b>3.8</b>	<b>499</b>	30/35/40	B										96	1112	●
57	<b>24.61</b>	3	483	1.0	<b>3.1</b>	<b>492</b>	30/35/40	B										96	1312	●
56	<b>24.98</b>	3	491	0.8	<b>2.4</b>	<b>400</b>	30/35/40	B										96	1310	
47.6	<b>29.41</b>	2.2	424	1.0	<b>2.3</b>	<b>440</b>	30/35/40	B										96	814	
39.3	<b>35.58</b>	1.85	431	1.2	<b>2.1</b>	<b>499</b>	30/35/40	B										96	812	
34.6	<b>40.50</b>	1.1	292	1.1	<b>1.2</b>	<b>310</b>	30/35/40	B										96	614	
31.7	<b>44.23</b>	1.5	434	0.9	<b>1.4</b>	<b>400</b>	30/35/40	B										96	810	
28.6	<b>49.00</b>	1.1	353	1.0	<b>1.1</b>	<b>368</b>	30/35/40	B										96	612	
23.0	<b>60.90</b>	1.1	439	0.9	<b>1.0</b>	<b>400</b>	30/35/40	B										96	610	

## 603A

n<sub>1</sub> = 1400 min<sup>-1</sup>

35.2	<b>39.79</b>	1.5	379	1.1	<b>1.7</b>	<b>434</b>	30/35/40	B										C	C		93	191316		
29.6	<b>47.22</b>	1.5	449	1.1	<b>1.7</b>	<b>501</b>	30/35/40	B											C	C		93	191314	
25.6	<b>54.73</b>	1.5	521	1.0	<b>1.4</b>	<b>501</b>	30/35/40	B											C	C		93	171314	●
24.5	<b>57.13</b>	1.1	399	1.3	<b>1.4</b>	<b>500</b>	30/35/40	B											C	C		93	191312	
21.1	<b>66.22</b>	1.1	462	1.1	<b>1.2</b>	<b>500</b>	30/35/40	B											C	C		93	171312	
19.7	<b>71.01</b>	1.1	496	0.9	<b>0.97</b>	<b>435</b>	30/35/40	B											C	C		93	191310	
18.3	<b>76.69</b>	1.1	535	0.9	<b>1.0</b>	<b>501</b>	30/35/40	B											C	C		93	131314	●
17.0	<b>82.30</b>	0.75	392	1.1	<b>0.83</b>	<b>435</b>	30/35/40	B											C	C		93	171310	
16.7	<b>83.59</b>	0.75	398	1.1	<b>0.83</b>	<b>441</b>	30/35/40	B											C	C		93	190814	
15.1	<b>92.78</b>	0.75	441	1.1	<b>0.85</b>	<b>500</b>	30/35/40	B											C	C		93	131312	
13.4	<b>104.68</b>	0.75	498	1.0	<b>0.75</b>	<b>501</b>	30/35/40	B											C	C		93	101314	●
11.9	<b>117.22</b>	0.55	409	1.2	<b>0.67</b>	<b>500</b>	30/35/40	B											C	C		93	170812	
11.1	<b>126.65</b>	0.55	442	1.1	<b>0.62</b>	<b>500</b>	30/35/40	B											C	C		93	101312	●
10.3	<b>135.74</b>	0.37	319	1.4	<b>0.51</b>	<b>441</b>	30/35/40	B											C	C		93	130814	
9.6	<b>145.68</b>	0.37	342	1.3	<b>0.47</b>	<b>435</b>	30/35/40	B											C	C		93	170810	
8.9	<b>157.40</b>	0.37	369	1.2	<b>0.44</b>	<b>435</b>	30/35/40	B											C	C		93	101310	
8.5	<b>165.29</b>	0.37	388	1.3	<b>0.48</b>	<b>500</b>	30/35/40	B											C	C		93	91312	●
7.6	<b>185.29</b>	0.37	435	1.0	<b>0.38</b>	<b>441</b>	30/35/40	B											C	C		93	100814	
6.8	<b>205.43</b>	0.37	482	0.9	<b>0.33</b>	<b>435</b>	30/35/40	B											C	C		93	91310	
6.2	<b>224.18</b>	0.37	526	1.0	<b>0.35</b>	<b>500</b>	30/35/40	B											C	C		93	100812	
5.8	<b>241.82</b>	0.25	384	1.1	<b>0.29</b>	<b>441</b>	30/35/40	B											C	C		93	90814	●
5.0	<b>278.62</b>	0.25	442	1.0	<b>0.25</b>	<b>435</b>	30/35/40	B											C	C		93	100810	
4.8	<b>292.57</b>	0.25	464	1.1	<b>0.27</b>	<b>500</b>	30/35/40	B											C	C		93	90812	●
3.9	<b>363.63</b>	0.18	415	1.0	<b>0.19</b>	<b>435</b>	30/35/40	B											C	C		93	90810	

B, C, ...

Возможные моторные фланцы  
Motor flange available

B

Монтируются с проставкой  
Coupling by means of reduction bushing



C

Положение отверстий в моторном  
фланце редуктора  
Motor flange/terminal box position





	602A	603A
X	21.8	15.5

602A	603A
------	------

Масса (кг) с фланцем 14.1 14.3  
Масса (кг) с лапами 14.5 14.7

P602A-N  
P603A-N

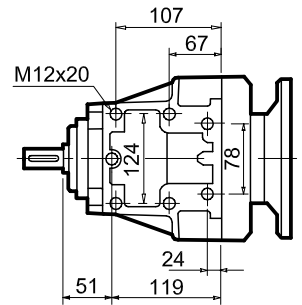
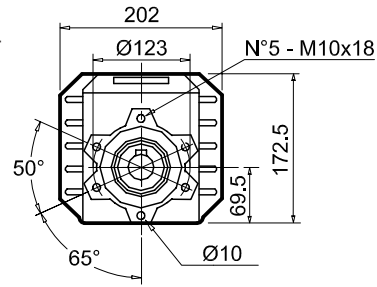
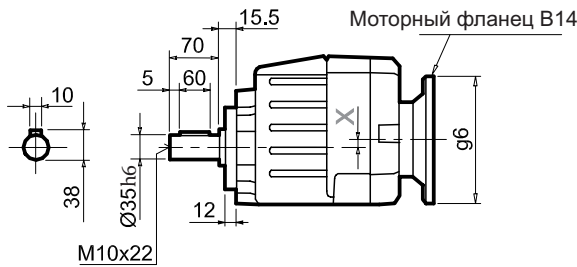

P602A-F  
P603A-F

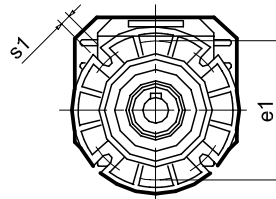
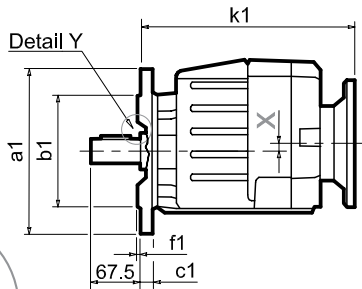

Выходной фланец / Output flange

a1 Ø	b1	e1	c1	f1	s1
160	110	130	14	3.5	9
200	130	165	13	3.5	11
250	180	215	15.5	4	14

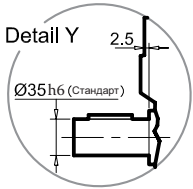

Стандарт	Ø 35x70
По запросу	Ø 30x60 Ø 38x70
On request	Ø 40x80

R602A-N  
R603A-N

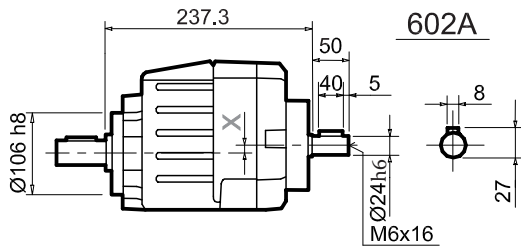

602A

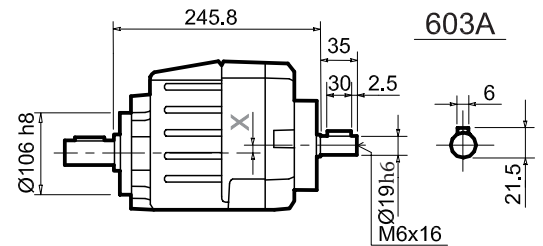

603A

P602A....  
P603A....

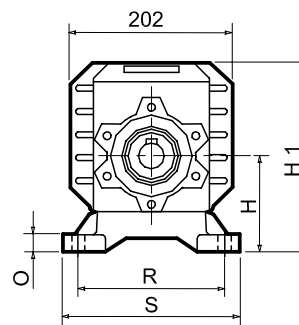
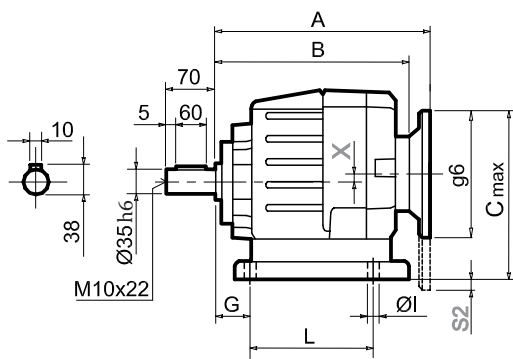

Тип 602A (моторные фланцы)

Моторные фланцы	A	B	C max	g6	k1
80 B14	243.8	225.3	243.8	120	246.3
90 B14	243.8		253.8	140	246.3
<sup>100</sup> 112 B14	254.8	225.3	263.8	160	261
132 B14	273		283.8	200	282
71 B5	243.8	225.3	263.8	160	246.3
80/90 B5	245.8		283.8	200	248.3
<sup>100</sup> 112 B5	251.8	225.3	308.8	250	254.3

Тип 603A (моторные фланцы)

Моторные фланцы	A	B	C max	g6	k1
71 B14	253	234.5	230	105	255.5
80 B14	254		237.5	120	256.5
90 B14	255	234.5	247.5	140	257.5
63 B5	255		247.5	140	257.5
71 B5	253	234.5	257.5	160	255.5
80/90 B5	255		277.5	200	257.5

Возможные размеры лап / Available feet dimensions

Market reference	Код лапы	G	H	R	L	S	H1	O	Ø	S2 With motor flange	B5 max. flange
402/3	B4	20	130	180	149.5	216	233	18	14	-	100 112 B5
47 - 57	S4	30	115	135	165	170	218	24	13.5	-	
77	S7	35	140	170	205	204	243	8	14	-	
024 - 243	H4	35	155	170	150	225	258	30	14	-	
06	L6	19	125	160	106	205	228	8	14	-	
2302/3	E3	19.5	125	170	240	205	228	8	14	-	
62/3	M3	35	120	170-185	110	230	223	20	14	-	
162	P6	40	162	160	205	200	265	8	14	-	
4110G	J4	27	120	190	115	225	223	8	14	-	

Вы найдете коды в таблицах напротив нужных размеров

Checking the main dimensions (G - H - R - L) you will find the codes (S1 - B1 - etc.) of your need.

Наиболее популярные типы  
Most popular types



# 460 Nm

# Чугун

$n_2$ [min <sup>-1</sup> ]	i	P <sub>1M</sub> [kW]	M <sub>2M</sub> [Nm]	fs	P <sub>1R</sub> [kW]	M <sub>2R</sub> [Nm]		B5					B14					RD	 Код перед. числа		
								B	C	D	E	F	O	P	Q	R	T			U	V
								63	71	80	90	100 112	56	63	71	80	90			100 112	132

## 602C

$n_1 = 1400 \text{ min}^{-1}$

388	<b>3.61</b>	7.5	177	0.9	7.0	165	30/35/40	B										96	3018		
331	<b>4.23</b>	7.5	208	1.0	7.2	200	30/35/40	B											96	3016	
279	<b>5.01</b>	7.5	246	1.0	7.3	240	30/35/40	B											96	3014	●
231	<b>6.07</b>	7.5	298	0.9	6.8	270	30/35/40	B											96	3012	
206	<b>6.81</b>	5.5	245	1.4	7.6	340	30/35/40	B											96	2018	
176	<b>7.96</b>	5.5	287	1.3	7.1	370	30/35/40	B											96	2016	
148	<b>9.45</b>	5.5	340	1.2	6.5	400	30/35/40	B											96	2014	●
122	<b>11.43</b>	5.5	412	1.0	5.3	400	30/35/40	B											96	2012	
99	<b>14.21</b>	4	372	1.2	4.7	435	30/35/40	B											96	2010	
84	<b>16.62</b>	4	435	1.2	4.6	501	30/35/40	B											96	1314	●
70	<b>20.10</b>	4	527	0.9	3.8	499	30/35/40	B											96	1312	●
56	<b>24.98</b>	3	491	0.9	2.7	435	30/35/40	B											96	1310	●
47.6	<b>29.41</b>	2.2	424	1.0	2.3	440	30/35/40	B											96	0814	
39.3	<b>35.58</b>	1.85	431	1.2	2.1	499	30/35/40	B											96	0812	
34.6	<b>40.50</b>	1.1	292	1.1	1.2	310	30/35/40	B											96	0614	
31.7	<b>44.23</b>	1.5	434	1.0	1.5	435	30/35/40	B											96	0810	
28.6	<b>49.00</b>	1.1	353	1.0	1.1	368	30/35/40	B											96	0612	
23.0	<b>60.90</b>	1.1	439	1.0	1.1	435	30/35/40	B											96	0610	

## 603C

$n_1 = 1400 \text{ min}^{-1}$

35.2	<b>39.79</b>	1.5	379	1.1	1.7	434	30/35/40	B											93	191318		
29.6	<b>47.22</b>	1.5	449	1.1	1.7	501	30/35/40	B												93	191316	
25.6	<b>54.73</b>	1.5	521	1.0	1.4	501	30/35/40	B												93	191314	●
24.5	<b>57.13</b>	1.1	399	1.3	1.4	500	30/35/40	B												93	171314	
21.1	<b>66.22</b>	1.1	462	1.1	1.2	500	30/35/40	B												93	191312	
19.7	<b>71.01</b>	1.1	496	0.9	0.97	435	30/35/40	B												93	171312	
18.3	<b>76.69</b>	1.1	535	0.9	1.0	501	30/35/40	B												93	191310	●
17.0	<b>82.30</b>	0.75	392	1.1	0.83	435	30/35/40	B												93	131314	
16.7	<b>83.59</b>	0.75	398	1.1	0.83	441	30/35/40	B												93	171310	
15.1	<b>92.78</b>	0.75	441	1.1	0.85	500	30/35/40	B												93	190814	●
13.4	<b>104.68</b>	0.75	498	1.0	0.75	501	30/35/40	B												93	131312	
11.9	<b>117.22</b>	0.55	409	1.2	0.67	500	30/35/40	B												93	101314	
11.1	<b>126.65</b>	0.55	442	1.1	0.62	500	30/35/40	B												93	170812	●
10.3	<b>135.74</b>	0.37	319	1.4	0.51	441	30/35/40	B												93	101312	
9.6	<b>145.68</b>	0.37	342	1.3	0.47	435	30/35/40	B												93	130814	
8.9	<b>157.40</b>	0.37	369	1.2	0.44	435	30/35/40	B												93	170810	●
8.5	<b>164.23</b>	0.37	385	1.3	0.48	500	30/35/40	B												93	101310	
7.6	<b>185.29</b>	0.37	435	1.0	0.38	441	30/35/40	B												93	130812	
6.9	<b>204.16</b>	0.37	479	0.9	0.34	435	30/35/40	B												93	100814	
6.2	<b>224.18</b>	0.37	526	1.0	0.35	500	30/35/40	B												93	130810	
5.0	<b>278.62</b>	0.25	442	1.0	0.25	435	30/35/40	B												93	100812	

B, C, ...

Возможные фланцы  
Motor flange available

B

Монтируется с проставкой  
Coupling by means of reduction bushing



C

Положение отверстий моторного  
фланца редуктора  
Motor flange/terminal box position





P602C-N  
P603C-N

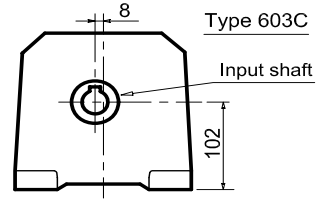
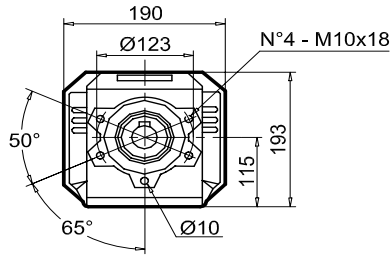
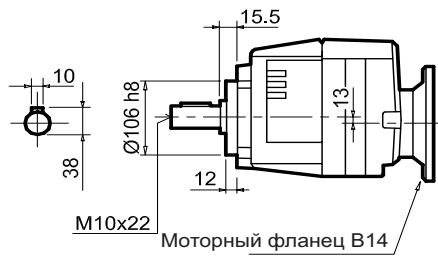

602C 603C

Масса (кг) с фланцем 21.4 21.2  
Масса (кг) с лапами 21.3 21.1

P602C-F  
P603C-F

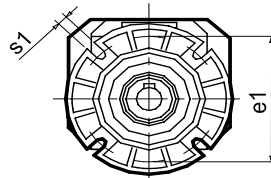
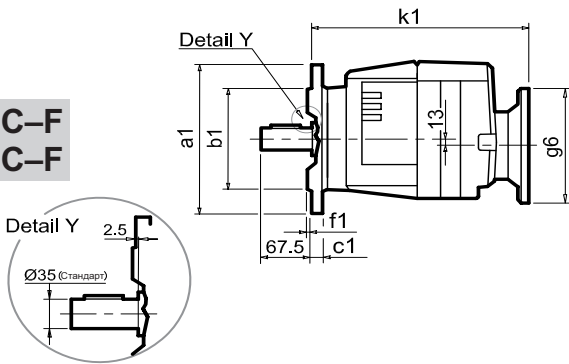

Выходной фланец / Output flange

a1 Ø	b1	e1	c1	f1	s1
160	110	130	14	3.5	9
200	130	165	13	3.5	11
250	180	215	15.5	4	14

Ø Выходной вал / Output shaft  
Стандарт Ø 35x70  
По запросу / On request Ø 30x60 Ø 38x70 Ø 40x80

R602CSP  
R603CSP

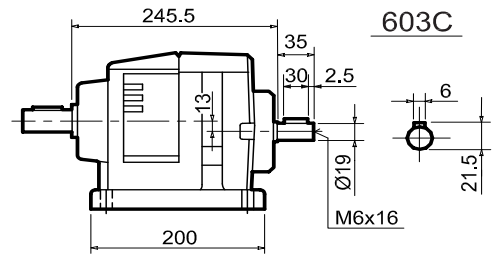
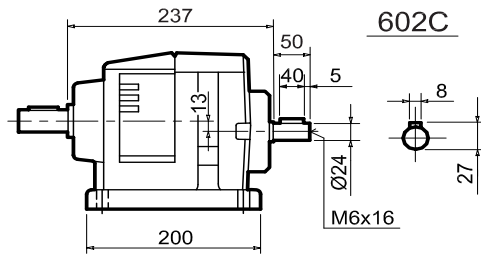

P602CSP  
P603CSP

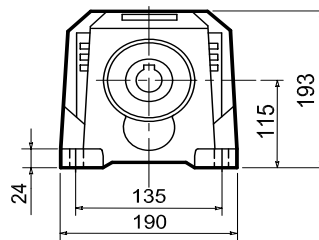
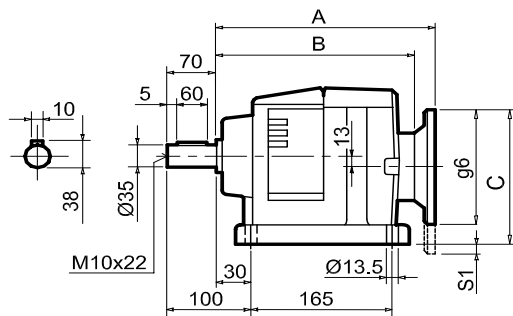

Тип 602A (моторные фланцы)

Моторные фланцы	A	B	C	g6	S1	k1
80 B14	243.8	225.3	162	120		246
90 B14	243.8		172	140		246
100 B14	254.8		182	160		260.7
132 B14	273		215	200		282
71 B5	243.8		182	160		246
80/90 B5	245.8		202	200		248
100 B5	251.8		227	250	23	254

Тип 603A (моторные фланцы)

Motor Flange	A	B	C	g6	S1	k1
71 B14	252.5	234	156	105		275.5
80 B14	253.5		162	120		276.5
90 B14	254.5		172	140		277.5
63 B5	254.5		172	140		277.5
71 B5	252.5		182	160		275.5
80/90 B5	254.5		202	200		277.5



# ВЫБОР МОТОР-РЕДУКТОРОВ / GEARMOTORS SELECTION / WAHL DES GETRIEBEMOTORS SELECTION DES MOTO-REDUCTEURS / SELECCIYN MOTO-REDUCTORES

Как выбрать мотор-редуктор / How to select a motorized gearbox / Wie wdhlt man einen Getriebemotor  
Comment sйlectionner un moto-rйducteur / Cыmo seleccionar un moto-reductores

B		C		A		E		D		D2		D1	
Скорость на тихоходном валу Rotation speed Abtriebsdrehzahl Vitesse de rotation		Крутящий момент на валу Torque moment Drehmoment Moment de torsion Par torsion		Мощность двигателя Service factor Betriebsfaktor Facteur de service Factor de servicio		Фланец IEC IEC Flange IEC Flansch Bride CEI Bridas IEC		Корпус (алюминий) Aluminium gearbox Aluminiumgetriebe Rйducteur en aluminium Reductor en aluminio		Двигатель IEC IEC motor code Motor code IEC Code moteur IEC Cydigo motor IEC		Корпус (чугун) Cast iron gearbox Graugussgetriebe Rйducteur en fonte Reductor en hierro fundido	
n <sub>2</sub> [min <sup>-1</sup> ]		M <sub>2</sub> [Nm]		P <sub>1M</sub> = 0.37 kW		1400 min <sup>-1</sup> (71B4)		D		D2		D1	
i		fs		fs		fs		D		D2		D1	
n <sub>1</sub> = 1400 (2800, 900) min <sup>-1</sup>													
9.6	342	145.68	1.3	30/35/40	603A	603C	71B4	63 <sup>B1</sup> -71-80-90	71 <sup>C1</sup> -80 <sup>C1</sup> -90				35
9.6	342	145.68	1.3	30/35/40	603A	603C	71B4	63 <sup>B1</sup> -71-80-90	71 <sup>C1</sup> -80 <sup>C1</sup> -90				37
10.2	321	136.62	1.1	28/30/35	503A	603C	71B4	63 <sup>B1</sup> -71-80-90	71 <sup>C1</sup> -80 <sup>C1</sup> -90				33
10.3	319	135.74	1.4	30/35/40	603A	603C	71B4	63 <sup>B1</sup> -71-80-90	71 <sup>C1</sup> -80 <sup>C1</sup> -90				35
10.3	319	135.74	1.4	30/35/40	603A	603C	71B4	63 <sup>B1</sup> -71-80-90	71 <sup>C1</sup> -80 <sup>C1</sup> -90				37

E	1)	2)	3)
Доступные моторные фланцы Motor flange available Erhдltliche Motorflansche Brides disponibles Bridas disponibles	Чтобы проверить совместимость определенных лап с двигателем типа B5, смотрите страницу размеров. В случае необходимости используйте двигатель типа B14. To verify the applicability of the B5 motors with the specific feet, check on dimensions page and use a B14 Motor Die Durchmesser der B5 Eingangsfalnsche hinsichtlich der Hйhe der Getriebefуe sollte mittels MaЯblatt geprфt werden. Gegebenenfalls ist ein B14 Flansch-Motor einzusetzen. Pour la faisabilitй du montage de ces tailles moteurs, voir la page des dimensions et monter si possible un moteur B14 Para verificar la posibilidad de montaje de motores con estas dimensiones en la version patas, comprobar en la pagina de dimensiones, asm como la posibilidad de usar la brida B14	Монтируется с проставкой / Coupling by means of reduction bushing Reduzierhуsen / Montage avec douille de rйduction / Montaje con casquillo de reducciyn	Положение отверстий моторного фланца редуктора / Motor flange/terminal box position Bohrungsposition am Motorflansch/-sockel / Position trous bride/barrette a bornes moteur Pосиcиn agujeros brida / base motor

A	B	C	D, D1	D2	E
Выберите мощность	Выберите скорость на тихоходном валу	Выберите требуемый крутящий момент в соответствии с сервис-фактором	Выберите требуемый редуктор (алюминиевый или чугунный корпус)	На одной линии с выбранным редуктором Вы найдете требуемый двигатель (напр. 63A6 значит высота оси двигателя 63 мм, 6-полюсный)	Смотрите доступные фланцы
Select power	Select power speed	Select required torque according to service factor	Select the required motorization (gearbox with cast iron or aluminium housing)	On the same line of selected motorization, you can find relevant motor type (i.e. 63B6 where 63 correspond to motorsize, 6 is the poles number at 6 pole and 4 is the poles number at 4 pole (63A4))	See motor flange available
Ausgewдhlte Leistung	Ausgewдhlte Abtriebsdrehzahl	Ausgewдhltes Drehmoment in Bezug zum Betriebsfaktor	Wdhlen Sie die gewдnschte Motorisierung (Untersetzungsgetriebe mit Aluminium- oder GuЯeisengehуse)	Auf der gleichen Linie wie der ausgewдhlte Getriebe-motor ist die entsprechende Motorgrуe zu finden. (z.B. 63B6 = BG 63, 6-polig oder 63A4= BG 63, 4-polig)	Erhдltliche Motorflansche
Sйlectionne la puissance	Sйlectionne la vitesse en sortie	Sйlectionne le couple sur la base du facteur de service fs souhaitй	Choisissez la motorisation que vous souhaitez (rйducteur avec caisse en aluminium ou en fonte)	Sur la ligne correspondante a la motorisation prй-choisie on peut relever le type de moteur (ex. 63B6 la оц 63 est la grandeur moteur, 6 est la polaritй 6 pйles et 4 est la polaritй 4 pйles)	Choisir la bride disponible
Seleccionar la potencia	Seleccionar la velocidad de salida	Seleccionar el par de torsiyn en funciyn del factor de servicio fs deseado	Seleccionar la motorizaciyn deseada (reductor con carcasa de aluminio o de hierro fundido)	En la lnea correspondiente al motor preseleccionado puede encontrar el tipo de motor (ej. 63B6, donde 63 nos indica el tamaco del motor, 6 es la polaridad 6 polos y 4 la polaridad 4 polos)	Seleccionar la brida disponible





**P<sub>1M</sub> = 0.09 kW**

1400 min<sup>-1</sup> (56B4) - 900 min<sup>-1</sup> (63A6)

n <sub>2</sub> [min <sup>-1</sup> ]	M <sub>2</sub> [Nm]	i	fs								
								B5	B14		
2.5	323	<b>363.63</b>	1.3	30/35/40		<b>603A</b>	<b>63A6</b>	63 <sup>B</sup> -71-80-90	71 <sup>C</sup> -80 <sup>C</sup> -90		35
3.1	260	<b>292.57</b>	1.3	28/30/35		<b>503A</b>	<b>63A6</b>	63 <sup>B</sup> -71-80-90	71 <sup>C</sup> -80 <sup>C</sup> -90		33
5.1	157	<b>177.09</b>	1.0	24/25		<b>403A</b>	<b>63A6</b>	63-71	56 <sup>B</sup> <sup>C</sup> -63 <sup>C</sup> -71	●	27
6.5	123	<b>216.00</b>	1.1	24/25		<b>403A</b>	<b>56B4</b>	63-71	56 <sup>B</sup> <sup>C</sup> -63 <sup>C</sup> -71		27
6.6	121	<b>135.69</b>	1.3	24/25		<b>403A</b>	<b>63A6</b>	63-71	56 <sup>B</sup> <sup>C</sup> -63 <sup>C</sup> -71	●	27
7.1	112	<b>126.40</b>	1.4	24/25		<b>403A</b>	<b>63A6</b>	63-71	56 <sup>B</sup> <sup>C</sup> -63 <sup>C</sup> -71	●	27
7.9	101	<b>177.09</b>	1.6	24/25		<b>403A</b>	<b>56B4</b>	63-71	56 <sup>B</sup> <sup>C</sup> -63 <sup>C</sup> -71	●	27
8.5	94	<b>165.20</b>	1.5	24/25		<b>403A</b>	<b>56B4</b>	63-71	56 <sup>B</sup> <sup>C</sup> -63 <sup>C</sup> -71		27
10.3	77	<b>135.69</b>	2.1	24/25		<b>403A</b>	<b>56B4</b>	63-71	56 <sup>B</sup> <sup>C</sup> -63 <sup>C</sup> -71	●	27
11.1	72	<b>126.40</b>	2.2	24/25		<b>403A</b>	<b>56B4</b>	63-71	56 <sup>B</sup> <sup>C</sup> -63 <sup>C</sup> -71	●	27
14.5	55	<b>96.85</b>	2.9	24/25		<b>403A</b>	<b>56B4</b>	63-71	56 <sup>B</sup> <sup>C</sup> -63 <sup>C</sup> -71	●	27
14.5	57	<b>61.89</b>	1.2	14/16		<b>202A</b>	<b>63A6</b>	63-71	56 <sup>B</sup> <sup>C</sup> -63 <sup>C</sup> -71		23
16.2	50	<b>86.66</b>	2.8	24/25		<b>403A</b>	<b>56B4</b>	63-71	56 <sup>B</sup> <sup>C</sup> -63 <sup>C</sup> -71		27
18.1	46	<b>49.76</b>	1.5	14/16		<b>202A</b>	<b>63A6</b>	63-71	56 <sup>B</sup> <sup>C</sup> -63 <sup>C</sup> -71	●	23
22.6	36	<b>61.89</b>	1.9	14/16		<b>202A</b>	<b>56B4</b>	63-71	56 <sup>B</sup> <sup>C</sup> -63 <sup>C</sup> -71		23
28.1	29	<b>49.76</b>	2.4	14/16		<b>202A</b>	<b>56B4</b>	63-71	56 <sup>B</sup> <sup>C</sup> -63 <sup>C</sup> -71	●	23
29.9	28	<b>46.87</b>	2.5	14/16		<b>202A</b>	<b>56B4</b>	63-71	56 <sup>B</sup> <sup>C</sup> -63 <sup>C</sup> -71		23
37.1	22	<b>37.69</b>	3.2	14/16		<b>202A</b>	<b>56B4</b>	63-71	56 <sup>B</sup> <sup>C</sup> -63 <sup>C</sup> -71	●	23
39.0	21	<b>35.91</b>	3.3	14/16		<b>202A</b>	<b>56B4</b>	63-71	56 <sup>B</sup> <sup>C</sup> -63 <sup>C</sup> -71		23
48.5	17	<b>28.88</b>	4.1	14/16		<b>202A</b>	<b>56B4</b>	63-71	56 <sup>B</sup> <sup>C</sup> -63 <sup>C</sup> -71	●	23
53	16	<b>26.31</b>	3.9	14/16		<b>202A</b>	<b>56B4</b>	63-71	56 <sup>B</sup> <sup>C</sup> -63 <sup>C</sup> -71		23
64	13	<b>21.84</b>	4.7	14/16		<b>202A</b>	<b>56B4</b>	63-71	56 <sup>B</sup> <sup>C</sup> -63 <sup>C</sup> -71		23
66	12	<b>21.15</b>	4.8	14/16		<b>202A</b>	<b>56B4</b>	63-71	56 <sup>B</sup> <sup>C</sup> -63 <sup>C</sup> -71	●	23
75	11	<b>18.78</b>	5.4	14/16		<b>202A</b>	<b>56B4</b>	63-71	56 <sup>B</sup> <sup>C</sup> -63 <sup>C</sup> -71		23
86	10	<b>16.20</b>	6.3	14/16		<b>202A</b>	<b>56B4</b>	63-71	56 <sup>B</sup> <sup>C</sup> -63 <sup>C</sup> -71		23
93	9	<b>15.10</b>	6.7	14/16		<b>202A</b>	<b>56B4</b>	63-71	56 <sup>B</sup> <sup>C</sup> -63 <sup>C</sup> -71	●	23
107	8	<b>13.03</b>	7.8	14/16		<b>202A</b>	<b>56B4</b>	63-71	56 <sup>B</sup> <sup>C</sup> -63 <sup>C</sup> -71		23
123	7	<b>11.42</b>	8.9	14/16		<b>202A</b>	<b>56B4</b>	63-71	56 <sup>B</sup> <sup>C</sup> -63 <sup>C</sup> -71		23

**P<sub>1M</sub> = 0.13 kW**

n<sub>1</sub> = 1400 min<sup>-1</sup> (63A4)

3.6	319	<b>386.33</b>	1.0	28/30/35		<b>503A</b>	<b>63A4</b>	63 <sup>B</sup> -71-80-90	71 <sup>C</sup> -80 <sup>C</sup> -90		33	
3.9	300	<b>363.63</b>	1.5	30/35/40		<b>603A</b>	<b>63A4</b>	63 <sup>B</sup> -71-80-90	71 <sup>C</sup> -80 <sup>C</sup> -90		35	
4.4	263	<b>319.32</b>	1.3	28/30/35		<b>503A</b>	<b>63A4</b>	63 <sup>B</sup> -71-80-90	71 <sup>C</sup> -80 <sup>C</sup> -90	●	33	
4.8	241	<b>292.57</b>	1.4	28/30/35		<b>503A</b>	<b>63A4</b>	63 <sup>B</sup> -71-80-90	71 <sup>C</sup> -80 <sup>C</sup> -90		33	
4.8	241	<b>292.57</b>	2.1	30/35/40		<b>603A</b>	<b>63A4</b>	63 <sup>B</sup> -71-80-90	71 <sup>C</sup> -80 <sup>C</sup> -90	●	35	
5.0	230	<b>278.62</b>	1.9	30/35/40		<b>603A</b>	<b>63A4</b>	63 <sup>B</sup> -71-80-90	71 <sup>C</sup> -80 <sup>C</sup> -90		35	
5.0	230	<b>278.62</b>	1.9	30/35/40			<b>603C</b>	<b>63A4</b>	63 <sup>B</sup> -71-80-90	71 <sup>C</sup> -80 <sup>C</sup> -90		37
5.8	199	<b>241.82</b>	1.8	28/30/35		<b>503A</b>	<b>63A4</b>	63 <sup>B</sup> -71-80-90	71 <sup>C</sup> -80 <sup>C</sup> -90	●	33	
5.8	199	<b>241.82</b>	2.2	30/35/40		<b>603A</b>	<b>63A4</b>	63 <sup>B</sup> -71-80-90	71 <sup>C</sup> -80 <sup>C</sup> -90	●	35	
6.2	185	<b>224.18</b>	2.7	30/35/40		<b>603A</b>	<b>63A4</b>	63 <sup>B</sup> -71-80-90	71 <sup>C</sup> -80 <sup>C</sup> -90		35	
6.2	185	<b>224.18</b>	2.7	30/35/40			<b>603C</b>	<b>63A4</b>	63 <sup>B</sup> -71-80-90	71 <sup>C</sup> -80 <sup>C</sup> -90		37
6.4	180	<b>218.26</b>	1.8	28/30/35		<b>503A</b>	<b>63A4</b>	63 <sup>B</sup> -71-80-90	71 <sup>C</sup> -80 <sup>C</sup> -90		33	
6.8	169	<b>205.43</b>	2.6	30/35/40		<b>603A</b>	<b>63A4</b>	63 <sup>B</sup> -71-80-90	71 <sup>C</sup> -80 <sup>C</sup> -90		35	
6.9	168	<b>204.16</b>	2.6	30/35/40			<b>603C</b>	<b>63A4</b>	63 <sup>B</sup> -71-80-90	71 <sup>C</sup> -80 <sup>C</sup> -90		37
7.6	153	<b>185.29</b>	2.9	30/35/40		<b>603A</b>	<b>63A4</b>	63 <sup>B</sup> -71-80-90	71 <sup>C</sup> -80 <sup>C</sup> -90		35	
7.6	153	<b>185.29</b>	2.9	30/35/40			<b>603C</b>	<b>63A4</b>	63 <sup>B</sup> -71-80-90	71 <sup>C</sup> -80 <sup>C</sup> -90		37
7.8	149	<b>180.40</b>	2.4	28/30/35		<b>503A</b>	<b>63A4</b>	63 <sup>B</sup> -71-80-90	71 <sup>C</sup> -80 <sup>C</sup> -90	●	33	
7.9	146	<b>177.09</b>	1.1	24/25		<b>403A</b>	<b>63A4</b>	63-71	56 <sup>B</sup> <sup>C</sup> -63 <sup>C</sup> -71	●	27	
8.4	137	<b>165.74</b>	1.3	24/25			<b>403C</b>	<b>63A4</b>	63 <sup>B</sup> -71-80-90	71 <sup>C</sup> -80 <sup>C</sup> -90		29
8.5	136	<b>165.20</b>	1.0	24/25		<b>403A</b>	<b>63A4</b>	63-71	56 <sup>B</sup> <sup>C</sup> -63 <sup>C</sup> -71		27	
10.3	112	<b>135.69</b>	1.4	24/25		<b>403A</b>	<b>63A4</b>	63-71	56 <sup>B</sup> <sup>C</sup> -63 <sup>C</sup> -71	●	27	
10.3	112	<b>135.69</b>	1.7	24/25			<b>403C</b>	<b>63A4</b>	63 <sup>B</sup> -71-80-90	71 <sup>C</sup> -80 <sup>C</sup> -90		29
11.1	104	<b>126.40</b>	1.5	24/25		<b>403A</b>	<b>63A4</b>	63-71	56 <sup>B</sup> <sup>C</sup> -63 <sup>C</sup> -71	●	27	
11.8	98	<b>118.29</b>	1.8	24/25			<b>403C</b>	<b>63A4</b>	63 <sup>B</sup> -71-80-90	71 <sup>C</sup> -80 <sup>C</sup> -90		29

B

Монтируются с проставкой  
Coupling by means of reduction bushing



C

Положение отверстий моторного  
фланца редуктора  
Motor flange/terminal box position





**ВЫБОР МОТОР-РЕДУКТОРОВ / GEARMOTORS SELECTION / WAHL DES GETRIEBEMOTORS  
SELECTION DES MOTO-REDUCTEURS / SELECCIYN MOTO.REDUCTORES**

**P<sub>1M</sub> = 0.13 kW**

**1400 min<sup>-1</sup> (63A4)**

n <sub>2</sub> [min <sup>-1</sup> ]	M <sub>2</sub> [Nm]	i	fs						IEC			
									B5	B14		
13.6	85	102.89	2.1	24/25								27
14.5	80	96.85	2.0	24/25							●	27
14.5	80	96.85	2.4	24/25			403C	63A4	63 <sup>B</sup> -71-80-90	71 <sup>C</sup> -80 <sup>C</sup> -90	●	29
16.2	72	86.66	1.9	24/25				63A4	63-71	56 <sup>B(C)</sup> -63 <sup>C</sup> -71		27
16.2	71	86.66	2.4	24/25			403C	63A4	63 <sup>B</sup> -71-80-90	71 <sup>C</sup> -80 <sup>C</sup> -90		29
18.7	62	74.77	2.8	24/25			403C	63A4	63 <sup>B</sup> -71-80-90	71 <sup>C</sup> -80 <sup>C</sup> -90		29
18.7	61	74.77	2.2	24/25			403A	63A4	63-71	56 <sup>B(C)</sup> -63 <sup>C</sup> -71		27
19.1	61	73.43	2.9	24/25			403A	63A4	63-71	56 <sup>B(C)</sup> -63 <sup>C</sup> -71		27
19.7	59	70.95	2.7	24/25			403A	63A4	63-71	56 <sup>B(C)</sup> -63 <sup>C</sup> -71	●	27
22.6	51	61.90	2.7	24/25			403A	63A4	63-71	56 <sup>B(C)</sup> -63 <sup>C</sup> -71		27
22.6	53	61.89	1.3	14/16			202A	63A4	63-71	56 <sup>B(C)</sup> -63 <sup>C</sup> -71		23
22.6	53	61.89	2.0	20			302A	63A4	63 <sup>B</sup> -71-80-90	71 <sup>C</sup> -80 <sup>C</sup> -90		25
22.6	53	61.88	2.6	24/25			402A	63A4	63 <sup>B</sup> -71-80-90	71 <sup>C</sup> -80 <sup>C</sup> -90		27
28.1	42	49.76	1.7	14/16			202A	63A4	63-71	56 <sup>B(C)</sup> -63 <sup>C</sup> -71	●	23
28.1	42	49.76	2.4	20			302A	63A4	63 <sup>B</sup> -71-80-90	71 <sup>C</sup> -80 <sup>C</sup> -90	●	25
29.9	40	46.87	1.8	14/16			202A	63A4	63-71	56 <sup>B(C)</sup> -63 <sup>C</sup> -71		23
29.9	40	46.87	2.7	20			302A	63A4	63 <sup>B</sup> -71-80-90	71 <sup>C</sup> -80 <sup>C</sup> -90		25
37.1	32	37.69	2.2	14/16			202A	63A4	63-71	56 <sup>B(C)</sup> -63 <sup>C</sup> -71	●	23
39.0	31	35.91	2.3	14/16			202A	63A4	63-71	56 <sup>B(C)</sup> -63 <sup>C</sup> -71		23
48.5	25	28.88	2.8	14/16			202A	63A4	63-71	56 <sup>B(C)</sup> -63 <sup>C</sup> -71	●	23
53	22	26.31	2.7	14/16			202A	63A4	63-71	56 <sup>B(C)</sup> -63 <sup>C</sup> -71		23
129	9	10.86	3.0	14		311		63A4	63-71	56 <sup>B(C)</sup> -63 <sup>C</sup> -71		19
129	9	10.86	3.0	19/24		411		63A4	63 <sup>B</sup> -71 <sup>B</sup> -80-90	71 <sup>B(C)</sup> -80 <sup>C</sup> -90		20
170	7	8.22	5.4	14		311		63A4	63-71	56 <sup>B(C)</sup> -63 <sup>C</sup> -71		19

**P<sub>1M</sub> = 0.18 kW**

**n<sub>1</sub> = 1400 min<sup>-1</sup> (63B4)- 900 min<sup>-1</sup> (71A6)**

3.9	415	363.63	1.0	30/35/40			603A	63B4	63 <sup>B</sup> -71-80-90	71 <sup>C</sup> -80 <sup>C</sup> -90		35	
4.4	365	319.32	1.0	28/30/35			503A	63B4	63 <sup>B</sup> -71-80-90	71 <sup>C</sup> -80 <sup>C</sup> -90	●	33	
4.8	334	292.57	1.0	28/30/35			503A	63B4	63 <sup>B</sup> -71-80-90	71 <sup>C</sup> -80 <sup>C</sup> -90		33	
4.8	334	292.57	1.5	30/35/40			603A	63B4	63 <sup>B</sup> -71-80-90	71 <sup>C</sup> -80 <sup>C</sup> -90	●	35	
5.0	318	278.62	1.4	30/35/40			603A	63B4	63 <sup>B</sup> -71-80-90	71 <sup>C</sup> -80 <sup>C</sup> -90		35	
5.0	318	278.62	1.4	30/35/40				603C	63B4	63 <sup>B</sup> -71-80-90	71 <sup>C</sup> -80 <sup>C</sup> -90		37
5.8	276	241.82	1.3	28/30/35			503A	63B4	63 <sup>B</sup> -71-80-90	71 <sup>C</sup> -80 <sup>C</sup> -90	●	33	
5.8	276	241.82	1.6	30/35/40			603A	63B4	63 <sup>B</sup> -71-80-90	71 <sup>C</sup> -80 <sup>C</sup> -90	●	35	
6.2	256	224.18	2.0	30/35/40			603A	63B4	63 <sup>B</sup> -71-80-90	71 <sup>C</sup> -80 <sup>C</sup> -90		35	
6.2	256	224.18	2.0	30/35/40				603C	63B4	63 <sup>B</sup> -71-80-90	71 <sup>C</sup> -80 <sup>C</sup> -90		37
6.4	249	218.26	1.3	28/30/35			503A	63B4	63 <sup>B</sup> -71-80-90	71 <sup>C</sup> -80 <sup>C</sup> -90		33	
6.8	235	205.43	1.9	30/35/40			603A	63B4	63 <sup>B</sup> -71-80-90	71 <sup>C</sup> -80 <sup>C</sup> -90		35	
6.9	233	204.16	1.9	30/35/40				603C	63B4	63 <sup>B</sup> -71-80-90	71 <sup>C</sup> -80 <sup>C</sup> -90		37
7.6	212	185.29	2.1	30/35/40			603A	63B4	63 <sup>B</sup> -71-80-90	71 <sup>C</sup> -80 <sup>C</sup> -90		35	
7.6	212	185.29	2.1	30/35/40				603C	63B4	63 <sup>B</sup> -71-80-90	71 <sup>C</sup> -80 <sup>C</sup> -90		37
7.8	206	180.40	1.7	28/30/35			503A	63B4	63 <sup>B</sup> -71-80-90	71 <sup>C</sup> -80 <sup>C</sup> -90	●	33	
8.4	189	165.74	0.9	24/25				403C	63B4	63 <sup>B</sup> -71-80-90	71 <sup>C</sup> -80 <sup>C</sup> -90		29
8.5	189	165.29	1.7	28/30/35			503A	63B4	63 <sup>B</sup> -71-80-90	71 <sup>C</sup> -80 <sup>C</sup> -90		33	
8.5	189	165.29	2.6	30/35/40			603A	63B4	63 <sup>B</sup> -71-80-90	71 <sup>C</sup> -80 <sup>C</sup> -90	●	35	
8.5	188	164.23	2.7	30/35/40				603C	63B4	63 <sup>B</sup> -71-80-90	71 <sup>C</sup> -80 <sup>C</sup> -90		37
8.9	180	157.40	2.4	30/35/40			603A	63B4	63 <sup>B</sup> -71-80-90	71 <sup>C</sup> -80 <sup>C</sup> -90		35	
8.9	180	157.40	2.4	30/35/40				603C	63B4	63 <sup>B</sup> -71-80-90	71 <sup>C</sup> -80 <sup>C</sup> -90		37
9.6	166	145.68	2.6	30/35/40			603A	63B4	63 <sup>B</sup> -71-80-90	71 <sup>C</sup> -80 <sup>C</sup> -90		35	
9.6	166	145.68	2.6	30/35/40				603C	63B4	63 <sup>B</sup> -71-80-90	71 <sup>C</sup> -80 <sup>C</sup> -90	●	37
10.2	156	136.62	2.3	28/30/35			503A	63B4	63 <sup>B</sup> -71-80-90	71 <sup>C</sup> -80 <sup>C</sup> -90	●	33	
10.3	155	135.74	2.8	30/35/40			603A	63B4	63 <sup>B</sup> -71-80-90	71 <sup>C</sup> -80 <sup>C</sup> -90		35	
10.3	155	135.74	2.8	30/35/40				603C	63B4	63 <sup>B</sup> -71-80-90	71 <sup>C</sup> -80 <sup>C</sup> -90		37

**B**

Монтируется с проставкой  
Coupling by means of reduction bushing



**C**

Положение отверстий моторного  
фланца редуктора  
Motor flange/terminal box position





**P<sub>1M</sub> = 0.18 kW**

n<sub>1</sub> = 1400 min<sup>-1</sup> (63B4)- 900 min<sup>-1</sup> (71A6)

n <sub>2</sub> [min <sup>-1</sup> ]	M <sub>2</sub> [Nm]	i	fs									
								B5	B14			
10.3	155	135.69	1.0	24/25		403A	63B4	63-71	56 <sup>B(C)</sup> -63 <sup>C</sup> -71	●	27	
10.3	155	135.69	1.3	24/25		403C	63B4	63 <sup>B</sup> -71-80-90	71 <sup>C</sup> -80 <sup>C</sup> -90		29	
11.1	145	126.65	2.3	28/30/35		503A	63B4	63 <sup>B</sup> -71-80-90	71 <sup>C</sup> -80 <sup>C</sup> -90		33	
11.1	144	126.40	1.1	24/25		403A	63B4	63-71	56 <sup>B(C)</sup> -63 <sup>C</sup> -71	●	27	
11.8	135	118.29	1.3	24/25			403C	63B4	63 <sup>B</sup> -71-80-90	71 <sup>C</sup> -80 <sup>C</sup> -90		29
11.9	134	117.22	2.4	28/30/35		503A	63B4	63 <sup>B</sup> -71-80-90	71 <sup>C</sup> -80 <sup>C</sup> -90		33	
13.4	120	104.67	3.0	28/30/35		503A	63B4	63 <sup>B</sup> -71-80-90	71 <sup>C</sup> -80 <sup>C</sup> -90	●	33	
13.6	117	102.89	1.5	24/25		403A	63B4	63-71	56 <sup>B(C)</sup> -63 <sup>C</sup> -71		27	
14.5	111	96.85	1.4	24/25		403A	63B4	63-71	56 <sup>B(C)</sup> -63 <sup>C</sup> -71	●	27	
14.5	111	96.85	1.8	24/25			403C	63B4	63 <sup>B</sup> -71-80-90	71 <sup>C</sup> -80 <sup>C</sup> -90	●	29
16.2	99	86.66	1.4	24/25		403A	63B4	63-71	56 <sup>B(C)</sup> -63 <sup>C</sup> -71		27	
16.2	99	86.66	1.8	24/25			403C	63B4	63 <sup>B</sup> -71-80-90	71 <sup>C</sup> -80 <sup>C</sup> -90		29
19.1	84	73.43	2.1	24/25		403A	63B4	63-71	56 <sup>B(C)</sup> -63 <sup>C</sup> -71		27	
19.7	81	70.95	2.0	24/25		403A	63B4	63-71	56 <sup>B(C)</sup> -63 <sup>C</sup> -71	●	27	
19.7	81	70.95	2.4	24/25			403C	63B4	63 <sup>B</sup> -71-80-90	71 <sup>C</sup> -80 <sup>C</sup> -90	●	29
22.6	73	61.89	1.0	14/16		202A	63B4	63-71	56 <sup>B(C)</sup> -63 <sup>C</sup> -71		23	
22.6	73	61.89	1.5	20		302A	63B4	63 <sup>B</sup> -71-80-90	71 <sup>C</sup> -80 <sup>C</sup> -90		25	
22.6	73	61.89	2.3	24/25			402C	63B4	63 <sup>B</sup> -71-80-90	71 <sup>C</sup> -80 <sup>C</sup> -90		29
22.6	73	61.88	1.9	24/25		402A	63B4	63 <sup>B</sup> -71-80-90	71 <sup>C</sup> -80 <sup>C</sup> -90		27	
22.9	70	61.22	2.3	24/25		403A	63B4	63-71	56 <sup>B(C)</sup> -63 <sup>C</sup> -71		27	
26.2	61	53.36	2.3	24/25		403A	63B4	63-71	56 <sup>B(C)</sup> -63 <sup>C</sup> -71		27	
27.6	60	50.67	2.2	24/25		402A	63B4	63 <sup>B</sup> -71-80-90	71 <sup>C</sup> -80 <sup>C</sup> -90		27	
27.6	60	50.67	2.5	24/25			402C	63B4	63 <sup>B</sup> -71-80-90	71 <sup>C</sup> -80 <sup>C</sup> -90		29
27.6	58	50.64	2.8	24/25		403A	63B4	63-71	56 <sup>B(C)</sup> -63 <sup>C</sup> -71	●	27	
28.1	59	49.76	1.2	14/16		202A	63B4	63-71	56 <sup>B(C)</sup> -63 <sup>C</sup> -71	●	23	
28.1	59	49.76	1.7	20		302A	63B4	63 <sup>B</sup> -71-80-90	71 <sup>C</sup> -80 <sup>C</sup> -90	●	25	
29.9	55	46.87	1.3	14/16		202A	63B4	63-71	56 <sup>B(C)</sup> -63 <sup>C</sup> -71		23	
29.9	55	46.87	1.9	20		302A	63B4	63 <sup>B</sup> -71-80-90	71 <sup>C</sup> -80 <sup>C</sup> -90		25	
29.9	55	46.86	2.5	24/25		402A	63B4	63 <sup>B</sup> -71-80-90	71 <sup>C</sup> -80 <sup>C</sup> -90		27	
32.0	50	43.69	3.0	24/25		403A	63B4	63-71	56 <sup>B(C)</sup> -63 <sup>C</sup> -71		27	
37.1	44	37.69	1.6	14/16		202A	63B4	63-71	56 <sup>B(C)</sup> -63 <sup>C</sup> -71	●	23	
37.1	44	37.69	2.3	20		302A	63B4	63 <sup>B</sup> -71-80-90	71 <sup>C</sup> -80 <sup>C</sup> -90	●	25	
39.0	42	35.91	1.7	14/16		202A	63B4	63-71	56 <sup>C</sup> -63 <sup>C</sup> -71		23	
39.0	42	35.91	2.5	20		302A	63B4	63 <sup>B</sup> -71-80-90	71 <sup>C</sup> -80 <sup>C</sup> -90		25	
48.5	34	28.88	2.1	14/16		202A	63B4	63-71	56 <sup>B(C)</sup> -63 <sup>C</sup> -71	●	23	
53	31	26.31	1.9	14/16		202A	63B4	63-71	56 <sup>B(C)</sup> -63 <sup>C</sup> -71		23	
64	26	21.84	2.3	14/16		202A	63B4	63-71	56 <sup>B(C)</sup> -63 <sup>C</sup> -71		23	
66	25	21.15	2.4	14/16		202A	63B4	63-71	56 <sup>B(C)</sup> -63 <sup>C</sup> -71	●	23	
75	22	18.78	2.7	14/16		202A	63B4	63-71	56 <sup>B(C)</sup> -63 <sup>C</sup> -71		23	
83	20	10.86	1.4	14	311		71A6	63-71	56 <sup>B(C)</sup> -63 <sup>C</sup> -71		19	
86	19	16.20	3.1	14/16		202A	63B4	63-71	56 <sup>B(C)</sup> -63 <sup>C</sup> -71		23	
93	18	15.10	3.4	14/16		202A	63B4	63-71	56 <sup>B(C)</sup> -63 <sup>C</sup> -71	●	23	
123	13	11.42	4.5	14/16		202A	63B4	63-71	56 <sup>B(C)</sup> -63 <sup>C</sup> -71		23	
129	13	10.86	2.2	14	311		63B4	63-71	56 <sup>B(C)</sup> -63 <sup>C</sup> -71		19	

**P<sub>1M</sub> = 0.25 kW**

1400 min<sup>-1</sup> (71A4) - 900 min<sup>-1</sup> (71B6)

4.8	464	292.57	1.1	30/35/40		603A	71A4	63 <sup>B</sup> -71-80-90	71 <sup>C</sup> -80 <sup>C</sup> -90	●	35	
5.0	442	278.62	1.0	30/35/40		603A	71A4	63 <sup>B</sup> -71-80-90	71 <sup>C</sup> -80 <sup>C</sup> -90		35	
5.0	442	278.62	1.0	30/35/40			603C	71A4	63 <sup>B</sup> -71-80-90	71 <sup>C</sup> -80 <sup>C</sup> -90		37
5.8	384	241.82	0.9	28/30/35		503A	71A4	63 <sup>B</sup> -71-80-90	71 <sup>C</sup> -80 <sup>C</sup> -90	●	33	
5.8	384	241.82	1.1	30/35/40		603A	71A4	63 <sup>B</sup> -71-80-90	71 <sup>C</sup> -80 <sup>C</sup> -90	●	35	
6.2	356	224.18	1.4	30/35/40		603A	71A4	63 <sup>B</sup> -71-80-90	71 <sup>C</sup> -80 <sup>C</sup> -90		35	
6.2	356	224.18	1.4	30/35/40			603C	71A4	63 <sup>B</sup> -71-80-90	71 <sup>C</sup> -80 <sup>C</sup> -90		37
6.4	346	218.26	0.9	28/30/35		503A	71A4	63 <sup>B</sup> -71-80-90	71 <sup>C</sup> -80 <sup>C</sup> -90		33	

B

Монтируется с проставкой  
Coupling by means of reduction bushing



C

Положение отверстий моторного  
фланца редуктора  
Motor flange/terminal box position





**ВЫБОР МОТОР-РЕДУКТОРОВ / GEARMOTORS SELECTION / WAHL DES GETRIEBEMOTORS  
SELECTION DES MOTO-REDUCTEURS / SELECCIYN MOTO-REDUCTORES**

**P<sub>1M</sub> = 0.25 kW**

**1400 min<sup>-1</sup> (71A4) - 900 min<sup>-1</sup> (71B6)**

n <sub>2</sub> [min <sup>-1</sup> ]	M <sub>2</sub> [Nm]	i	fs										Размеры на странице
									B5	B14			
6.8	326	205.43	1.3	30/35/40									35
6.9	324	204.16	1.3	30/35/40									37
7.6	294	185.29	1.5	30/35/40									35
7.6	294	185.29	1.5	30/35/40									37
7.8	286	180.40	1.2	28/30/35								●	33
8.5	262	165.29	1.2	28/30/35									33
8.5	262	165.29	1.9	30/35/40								●	35
8.5	260	164.23	1.9	30/35/40									37
8.9	250	157.40	1.7	30/35/40									35
8.9	250	157.40	1.7	30/35/40									37
9.6	231	145.68	1.9	30/35/40									35
9.6	231	145.68	1.9	30/35/40								●	37
10.2	217	136.62	1.6	28/30/35								●	33
10.3	215	135.74	2.0	30/35/40									35
10.3	215	135.74	2.0	30/35/40									37
10.3	215	135.69	0.9	24/25									29
11.1	201	126.65	1.6	28/30/35									33
11.1	201	126.65	2.5	30/35/40								●	35
11.1	201	126.65	2.5	30/35/40									37
11.8	188	118.29	0.9	24/25									29
11.9	186	117.22	1.8	28/30/35									33
11.9	186	117.22	2.7	30/35/40									35
11.9	186	117.22	2.7	30/35/40								●	37
13.4	166	104.68	3.0	30/35/40								●	35
13.4	166	104.68	3.0	30/35/40									37
13.4	166	104.67	2.1	28/30/35								●	33
13.6	163	102.89	1.1	24/25									27
14.5	154	96.85	1.0	24/25								●	27
14.5	154	96.85	1.3	24/25								●	29
15.1	147	92.78	2.2	28/30/35									33
16.2	138	86.66	1.0	24/25									27
16.2	137	86.66	1.3	24/25									29
16.7	133	83.59	2.7	28/30/35									33
18.7	119	74.77	1.5	24/25									29
18.7	118	74.77	1.2	24/25									27
19.1	116	73.43	1.5	24/25									27
19.7	113	70.95	1.4	24/25								●	27
19.7	113	70.95	1.7	24/25								●	29
22.5	99	62.22	2.0	24/25									29
22.6	98	61.90	1.4	24/25									27
22.6	101	61.89	1.1	20									25
22.6	101	61.89	1.7	24/25									29
22.6	101	61.88	1.4	24/25									27
22.9	97	61.22	1.6	24/25									27
23.0	100	60.90	2.5	28/30/35									33
23.0	100	60.90	2.7	28/30/35									31
26.2	85	53.36	1.6	24/25									27
27.6	83	50.67	1.6	24/25									27
27.6	83	50.67	1.8	24/25									29
27.6	80	50.64	2.0	24/25								●	27
27.6	80	50.64	2.4	24/25								●	29
28.1	81	49.76	0.9	14/16								●	23
28.1	81	49.76	1.2	20								●	25
29.9	77	46.87	0.9	14/16									23
29.9	77	46.87	1.4	20									25
29.9	77	46.87	2.2	24/25									29
29.9	77	46.86	1.8	24/25									27
32.0	69	43.69	2.2	24/25									27
32.0	69	43.69	2.8	24/25									29
36.5	61	38.40	2.9	24/25								●	27





**P<sub>1M</sub> = 0.25 kW**

1400 min<sup>-1</sup> (71A4) - 900 min<sup>-1</sup> (71B6)

n <sub>2</sub> [min <sup>-1</sup> ]	M <sub>2</sub> [Nm]	i	fs									
									B5	B14		
36.5	63	38.37	2.5	24/25			402A	71A4	63 <sup>B</sup> -71-80-90	71 <sup>C</sup> -80 <sup>C</sup> -90		27
36.5	63	38.37	2.9	24/25			402C	71A4	63 <sup>B</sup> -71-80-90	71 <sup>C</sup> -80 <sup>C</sup> -90		29
36.5	61	38.34	2.9	24/25			403C	71A4	63 <sup>B</sup> -71-80-90	71 <sup>C</sup> -80 <sup>C</sup> -90	●	29
37.1	62	37.69	1.1	14/16			202A	71A4	63-71	56 <sup>B</sup> <sup>C</sup> -63 <sup>C</sup> -71	●	23
37.1	62	37.69	1.7	20			302A	71A4	63 <sup>B</sup> -71-80-90	71 <sup>C</sup> -80 <sup>C</sup> -90	●	25
39.0	59	35.91	1.2	14/16			202A	71A4	63-71	56 <sup>B</sup> <sup>C</sup> -63 <sup>C</sup> -71		23
39.0	59	35.91	1.8	20			302A	71A4	63 <sup>B</sup> -71-80-90	71 <sup>C</sup> -80 <sup>C</sup> -90		25
39.0	59	35.91	2.3	24/25			402A	71A4	63 <sup>B</sup> -71-80-90	71 <sup>C</sup> -80 <sup>C</sup> -90	●	27
39.0	59	35.91	2.9	24/25			402C	71A4	63 <sup>B</sup> -71-80-90	71 <sup>C</sup> -80 <sup>C</sup> -90	●	29
42.6	54	21.15	1.1	14/16			202A	71B6	63-71	56 <sup>B</sup> <sup>C</sup> -63 <sup>C</sup> -71	●	23
48.5	47	28.88	1.5	14/16			202A	71A4	63-71	56 <sup>B</sup> <sup>C</sup> -63 <sup>C</sup> -71	●	23
48.5	47	28.88	2.4	20			302A	71A4	63 <sup>B</sup> -71-80-90	71 <sup>C</sup> -80 <sup>C</sup> -90	●	25
53	43	26.31	1.4	14/16			202A	71A4	63-71	56 <sup>B</sup> <sup>C</sup> -63 <sup>C</sup> -71		23
53	43	26.31	2.5	20			302A	71A4	63 <sup>B</sup> -71-80-90	71 <sup>C</sup> -80 <sup>C</sup> -90		25
64	36	21.84	1.7	14/16			202A	71A4	63-71	56 <sup>B</sup> <sup>C</sup> -63 <sup>C</sup> -71		23
66	35	21.15	1.7	14/16			202A	71A4	63-71	56 <sup>B</sup> <sup>C</sup> -63 <sup>C</sup> -71	●	23
75	31	18.78	2.0	14/16			202A	71A4	63-71	56 <sup>B</sup> <sup>C</sup> -63 <sup>C</sup> -71		23
86	27	16.20	2.3	14/16			202A	71A4	63-71	56 <sup>B</sup> <sup>C</sup> -63 <sup>C</sup> -71		23
93	25	15.10	2.4	14/16			202A	71A4	63-71	56 <sup>B</sup> <sup>C</sup> -63 <sup>C</sup> -71	●	23
107	21	13.03	2.8	14/16			202A	71A4	63-71	56 <sup>B</sup> <sup>C</sup> -63 <sup>C</sup> -71		23
123	19	11.42	3.2	14/16			202A	71A4	63-71	56 <sup>B</sup> <sup>C</sup> -63 <sup>C</sup> -71		23
129	18	10.86	1.6	14	311			71A4	63-71	56 <sup>B</sup> <sup>C</sup> -63 <sup>C</sup> -71		19
142	16	9.85	3.7	14/16			202A	71A4	63-71	56 <sup>B</sup> <sup>C</sup> -63 <sup>C</sup> -71	●	23
170	14	8.22	2.8	14	311			71A4	63-71	56 <sup>B</sup> <sup>C</sup> -63 <sup>C</sup> -71		19
170	14	8.22	2.8	19/24	411			71A4	63 <sup>B</sup> -71 <sup>B</sup> -80-90	71 <sup>B</sup> <sup>C</sup> -80 <sup>C</sup> -90		20
181	13	7.74	3.9	14/16			202A	71A4	63-71	56 <sup>B</sup> <sup>C</sup> -63 <sup>C</sup> -71		23
194	12	7.20	4.2	14/16			202A	71A4	63-71	56 <sup>B</sup> <sup>C</sup> -63 <sup>C</sup> -71		23
222	11	6.30	4.5	14	311			71A4	63-71	56 <sup>B</sup> <sup>C</sup> -63 <sup>C</sup> -71		19
257	9	5.45	5.6	14/16			202A	71A4	63-71	56 <sup>B</sup> <sup>C</sup> -63 <sup>C</sup> -71	●	23
303	8	4.62	6.3	14	311			71A4	63-71	56 <sup>B</sup> <sup>C</sup> -63 <sup>C</sup> -71		19

**P<sub>1M</sub> = 0.37 kW**

1400 min<sup>-1</sup> (71B4)

6.2	526	224.18	1.0	30/35/40			603A	71B4	63 <sup>B</sup> -71-80-90	71 <sup>C</sup> -80 <sup>C</sup> -90		35
6.2	526	224.18	1.0	30/35/40			603C	71B4	63 <sup>B</sup> -71-80-90	71 <sup>C</sup> -80 <sup>C</sup> -90		37
6.8	482	205.43	0.9	30/35/40			603A	71B4	63 <sup>B</sup> -71-80-90	71 <sup>C</sup> -80 <sup>C</sup> -90		35
6.9	479	204.16	0.9	30/35/40			603C	71B4	63 <sup>B</sup> -71-80-90	71 <sup>C</sup> -80 <sup>C</sup> -90		37
7.6	435	185.29	1.0	30/35/40			603A	71B4	63 <sup>B</sup> -71-80-90	71 <sup>C</sup> -80 <sup>C</sup> -90		35
7.6	435	185.29	1.0	30/35/40			603C	71B4	63 <sup>B</sup> -71-80-90	71 <sup>C</sup> -80 <sup>C</sup> -90		37
7.8	423	180.40	0.8	28/30/35			503A	71B4	63 <sup>B</sup> -71-80-90	71 <sup>C</sup> -80 <sup>C</sup> -90	●	33
8.5	388	165.29	0.8	28/30/35			503A	71B4	63 <sup>B</sup> -71-80-90	71 <sup>C</sup> -80 <sup>C</sup> -90		33
8.5	388	165.29	1.3	30/35/40			603A	71B4	63 <sup>B</sup> -71-80-90	71 <sup>C</sup> -80 <sup>C</sup> -90	●	35
8.5	385	164.23	1.3	30/35/40			603C	71B4	63 <sup>B</sup> -71-80-90	71 <sup>C</sup> -80 <sup>C</sup> -90		37
8.9	369	157.40	1.2	30/35/40			603A	71B4	63 <sup>B</sup> -71-80-90	71 <sup>C</sup> -80 <sup>C</sup> -90		35
8.9	369	157.40	1.2	30/35/40			603C	71B4	63 <sup>B</sup> -71-80-90	71 <sup>C</sup> -80 <sup>C</sup> -90		37
9.6	342	145.68	1.3	30/35/40			603A	71B4	63 <sup>B</sup> -71-80-90	71 <sup>C</sup> -80 <sup>C</sup> -90		35
9.6	342	145.68	1.3	30/35/40			603C	71B4	63 <sup>B</sup> -71-80-90	71 <sup>C</sup> -80 <sup>C</sup> -90	●	37
10.2	321	136.62	1.1	28/30/35			503A	71B4	63 <sup>B</sup> -71-80-90	71 <sup>C</sup> -80 <sup>C</sup> -90	●	33
10.3	319	135.74	1.4	30/35/40			603A	71B4	63 <sup>B</sup> -71-80-90	71 <sup>C</sup> -80 <sup>C</sup> -90		35
10.3	319	135.74	1.4	30/35/40			603C	71B4	63 <sup>B</sup> -71-80-90	71 <sup>C</sup> -80 <sup>C</sup> -90		37
11.1	297	126.65	1.1	28/30/35			503A	71B4	63 <sup>B</sup> -71-80-90	71 <sup>C</sup> -80 <sup>C</sup> -90		33
11.1	297	126.65	1.7	30/35/40			603A	71B4	63 <sup>B</sup> -71-80-90	71 <sup>C</sup> -80 <sup>C</sup> -90	●	35
11.1	297	126.65	1.7	30/35/40			603C	71B4	63 <sup>B</sup> -71-80-90	71 <sup>C</sup> -80 <sup>C</sup> -90		37
11.9	275	117.22	1.2	28/30/35			503A	71B4	63 <sup>B</sup> -71-80-90	71 <sup>C</sup> -80 <sup>C</sup> -90		33
11.9	275	117.22	1.8	30/35/40			603A	71B4	63 <sup>B</sup> -71-80-90	71 <sup>C</sup> -80 <sup>C</sup> -90		35

B

Монтируется с проставкой  
Coupling by means of reduction bushing



C

Положение отверстий моторного  
фланца редуктора  
Motor flange/terminal box position





ВЫБОР МОТОР-РЕДУКТОРОВ / GEARMOTORS SELECTION / WAHL DES GETRIEBEMOTORS  
SELECTION DES MOTO-REDUCTEURS / SELECCIYN MOTO-REDUCTORES

$P_{1M} = 0.37 \text{ kW}$

1400 min<sup>-1</sup> (71B4)

n <sub>2</sub> [min <sup>-1</sup> ]	M <sub>2</sub> [Nm]	i	fs										
									B5	B14			
11.9	275	117.22	1.8	30/35/40				603C	71B4	63 <sup>B</sup> -71-80-90	71 <sup>C</sup> -80 <sup>C</sup> -90	●	37
13.4	246	104.68	2.0	30/35/40			603A		71B4	63 <sup>B</sup> -71-80-90	71 <sup>C</sup> -80 <sup>C</sup> -90	●	35
13.4	246	104.68	2.0	30/35/40				603C	71B4	63 <sup>B</sup> -71-80-90	71 <sup>C</sup> -80 <sup>C</sup> -90		37
13.4	246	104.67	1.4	28/30/35			503A		71B4	63 <sup>B</sup> -71-80-90	71 <sup>C</sup> -80 <sup>C</sup> -90	●	33
14.5	227	96.85	0.9	24/25				403C	71B4	63 <sup>B</sup> -71-80-90	71 <sup>C</sup> -80 <sup>C</sup> -90	●	29
15.1	218	92.78	1.5	28/30/35			503A		71B4	63 <sup>B</sup> -71-80-90	71 <sup>C</sup> -80 <sup>C</sup> -90		33
15.1	218	92.78	2.3	30/35/40			603A		71B4	63 <sup>B</sup> -71-80-90	71 <sup>C</sup> -80 <sup>C</sup> -90		35
15.1	218	92.78	2.3	30/35/40				603C	71B4	63 <sup>B</sup> -71-80-90	71 <sup>C</sup> -80 <sup>C</sup> -90		37
16.2	203	86.66	0.9	24/25				403C	71B4	63 <sup>B</sup> -71-80-90	71 <sup>C</sup> -80 <sup>C</sup> -90		29
16.7	196	83.59	1.8	28/30/35			503A		71B4	63 <sup>B</sup> -71-80-90	71 <sup>C</sup> -80 <sup>C</sup> -90		33
16.7	196	83.59	2.2	30/35/40			603A		71B4	63 <sup>B</sup> -71-80-90	71 <sup>C</sup> -80 <sup>C</sup> -90		35
16.7	196	83.59	2.2	30/35/40				603C	71B4	63 <sup>B</sup> -71-80-90	71 <sup>C</sup> -80 <sup>C</sup> -90	●	37
17.0	193	82.30	2.3	30/35/40			603A		71B4	63 <sup>B</sup> -71-80-90	71 <sup>C</sup> -80 <sup>C</sup> -90		35
17.0	193	82.30	2.3	30/35/40				603C	71B4	63 <sup>B</sup> -71-80-90	71 <sup>C</sup> -80 <sup>C</sup> -90		37
18.3	180	76.69	2.0	28/30/35			503A		71B4	63 <sup>B</sup> -71-80-90	71 <sup>C</sup> -80 <sup>C</sup> -90	●	33
18.3	180	76.69	2.8	30/35/40			603A		71B4	63 <sup>B</sup> -71-80-90	71 <sup>C</sup> -80 <sup>C</sup> -90	●	35
18.3	180	76.69	2.8	30/35/40				603C	71B4	63 <sup>B</sup> -71-80-90	71 <sup>C</sup> -80 <sup>C</sup> -90		37
18.7	176	74.77	1.0	24/25				403C	71B4	63 <sup>B</sup> -71-80-90	71 <sup>C</sup> -80 <sup>C</sup> -90		29
19.1	172	73.43	1.0	24/25			403A		71B4	63-71	56 <sup>B</sup> -63 <sup>C</sup> -71		27
19.7	167	71.01	2.6	30/35/40			603A		71B4	63 <sup>B</sup> -71-80-90	71 <sup>C</sup> -80 <sup>C</sup> -90		35
19.7	167	71.01	2.6	30/35/40				603C	71B4	63 <sup>B</sup> -71-80-90	71 <sup>C</sup> -80 <sup>C</sup> -90	●	37
19.7	167	70.95	1.0	24/25			403A		71B4	63-71	56 <sup>B</sup> -63 <sup>C</sup> -71	●	27
19.7	167	70.95	1.2	24/25				403C	71B4	63 <sup>B</sup> -71-80-90	71 <sup>C</sup> -80 <sup>C</sup> -90	●	29
21.1	155	66.22	2.1	28/30/35			503A		71B4	63 <sup>B</sup> -71-80-90	71 <sup>C</sup> -80 <sup>C</sup> -90		33
22.5	146	62.22	1.3	24/25				403C	71B4	63 <sup>B</sup> -71-80-90	71 <sup>C</sup> -80 <sup>C</sup> -90		29
22.6	146	61.90	0.9	24/25			403A		71B4	63-71	56 <sup>B</sup> -63 <sup>C</sup> -71		27
22.6	150	61.89	1.1	24/25				402C	71B4	63 <sup>B</sup> -71-80-90	71 <sup>C</sup> -80 <sup>C</sup> -90		29
22.6	150	61.88	0.9	24/25			402A		71B4	63 <sup>B</sup> -71-80-90	71 <sup>C</sup> -80 <sup>C</sup> -90		27
22.9	144	61.22	1.1	24/25			403A		71B4	63-71	56 <sup>B</sup> -63 <sup>C</sup> -71		27
23.0	148	60.90	1.7	28/30/35			502A		71B4	71 <sup>B</sup> -80-90-100/112	80-90-100/112		33
23.0	148	60.90	1.8	28/30/35			452A		71B4	71 <sup>B</sup> -80-90-100/112	80-90-100/112		31
23.0	148	60.90	2.7	30/35/40			602A		71B4	71 <sup>B</sup> -80-90-100/112	80-90-100/112		35
23.0	148	60.90	2.9	30/35/40				602C	71B4	71 <sup>B</sup> -80-90-100/112	80-90-100/112		37
25.6	128	54.73	2.8	28/30/35			503A		71B4	63 <sup>B</sup> -71-80-90	71 <sup>C</sup> -80 <sup>C</sup> -90	●	33
26.2	125	53.36	1.1	24/25			403A		71B4	63-71	56 <sup>B</sup> -63 <sup>C</sup> -71		27
27.6	123	50.67	1.1	24/25			402A		71B4	63 <sup>B</sup> -71-80-90	71 <sup>C</sup> -80 <sup>C</sup> -90		27
27.6	123	50.67	1.2	24/25				402C	71B4	63 <sup>B</sup> -71-80-90	71 <sup>C</sup> -80 <sup>C</sup> -90		29
27.6	119	50.64	1.3	24/25			403A		71B4	63-71	56 <sup>B</sup> -63 <sup>C</sup> -71	●	27
27.6	119	50.64	1.6	24/25				403C	71B4	63 <sup>B</sup> -71-80-90	71 <sup>C</sup> -80 <sup>C</sup> -90	●	29
28.1	121	49.76	0.8	20			302A		71B4	63 <sup>B</sup> -71-80-90	71 <sup>C</sup> -80 <sup>C</sup> -90	●	25
28.6	119	49.00	2.5	28/30/35			452A		71B4	71 <sup>B</sup> -80-90-100/112	80-90-100/112		31
28.6	119	49.00	2.7	28/30/35			502A		71B4	71 <sup>B</sup> -80-90-100/112	80-90-100/112		33
29.9	114	46.87	0.9	20			302A		71B4	63 <sup>B</sup> -71-80-90	71 <sup>C</sup> -80 <sup>C</sup> -90		25
29.9	114	46.87	1.5	24/25				402C	71B4	63 <sup>B</sup> -71-80-90	71 <sup>C</sup> -80 <sup>C</sup> -90		29
29.9	114	46.86	1.2	24/25			402A		71B4	63 <sup>B</sup> -71-80-90	71 <sup>C</sup> -80 <sup>C</sup> -90		27
31.7	107	44.23	2.3	28/30/35			502A		71B4	71 <sup>B</sup> -80-90-100/112	80-90-100/112		33
31.7	107	44.22	2.5	28/30/35			452A		71B4	71 <sup>B</sup> -80-90-100/112	80-90-100/112		31
32.0	103	43.69	1.5	24/25			403A		71B4	63-71	56 <sup>B</sup> -63 <sup>C</sup> -71		27
32.0	103	43.69	1.9	24/25				403C	71B4	63 <sup>B</sup> -71-80-90	71 <sup>C</sup> -80 <sup>C</sup> -90		29
34.6	98	40.50	3.0	28/30/35			452A		71B4	71 <sup>B</sup> -80-90-100/112	80-90-100/112		31
34.6	98	40.50	3.0	28/30/35			502A		71B4	71 <sup>B</sup> -80-90-100/112	80-90-100/112		33
36.5	90	38.40	1.9	24/25			403A		71B4	63-71	56 <sup>B</sup> -63 <sup>C</sup> -71	●	27
36.5	93	38.37	1.7	24/25			402A		71B4	63 <sup>B</sup> -71-80-90	71 <sup>C</sup> -80 <sup>C</sup> -90		27
36.5	93	38.37	1.9	24/25				402C	71B4	63 <sup>B</sup> -71-80-90	71 <sup>C</sup> -80 <sup>C</sup> -90		29
36.5	90	38.34	1.9	24/25				403C	71B4	63 <sup>B</sup> -71-80-90	71 <sup>C</sup> -80 <sup>C</sup> -90	●	29
37.1	91	37.69	1.1	20			302A		71B4	63 <sup>B</sup> -71-80-90	71 <sup>C</sup> -80 <sup>C</sup> -90	●	25

B

Монтируется с проставкой  
Coupling by means of reduction bushing



C

Положение отверстий моторного  
фланца редуктора  
Motor flange/terminal box position







**P<sub>1M</sub> = 0.37 kW**

**1400 min<sup>-1</sup> (71B4)**

n <sub>2</sub> [min <sup>-1</sup> ]	M <sub>2</sub> [Nm]	i	fs						1400 min <sup>-1</sup> (71B4)			
									B5	B14		
39.0	87	35.91	0.8	14/16								23
39.0	87	35.91	1.2	20								25
39.0	87	35.91	1.6	24/25							●	27
39.0	87	35.91	2.0	24/25			402C	71B4	63 <sup>B)</sup> -71-80-90	71 <sup>C)</sup> -80 <sup>C)</sup> -90	●	29
47.6	71	29.40	2.2	24/25			402A	71B4	63 <sup>B)</sup> -71-80-90	71 <sup>C)</sup> -80 <sup>C)</sup> -90		27
47.6	71	29.40	2.8	24/25				402C	71B4	63 <sup>B)</sup> -71-80-90		29
48.5	70	28.88	1.0	14/16			202A	71B4	63-71	56 <sup>B)</sup> -63 <sup>C)</sup> -71	●	23
48.5	70	28.88	1.6	20			302A	71B4	63 <sup>B)</sup> -71-80-90	71 <sup>C)</sup> -80 <sup>C)</sup> -90	●	25
53	64	26.31	0.9	14/16			202A	71B4	63-71	56 <sup>B)</sup> -63 <sup>C)</sup> -71		23
53	64	26.31	1.7	20			302A	71B4	63 <sup>B)</sup> -71-80-90	71 <sup>C)</sup> -80 <sup>C)</sup> -90		25
53	64	26.31	2.7	24/25				402C	71B4	63 <sup>B)</sup> -71-80-90	●	29
53	64	26.30	2.2	24/25			402A	71B4	63 <sup>B)</sup> -71-80-90	71 <sup>C)</sup> -80 <sup>C)</sup> -90	●	27
63	54	22.26	2.9	24/25				402C	71B4	63 <sup>B)</sup> -71-80-90		29
64	53	21.84	1.1	14/16			202A	71B4	63-71	56 <sup>B)</sup> -63 <sup>C)</sup> -71		23
64	53	21.84	2.2	20			302A	71B4	63 <sup>B)</sup> -71-80-90	71 <sup>C)</sup> -80 <sup>C)</sup> -90		25
66	51	21.15	1.2	14/16			202A	71B4	63-71	56 <sup>B)</sup> -63 <sup>C)</sup> -71	●	23
66	51	21.15	2.2	20			302A	71B4	63 <sup>B)</sup> -71-80-90	71 <sup>C)</sup> -80 <sup>C)</sup> -90	●	25
74	46	18.80	3.0	24/25			402A	71B4	63 <sup>B)</sup> -71-80-90	71 <sup>C)</sup> -80 <sup>C)</sup> -90		27
75	46	18.78	1.3	14/16			202A	71B4	63-71	56 <sup>B)</sup> -63 <sup>C)</sup> -71		23
75	46	18.78	2.4	20			302A	71B4	63 <sup>B)</sup> -71-80-90	71 <sup>C)</sup> -80 <sup>C)</sup> -90		25
86	39	16.20	1.5	14/16			202A	71B4	63-71	56 <sup>B)</sup> -63 <sup>C)</sup> -71		23
86	39	16.20	2.7	20			302A	71B4	63 <sup>B)</sup> -71-80-90	71 <sup>C)</sup> -80 <sup>C)</sup> -90		25
93	37	15.10	1.6	14/16			202A	71B4	63-71	56 <sup>B)</sup> -63 <sup>C)</sup> -71	●	23
107	32	13.03	1.9	14/16			202A	71B4	63-71	56 <sup>B)</sup> -63 <sup>C)</sup> -71		23
123	28	11.42	2.2	14/16			202A	71B4	63-71	56 <sup>B)</sup> -63 <sup>C)</sup> -71		23
129	27	10.86	1.0	14	311			71B4	63-71	56 <sup>B)</sup> -63 <sup>C)</sup> -71		19
129	27	10.86	1.1	19/24	411			71B4	63 <sup>B)</sup> -71-80-90	71 <sup>C)</sup> -80 <sup>C)</sup> -90		20
133	26	10.50	3.0	24/28	511			71B4	71 <sup>B)</sup> -80-90-100/112	80-90-100/112		21
142	24	9.85	2.5	14/16			202A	71B4	63-71	56 <sup>B)</sup> -63 <sup>C)</sup> -71	●	23
170	20	8.22	1.9	14	311			71B4	63-71	56 <sup>B)</sup> -63 <sup>C)</sup> -71		19
170	20	8.22	1.9	19/24	411			71B4	63 <sup>B)</sup> -71 <sup>B)</sup> -80-90	71 <sup>C)</sup> -80 <sup>C)</sup> -90		20
181	19	7.74	2.7	14/16			202A	71B4	63-71	56 <sup>B)</sup> -63 <sup>C)</sup> -71		23
194	17	7.20	2.9	14/16			202A	71B4	63-71	56 <sup>B)</sup> -63 <sup>C)</sup> -71		23
222	16	6.30	3.0	14	311			71B4	63-71	56 <sup>B)</sup> -63 <sup>C)</sup> -71		19
222	16	6.30	3.0	19/24	411			71B4	63 <sup>B)</sup> -71 <sup>B)</sup> -80-90	71 <sup>C)</sup> -80 <sup>C)</sup> -90		20
303	11	4.62	4.2	14	311			71B4	63-71	56 <sup>B)</sup> -63 <sup>C)</sup> -71		19
362	10	3.87	4.2	14	311			71B4	63-71	56 <sup>B)</sup> -63 <sup>C)</sup> -71		19
426	8	3.29	6.1	14	311			71B4	63-71	56 <sup>B)</sup> -63 <sup>C)</sup> -71		19
493	7	2.84	6.1	14	311			71B4	63-71	56 <sup>B)</sup> -63 <sup>C)</sup> -71		19

**P<sub>1M</sub> = 0.55 kW**

**1400 min<sup>-1</sup> (80A4)**

8.5	577	165.29	0.9	30/35/40			603A	80A4	63 <sup>B)</sup> -71-80-90	71 <sup>C)</sup> -80 <sup>C)</sup> -90	●	35
8.5	573	164.23	0.9	30/35/40				603C	80A4	63 <sup>B)</sup> -71-80-90		37
9.6	508	145.68	0.9	30/35/40			603A	80A4	63 <sup>B)</sup> -71-80-90	71 <sup>C)</sup> -80 <sup>C)</sup> -90		35
9.6	508	145.68	0.9	30/35/40				603C	80A4	63 <sup>B)</sup> -71-80-90	●	37
10.3	474	135.74	0.9	30/35/40			603A	80A4	63 <sup>B)</sup> -71-80-90	71 <sup>C)</sup> -80 <sup>C)</sup> -90		35
10.3	474	135.74	0.9	30/35/40				603C	80A4	63 <sup>B)</sup> -71-80-90		37
11.1	442	126.65	1.1	30/35/40			603A	80A4	63 <sup>B)</sup> -71-80-90	71 <sup>C)</sup> -80 <sup>C)</sup> -90	●	35
11.1	442	126.65	1.1	30/35/40				603C	80A4	63 <sup>B)</sup> -71-80-90		37
11.9	409	117.22	1.2	30/35/40			603A	80A4	63 <sup>B)</sup> -71-80-90	71 <sup>C)</sup> -80 <sup>C)</sup> -90		35
11.9	409	117.22	1.2	30/35/40				603C	80A4	63 <sup>B)</sup> -71-80-90	●	37
13.4	365	104.68	1.4	30/35/40			603A	80A4	63 <sup>B)</sup> -71-80-90	71 <sup>C)</sup> -80 <sup>C)</sup> -90	●	35
13.4	365	104.68	1.4	30/35/40				603C	80A4	63 <sup>B)</sup> -71-80-90		37

B

Монтируется с проставкой  
Coupling by means of reduction bushing



C

Положение отверстий моторного  
фланца редуктора  
Motor flange/terminal box position





ВЫБОР МОТОР-РЕДУКТОРОВ / GEARMOTORS SELECTION / WAHL DES GETRIEBEMOTORS  
SELECTION DES MOTO-REDUCTEURS / SELECCIYN MOTO-REDUCTORES

**P<sub>1M</sub> = 0.55 kW**

**1400 min<sup>-1</sup> (80A4)**

n <sub>2</sub> [min <sup>-1</sup> ]	M <sub>2</sub> [Nm]	i	fs											
									B5	B14				
13.4	365	104.67	1.0	28/30/35				503A	80A4	63 <sup>B)</sup> -71-80-90	71 <sup>C)</sup> -80 <sup>C)</sup> -90	●	33	
15.1	324	92.78	1.0	28/30/35				503A	80A4	63 <sup>B)</sup> -71-80-90	71 <sup>C)</sup> -80 <sup>C)</sup> -90		33	
15.1	324	92.78	1.5	30/35/40				603A	80A4	63 <sup>B)</sup> -71-80-90	71 <sup>C)</sup> -80 <sup>C)</sup> -90		35	
15.1	324	92.78	1.5	30/35/40					603C	80A4	63 <sup>B)</sup> -71-80-90	71 <sup>C)</sup> -80 <sup>C)</sup> -90		37
16.7	292	83.59	1.2	28/30/35				503A	80A4	63 <sup>B)</sup> -71-80-90	71 <sup>C)</sup> -80 <sup>C)</sup> -90		33	
16.7	292	83.59	1.5	30/35/40				603A	80A4	63 <sup>B)</sup> -71-80-90	71 <sup>C)</sup> -80 <sup>C)</sup> -90		35	
16.7	292	83.59	1.5	30/35/40					603C	80A4	63 <sup>B)</sup> -71-80-90	71 <sup>C)</sup> -80 <sup>C)</sup> -90	●	37
17.0	287	82.30	1.5	30/35/40				603A	80A4	63 <sup>B)</sup> -71-80-90	71 <sup>C)</sup> -80 <sup>C)</sup> -90		35	
17.0	287	82.30	1.5	30/35/40					603C	80A4	63 <sup>B)</sup> -71-80-90	71 <sup>C)</sup> -80 <sup>C)</sup> -90		37
18.3	268	76.69	1.3	28/30/35				503A	80A4	63 <sup>B)</sup> -71-80-90	71 <sup>C)</sup> -80 <sup>C)</sup> -90	●	33	
18.3	268	76.69	1.9	30/35/40				603A	80A4	63 <sup>B)</sup> -71-80-90	71 <sup>C)</sup> -80 <sup>C)</sup> -90	●	35	
18.3	268	76.69	1.9	30/35/40					603C	80A4	63 <sup>B)</sup> -71-80-90	71 <sup>C)</sup> -80 <sup>C)</sup> -90		37
19.7	248	71.01	1.8	30/35/40				603A	80A4	63 <sup>B)</sup> -71-80-90	71 <sup>C)</sup> -80 <sup>C)</sup> -90		35	
19.7	248	71.01	1.8	30/35/40					603C	80A4	63 <sup>B)</sup> -71-80-90	71 <sup>C)</sup> -80 <sup>C)</sup> -90	●	37
21.1	231	66.22	1.4	28/30/35				503A	80A4	63 <sup>B)</sup> -71-80-90	71 <sup>C)</sup> -80 <sup>C)</sup> -90		33	
21.1	231	66.22	2.2	30/35/40				603A	80A4	63 <sup>B)</sup> -71-80-90	71 <sup>C)</sup> -80 <sup>C)</sup> -90		35	
21.1	231	66.22	2.2	30/35/40					603C	80A4	63 <sup>B)</sup> -71-80-90	71 <sup>C)</sup> -80 <sup>C)</sup> -90		37
22.5	217	62.22	0.9	24/25					403C	80A4	63 <sup>B)</sup> -71-80-90	71 <sup>C)</sup> -80 <sup>C)</sup> -90		29
23.0	219	60.90	1.1	28/30/35				502A	80A4	71 <sup>B)</sup> -80-90-100/112	80-90-100/112		33	
23.0	219	60.90	1.2	28/30/35				452A	80A4	71 <sup>B)</sup> -80-90-100/112	80-90-100/112		31	
23.0	219	60.90	1.8	30/35/40				602A	80A4	71 <sup>B)</sup> -80-90-100/112	80-90-100/112		35	
23.0	219	60.90	2.0	30/35/40					602C	80A4	71 <sup>B)</sup> -80-90-100/112	80-90-100/112		37
24.5	199	57.13	2.5	30/35/40				603A	80A4	63 <sup>B)</sup> -71-80-90	71 <sup>C)</sup> -80 <sup>C)</sup> -90		35	
24.5	199	57.13	2.5	30/35/40					603C	80A4	63 <sup>B)</sup> -71-80-90	71 <sup>C)</sup> -80 <sup>C)</sup> -90		37
25.6	191	54.73	1.9	28/30/35				503A	80A4	63 <sup>B)</sup> -71-80-90	71 <sup>C)</sup> -80 <sup>C)</sup> -90	●	33	
25.6	191	54.73	2.6	30/35/40				603A	80A4	63 <sup>B)</sup> -71-80-90	71 <sup>C)</sup> -80 <sup>C)</sup> -90	●	35	
25.6	191	54.73	2.6	30/35/40					603C	80A4	63 <sup>B)</sup> -71-80-90	71 <sup>C)</sup> -80 <sup>C)</sup> -90		37
27.6	182	50.67	0.8	24/25					402C	80A4	63 <sup>B)</sup> -71-80-90	71 <sup>C)</sup> -80 <sup>C)</sup> -90		29
27.6	177	50.64	1.1	24/25					403C	80A4	63 <sup>B)</sup> -71-80-90	71 <sup>C)</sup> -80 <sup>C)</sup> -90	●	29
28.6	176	49.00	1.7	28/30/35				452A	80A4	71 <sup>B)</sup> -80-90-100/112	80-90-100/112		31	
28.6	176	49.00	1.8	28/30/35				502A	80A4	71 <sup>B)</sup> -80-90-100/112	80-90-100/112		33	
28.6	176	49.00	2.1	30/35/40				602A	80A4	71 <sup>B)</sup> -80-90-100/112	80-90-100/112		35	
28.6	176	49.00	2.1	30/35/40					602C	80A4	71 <sup>B)</sup> -80-90-100/112	80-90-100/112		37
29.6	165	47.22	2.1	28/30/35				503A	80A4	63 <sup>B)</sup> -71-80-90	71 <sup>C)</sup> -80 <sup>C)</sup> -90		33	
29.6	165	47.22	3.0	30/35/40				603A	80A4	63 <sup>B)</sup> -71-80-90	71 <sup>C)</sup> -80 <sup>C)</sup> -90		35	
29.6	165	47.22	3.0	30/35/40					603C	80A4	63 <sup>B)</sup> -71-80-90	71 <sup>C)</sup> -80 <sup>C)</sup> -90	●	37
29.9	169	46.87	1.0	24/25					402C	80A4	63 <sup>B)</sup> -71-80-90	71 <sup>C)</sup> -80 <sup>C)</sup> -90		29
29.9	169	46.86	0.8	24/25				402A	80A4	63 <sup>B)</sup> -71-80-90	71 <sup>C)</sup> -80 <sup>C)</sup> -90		27	
31.7	159	44.23	1.6	28/30/35				502A	80A4	71 <sup>B)</sup> -80-90-100/112	80-90-100/112		33	
31.7	159	44.23	2.5	30/35/40				602A	80A4	71 <sup>B)</sup> -80-90-100/112	80-90-100/112		35	
31.7	159	44.23	2.7	30/35/40					602C	80A4	71 <sup>B)</sup> -80-90-100/112	80-90-100/112		37
31.7	159	44.22	1.7	28/30/35				452A	80A4	71 <sup>B)</sup> -80-90-100/112	80-90-100/112		31	
32.0	152	43.69	1.3	24/25					403C	80A4	63 <sup>B)</sup> -71-80-90	71 <sup>C)</sup> -80 <sup>C)</sup> -90		29
34.6	146	40.50	2.0	28/30/35				452A	80A4	71 <sup>B)</sup> -80-90-100/112	80-90-100/112		31	
34.6	146	40.50	2.0	28/30/35				502A	80A4	71 <sup>B)</sup> -80-90-100/112	80-90-100/112		33	
34.6	146	40.50	2.1	30/35/40				602A	80A4	71 <sup>B)</sup> -80-90-100/112	80-90-100/112		35	
34.6	146	40.50	2.1	30/35/40					602C	80A4	71 <sup>B)</sup> -80-90-100/112	80-90-100/112		37
35.2	139	39.79	2.7	28/30/35				503A	80A4	63 <sup>B)</sup> -71-80-90	71 <sup>C)</sup> -80 <sup>C)</sup> -90		33	
36.5	138	38.37	1.2	24/25				402A	80A4	63 <sup>B)</sup> -71-80-90	71 <sup>C)</sup> -80 <sup>C)</sup> -90		27	
36.5	138	38.37	1.3	24/25					402C	80A4	63 <sup>B)</sup> -71-80-90	71 <sup>C)</sup> -80 <sup>C)</sup> -90		29
36.5	134	38.34	1.3	24/25					403C	80A4	63 <sup>B)</sup> -71-80-90	71 <sup>C)</sup> -80 <sup>C)</sup> -90	●	29
39.0	129	35.91	0.8	20				302A	80A4	63 <sup>B)</sup> -71-80-90	71 <sup>C)</sup> -80 <sup>C)</sup> -90		25	
39.0	129	35.91	1.1	24/25				402A	80A4	63 <sup>B)</sup> -71-80-90	71 <sup>C)</sup> -80 <sup>C)</sup> -90	●	27	
39.0	129	35.91	1.3	24/25					402C	80A4	63 <sup>B)</sup> -71-80-90	71 <sup>C)</sup> -80 <sup>C)</sup> -90	●	29
39.3	128	35.58	2.3	28/30/35				452A	80A4	71 <sup>B)</sup> -80-90-100/112	80-90-100/112		31	
39.3	128	35.58	2.5	28/30/35				502A	80A4	71 <sup>B)</sup> -80-90-100/112	80-90-100/112		33	

B

Монтируется с проставкой  
Coupling by means of reduction bushing



C

Положение отверстий моторного  
фланца редуктора  
Motor flange/terminal box position





**P<sub>1M</sub> = 0.55 kW**

1400 min<sup>-1</sup> (80A4)

n <sub>2</sub> [min <sup>-1</sup> ]	M <sub>2</sub> [Nm]	i	fs						1400 min <sup>-1</sup> (80A4)			
									B5	B14		
47.6	106	29.41	2.9	28/30/35								31
47.6	106	29.40	1.5	24/25								27
47.6	106	29.40	1.9	24/25								29
48.5	104	28.88	1.1	20						●		25
53	95	26.31	1.1	20								25
53	95	26.31	1.8	24/25						●		29
53	95	26.30	1.5	24/25						●		27
56	90	24.98	2.8	28/30/35						●		33
56	90	24.98	2.9	28/30/35						●		31
63	80	22.29	2.1	24/25								27
63	80	22.26	1.9	24/25								29
64	79	21.84	1.5	20								25
65	78	21.54	2.1	24/25						●		27
65	78	21.54	2.5	24/25						●		29
66	76	21.15	1.5	20						●		25
74	68	18.80	2.0	24/25								27
75	68	18.78	1.6	20								25
75	68	18.78	2.5	24/25								29
78	65	18.04	2.5	24/25								27
86	58	16.20	1.8	20								25
86	58	16.20	2.4	24/25								27
86	58	16.20	2.9	24/25								29
91	55	15.37	2.9	24/25						●		27
93	54	15.10	2.1	20						●		25
102	49	13.68	2.9	24/25								27
107	47	13.03	2.4	20								25
123	41	11.42	2.8	20								25
133	39	10.50	2.0	24/28	511							21
142	35	9.85	2.7	20						●		25
170	30	8.22	1.3	19/24	411							20
181	28	7.74	2.9	20								25
222	23	6.30	2.0	19/24	411							20
257	20	5.45	2.5	20						●		25
303	17	4.62	2.9	19/24	411							20
362	14	3.87	2.9	19/24	411							20
426	12	3.29	4.1	19/24	411							20
493	10	2.84	4.1	19/24	411							20

**P<sub>1M</sub> = 0.75 kW**

1400 min<sup>-1</sup> (80B4) - 900 min<sup>-1</sup> (90S6)

11.1	603	126.65	0.8	30/35/40						●		35
11.1	603	126.65	0.8	30/35/40								37
11.9	558	117.22	0.9	30/35/40								35
11.9	558	117.22	0.9	30/35/40						●		37
13.4	498	104.68	1.0	30/35/40						●		35
13.4	498	104.68	1.0	30/35/40								37
15.1	441	92.78	1.1	30/35/40								35
15.1	441	92.78	1.1	30/35/40								37
16.7	398	83.59	0.9	28/30/35								33
16.7	398	83.59	1.1	30/35/40								35
16.7	398	83.59	1.1	30/35/40						●		37
17.0	392	82.30	1.1	30/35/40								35
17.0	392	82.30	1.1	30/35/40								37
18.3	365	76.69	1.0	28/30/35						●		33
18.3	365	76.69	1.4	30/35/40						●		35

B

Монтируется с проставкой  
Coupling by means of reduction bushing



C

Положение отверстий моторного  
фланца редуктора  
Motor flange/terminal box position





**ВЫБОР МОТОР-РЕДУКТОРОВ / GEARMOTORS SELECTION / WAHL DES GETRIEBEMOTORS  
SELECTION DES MOTO-REDUCTEURS / SELECCIYN MOTO-REDUCTORES**

**P<sub>1M</sub> = 0.75 kW**

**1400 min<sup>-1</sup> (80B4) - 900 min<sup>-1</sup> (90S6)**

n <sub>2</sub> [min <sup>-1</sup> ]	M <sub>2</sub> [Nm]	i	fs										
									B5	B14			
18.3	365	76.69	1.4	30/35/40				603C	80B4	63 <sup>B)</sup> -71-80-90	71 <sup>C)</sup> -80 <sup>C)</sup> -90		37
19.7	338	71.01	1.3	30/35/40			603A	80B4	80B4	63 <sup>B)</sup> -71-80-90	71 <sup>C)</sup> -80 <sup>C)</sup> -90		35
19.7	338	71.01	1.3	30/35/40				603C	80B4	63 <sup>B)</sup> -71-80-90	71 <sup>C)</sup> -80 <sup>C)</sup> -90	●	37
21.1	315	66.22	1.0	28/30/35			503A	80B4	80B4	63 <sup>B)</sup> -71-80-90	71 <sup>C)</sup> -80 <sup>C)</sup> -90		33
21.1	315	66.22	1.6	30/35/40			603A	80B4	80B4	63 <sup>B)</sup> -71-80-90	71 <sup>C)</sup> -80 <sup>C)</sup> -90		35
21.1	315	66.22	1.6	30/35/40				603C	80B4	63 <sup>B)</sup> -71-80-90	71 <sup>C)</sup> -80 <sup>C)</sup> -90		37
23.0	299	60.90	0.8	28/30/35			502A	80B4	80B4	71 <sup>B)</sup> -80-90-100/112	80-90-100/112		33
23.0	299	60.90	0.9	28/30/35			452A	80B4	80B4	71 <sup>B)</sup> -80-90-100/112	80-90-100/112		31
23.0	299	60.90	1.3	30/35/40			602A	80B4	80B4	71 <sup>B)</sup> -80-90-100/112	80-90-100/112		35
23.0	299	60.90	1.5	30/35/40				602C	80B4	71 <sup>B)</sup> -80-90-100/112	80-90-100/112		37
24.5	272	57.13	1.8	30/35/40			603A	80B4	80B4	63 <sup>B)</sup> -71-80-90	71 <sup>C)</sup> -80 <sup>C)</sup> -90		35
24.5	272	57.13	1.8	30/35/40				603C	80B4	63 <sup>B)</sup> -71-80-90	71 <sup>C)</sup> -80 <sup>C)</sup> -90		37
25.6	260	54.73	1.4	28/30/35			503A	80B4	80B4	63 <sup>B)</sup> -71-80-90	71 <sup>C)</sup> -80 <sup>C)</sup> -90	●	33
25.6	260	54.73	1.9	30/35/40			603A	80B4	80B4	63 <sup>B)</sup> -71-80-90	71 <sup>C)</sup> -80 <sup>C)</sup> -90	●	35
25.6	260	54.73	1.9	30/35/40				603C	80B4	63 <sup>B)</sup> -71-80-90	71 <sup>C)</sup> -80 <sup>C)</sup> -90		37
27.6	241	50.64	0.8	24/25				403C	80B4	63 <sup>B)</sup> -71-80-90	71 <sup>C)</sup> -80 <sup>C)</sup> -90	●	29
28.6	241	49.00	1.2	28/30/35			452A	80B4	80B4	71 <sup>B)</sup> -80-90-100/112	80-90-100/112		31
28.6	241	49.00	1.4	28/30/35			502A	80B4	80B4	71 <sup>B)</sup> -80-90-100/112	80-90-100/112		33
28.6	241	49.00	1.5	30/35/40			602A	80B4	80B4	71 <sup>B)</sup> -80-90-100/112	80-90-100/112		35
28.6	241	49.00	1.5	30/35/40				602C	80B4	71 <sup>B)</sup> -80-90-100/112	80-90-100/112		37
29.6	225	47.22	1.6	28/30/35			503A	80B4	80B4	63 <sup>B)</sup> -71-80-90	71 <sup>C)</sup> -80 <sup>C)</sup> -90		33
29.6	225	47.22	2.2	30/35/40			603A	80B4	80B4	63 <sup>B)</sup> -71-80-90	71 <sup>C)</sup> -80 <sup>C)</sup> -90		35
29.6	225	47.22	2.2	30/35/40				603C	80B4	63 <sup>B)</sup> -71-80-90	71 <sup>C)</sup> -80 <sup>C)</sup> -90	●	37
31.7	217	44.23	1.2	28/30/35			502A	80B4	80B4	71 <sup>B)</sup> -80-90-100/112	80-90-100/112		33
31.7	217	44.23	1.8	30/35/40			602A	80B4	80B4	71 <sup>B)</sup> -80-90-100/112	80-90-100/112		35
31.7	217	44.23	2.0	30/35/40				602C	80B4	71 <sup>B)</sup> -80-90-100/112	80-90-100/112		37
31.7	217	44.22	1.2	28/30/35			452A	80B4	80B4	71 <sup>B)</sup> -80-90-100/112	80-90-100/112		31
32.0	208	43.69	0.9	24/25				403C	80B4	63 <sup>B)</sup> -71-80-90	71 <sup>C)</sup> -80 <sup>C)</sup> -90		29
34.6	199	40.50	1.5	28/30/35			452A	80B4	80B4	71 <sup>B)</sup> -80-90-100/112	80-90-100/112		31
34.6	199	40.50	1.5	28/30/35			502A	80B4	80B4	71 <sup>B)</sup> -80-90-100/112	80-90-100/112		33
34.6	199	40.50	1.6	30/35/40			602A	80B4	80B4	71 <sup>B)</sup> -80-90-100/112	80-90-100/112		35
34.6	199	40.50	1.6	30/35/40				602C	80B4	71 <sup>B)</sup> -80-90-100/112	80-90-100/112		37
35.2	189	39.79	2.0	28/30/35			503A	80B4	80B4	63 <sup>B)</sup> -71-80-90	71 <sup>C)</sup> -80 <sup>C)</sup> -90		33
35.2	189	39.79	2.3	30/35/40			603A	80B4	80B4	63 <sup>B)</sup> -71-80-90	71 <sup>C)</sup> -80 <sup>C)</sup> -90		35
35.2	189	39.79	2.3	30/35/40				603C	80B4	63 <sup>B)</sup> -71-80-90	71 <sup>C)</sup> -80 <sup>C)</sup> -90		37
36.5	188	38.37	0.8	24/25			402A	80B4	80B4	63 <sup>B)</sup> -71-80-90	71 <sup>C)</sup> -80 <sup>C)</sup> -90		27
36.5	188	38.37	1.0	24/25				402C	80B4	63 <sup>B)</sup> -71-80-90	71 <sup>C)</sup> -80 <sup>C)</sup> -90		29
36.5	182	38.34	1.0	24/25				403C	80B4	63 <sup>B)</sup> -71-80-90	71 <sup>C)</sup> -80 <sup>C)</sup> -90	●	29
39.0	176	35.91	1.0	24/25				402C	80B4	63 <sup>B)</sup> -71-80-90	71 <sup>C)</sup> -80 <sup>C)</sup> -90	●	29
39.3	175	35.58	1.7	28/30/35			452A	80B4	80B4	71 <sup>B)</sup> -80-90-100/112	80-90-100/112		31
39.3	175	35.58	1.9	28/30/35			502A	80B4	80B4	71 <sup>B)</sup> -80-90-100/112	80-90-100/112		33
39.3	175	35.58	2.9	30/35/40			602A	80B4	80B4	71 <sup>B)</sup> -80-90-100/112	80-90-100/112		35
39.3	175	35.58	2.9	30/35/40				602C	80B4	71 <sup>B)</sup> -80-90-100/112	80-90-100/112		37
47.6	144	29.41	2.1	28/30/35			452A	80B4	80B4	71 <sup>B)</sup> -80-90-100/112	80-90-100/112		31
47.6	144	29.41	2.5	28/30/35			502A	80B4	80B4	71 <sup>B)</sup> -80-90-100/112	80-90-100/112		33
47.6	144	29.41	3.0	30/35/40			602A	80B4	80B4	71 <sup>B)</sup> -80-90-100/112	80-90-100/112		35
47.6	144	29.41	3.0	30/35/40				602C	80B4	71 <sup>B)</sup> -80-90-100/112	80-90-100/112		37
47.6	144	29.40	1.1	24/25			402A	80B4	80B4	63 <sup>B)</sup> -71-80-90	71 <sup>C)</sup> -80 <sup>C)</sup> -90		27
47.6	144	29.40	1.4	24/25				402C	80B4	63 <sup>B)</sup> -71-80-90	71 <sup>C)</sup> -80 <sup>C)</sup> -90		29
48.5	142	28.88	0.8	20			302A	80B4	80B4	63 <sup>B)</sup> -71-80-90	71 <sup>C)</sup> -80 <sup>C)</sup> -90	●	25
53	129	26.31	0.8	20			302A	80B4	80B4	63 <sup>B)</sup> -71-80-90	71 <sup>C)</sup> -80 <sup>C)</sup> -90		25
53	129	26.31	1.3	24/25				402C	80B4	63 <sup>B)</sup> -71-80-90	71 <sup>C)</sup> -80 <sup>C)</sup> -90	●	29
53	129	26.30	1.1	24/25			402A	80B4	80B4	63 <sup>B)</sup> -71-80-90	71 <sup>C)</sup> -80 <sup>C)</sup> -90	●	27
56	123	24.98	2.0	28/30/35			502A	80B4	80B4	71 <sup>B)</sup> -80-90-100/112	80-90-100/112	●	33
56	123	24.98	2.2	28/30/35			452A	80B4	80B4	71 <sup>B)</sup> -80-90-100/112	80-90-100/112	●	31
57	121	24.61	2.7	28/30/35			502A	80B4	80B4	71 <sup>B)</sup> -80-90-100/112	80-90-100/112		33

**B**

Монтируется с проставкой  
Coupling by means of reduction bushing



**C**

Положение отверстий моторного  
фланца редуктора  
Motor flange/terminal box position







**P<sub>1M</sub> = 0.75 kW**

1400 min<sup>-1</sup> (80B4) - 900 min<sup>-1</sup> (90S6)

n <sub>2</sub> [min <sup>-1</sup> ]	M <sub>2</sub> [Nm]	i	fs						IEC			
									B5	B14		
63	109	22.29	1.5	24/25								27
63	109	22.26	1.4	24/25								29
64	107	21.84	1.1	20								25
65	106	21.54	1.5	24/25								27
65	106	21.54	1.9	24/25							●	29
66	104	21.15	1.1	20							●	25
70	99	20.10	3.0	28/30/35							●	31
74	92	18.80	1.5	24/25								27
75	92	18.78	1.2	20								25
75	92	18.78	1.8	24/25								29
78	89	18.04	1.8	24/25								27
86	80	16.20	1.3	20								25
86	80	16.20	1.7	24/25								27
86	80	16.20	2.1	24/25								29
91	75	15.37	2.1	24/25							●	27
91	75	15.37	2.6	24/25							●	29
93	74	15.10	1.5	20							●	25
102	67	13.68	2.1	24/25								27
106	65	13.26	2.5	24/25								27
106	65	13.26	2.8	24/25								29
107	64	13.03	1.8	20								25
120	57	11.66	3.0	24/25								27
120	57	11.64	2.8	24/25								29
133	53	10.50	1.5	24/28	511							21
139	49	10.06	3.0	24/25							●	27
139	49	10.04	3.0	24/25							●	29
142	48	9.85	2.0	20							●	25
165	42	5.45	1.2	20							●	25
170	41	8.22	0.9	19/24	411							20
181	38	7.74	2.1	20								25
184	38	7.63	3.0	24/28	511							21
194	35	7.20	2.0	20								25
220	31	6.36	3.0	24/25								27
222	32	6.30	1.5	19/24	411							20
225	31	6.23	2.3	20								25
257	27	5.45	1.9	20							●	25
303	23	4.62	2.1	19/24	411							20
327	21	4.28	2.4	20								25
362	19	3.87	2.1	19/24	411							20
407	17	3.44	3.0	20								25
426	16	3.29	3.0	19/24	411							20
493	14	2.84	3.0	19/24	411							20

**P<sub>1M</sub> = 1.1 kW**

1400 min<sup>-1</sup> (90S4)

18.3	535	76.69	0.9	30/35/40							●	35
18.3	535	76.69	0.9	30/35/40								37
19.7	496	71.01	0.9	30/35/40								35
19.7	496	71.01	0.9	30/35/40							●	37
21.1	462	66.22	1.1	30/35/40								35
21.1	462	66.22	1.1	30/35/40								37
23.0	439	60.90	0.9	30/35/40								35
23.0	439	60.90	1.0	30/35/40								37
24.5	399	57.13	1.3	30/35/40								35

B

Монтируется с проставкой  
Coupling by means of reduction bushing



C

Положение отверстий моторного  
фланца редуктора  
Motor flange/terminal box position





**ВЫБОР МОТОР-РЕДУКТОРОВ / GEARMOTORS SELECTION / WAHL DES GETRIEBEMOTORS  
SELECTION DES MOTO-REDUCTEURS / SELECCIYN MOTO-REDUCTORES**

**P<sub>1M</sub> = 1.1 kW**

**1400 min<sup>-1</sup> (90S4)**

n <sub>2</sub> [min <sup>-1</sup> ]	M <sub>2</sub> [Nm]	i	fs						1400 min <sup>-1</sup> (90S4)				
									B5	B14			
24.5	399	57.13	1.3	30/35/40				603C	90S4	63 <sup>B)</sup> -71-80-90	71 <sup>C)</sup> -80 <sup>C)</sup> -90	●	37
25.6	382	54.73	0.9	28/30/35			503A		90S4	63 <sup>B)</sup> -71-80-90	71 <sup>C)</sup> -80 <sup>C)</sup> -90	●	33
25.6	382	54.73	1.3	30/35/40			603A		90S4	63 <sup>B)</sup> -71-80-90	71 <sup>C)</sup> -80 <sup>C)</sup> -90	●	35
25.6	382	54.73	1.3	30/35/40				603C	90S4	63 <sup>B)</sup> -71-80-90	71 <sup>C)</sup> -80 <sup>C)</sup> -90		37
28.6	353	49.00	0.8	28/30/35			452A		90S4	71 <sup>B)</sup> -80-90-100/112	80-90-100/112		31
28.6	353	49.00	0.9	28/30/35			502A		90S4	71 <sup>B)</sup> -80-90-100/112	80-90-100/112		33
28.6	353	49.00	1.0	30/35/40			602A		90S4	71 <sup>B)</sup> -80-90-100/112	80-90-100/112		35
28.6	353	49.00	1.0	30/35/40				602C	90S4	71 <sup>B)</sup> -80-90-100/112	80-90-100/112		37
29.6	330	47.22	1.1	28/30/35			503A		90S4	63 <sup>B)</sup> -71-80-90	71 <sup>C)</sup> -80 <sup>C)</sup> -90		33
29.6	330	47.22	1.5	30/35/40			603A		90S4	63 <sup>B)</sup> -71-80-90	71 <sup>C)</sup> -80 <sup>C)</sup> -90		35
29.6	330	47.22	1.5	30/35/40				603C	90S4	63 <sup>B)</sup> -71-80-90	71 <sup>C)</sup> -80 <sup>C)</sup> -90	●	37
31.7	319	44.23	1.3	30/35/40			602A		90S4	71 <sup>B)</sup> -80-90-100/112	80-90-100/112		35
31.7	319	44.23	1.4	30/35/40				602C	90S4	71 <sup>B)</sup> -80-90-100/112	80-90-100/112		37
31.7	319	44.22	0.8	28/30/35			452A		90S4	71 <sup>B)</sup> -80-90-100/112	80-90-100/112		31
34.6	292	40.50	1.0	28/30/35			452A		90S4	71 <sup>B)</sup> -80-90-100/112	80-90-100/112		31
34.6	292	40.50	1.0	28/30/35			502A		90S4	71 <sup>B)</sup> -80-90-100/112	80-90-100/112		33
34.6	292	40.50	1.1	30/35/40			602A		90S4	71 <sup>B)</sup> -80-90-100/112	80-90-100/112		35
34.6	292	40.50	1.1	30/35/40				602C	90S4	71 <sup>B)</sup> -80-90-100/112	80-90-100/112		37
35.2	278	39.79	1.3	28/30/35			503A		90S4	63 <sup>B)</sup> -71-80-90	71 <sup>C)</sup> -80 <sup>C)</sup> -90		33
35.2	278	39.79	1.6	30/35/40			603A		90S4	63 <sup>B)</sup> -71-80-90	71 <sup>C)</sup> -80 <sup>C)</sup> -90		35
35.2	278	39.79	1.6	30/35/40				603C	90S4	63 <sup>B)</sup> -71-80-90	71 <sup>C)</sup> -80 <sup>C)</sup> -90		37
39.3	256	35.58	1.2	28/30/35			452A		90S4	71 <sup>B)</sup> -80-90-100/112	80-90-100/112		31
39.3	256	35.58	1.3	28/30/35			502A		90S4	71 <sup>B)</sup> -80-90-100/112	80-90-100/112		33
39.3	256	35.58	1.9	30/35/40			602A		90S4	71 <sup>B)</sup> -80-90-100/112	80-90-100/112		35
39.3	256	35.58	1.9	30/35/40				602C	90S4	71 <sup>B)</sup> -80-90-100/112	80-90-100/112		37
47.6	212	29.41	1.4	28/30/35			452A		90S4	71 <sup>B)</sup> -80-90-100/112	80-90-100/112		31
47.6	212	29.41	1.7	28/30/35			502A		90S4	71 <sup>B)</sup> -80-90-100/112	80-90-100/112		33
47.6	212	29.41	2.1	30/35/40			602A		90S4	71 <sup>B)</sup> -80-90-100/112	80-90-100/112		35
47.6	212	29.41	2.1	30/35/40				602C	90S4	71 <sup>B)</sup> -80-90-100/112	80-90-100/112		37
47.6	212	29.40	0.9	24/25				402C	90S4	63 <sup>B)</sup> -71-80-90	71 <sup>C)</sup> -80 <sup>C)</sup> -90		29
53	190	26.31	0.9	24/25				402C	90S4	63 <sup>B)</sup> -71-80-90	71 <sup>C)</sup> -80 <sup>C)</sup> -90	●	29
56	180	24.98	2.2	30/35/40			602A		90S4	71 <sup>B)</sup> -80-90-100/112	80-90-100/112	●	35
56	180	24.98	1.4	28/30/35			502A		90S4	71 <sup>B)</sup> -80-90-100/112	80-90-100/112	●	33
56	180	24.98	1.5	28/30/35			452A		90S4	71 <sup>B)</sup> -80-90-100/112	80-90-100/112	●	31
56	180	24.98	2.4	30/35/40				602C	90S4	71 <sup>B)</sup> -80-90-100/112	80-90-100/112	●	37
57	177	24.61	2.8	30/35/40			602A		90S4	71 <sup>B)</sup> -80-90-100/112	80-90-100/112	●	35
57	177	24.61	1.8	28/30/35			502A		90S4	71 <sup>B)</sup> -80-90-100/112	80-90-100/112		33
63	161	22.29	1.0	24/25			402A		90S4	63 <sup>B)</sup> -71-80-90	71 <sup>C)</sup> -80 <sup>C)</sup> -90		27
63	160	22.26	1.0	24/25				402C	90S4	63 <sup>B)</sup> -71-80-90	71 <sup>C)</sup> -80 <sup>C)</sup> -90		29
65	155	21.54	1.0	24/25			402A		90S4	63 <sup>B)</sup> -71-80-90	71 <sup>C)</sup> -80 <sup>C)</sup> -90	●	27
65	155	21.54	1.3	24/25				402C	90S4	63 <sup>B)</sup> -71-80-90	71 <sup>C)</sup> -80 <sup>C)</sup> -90	●	29
70	145	20.10	2.1	28/30/35			452A		90S4	71 <sup>B)</sup> -80-90-100/112	80-90-100/112	●	31
70	145	20.10	2.3	28/30/35			502A		90S4	71 <sup>B)</sup> -80-90-100/112	80-90-100/112	●	33
74	135	18.80	1.0	24/25			402A		90S4	63 <sup>B)</sup> -71-80-90	71 <sup>C)</sup> -80 <sup>C)</sup> -90		27
75	135	18.78	1.3	24/25				402C	90S4	63 <sup>B)</sup> -71-80-90	71 <sup>C)</sup> -80 <sup>C)</sup> -90		29
78	130	18.04	1.2	24/25			402A		90S4	63 <sup>B)</sup> -71-80-90	71 <sup>C)</sup> -80 <sup>C)</sup> -90		27
84	120	16.62	2.5	28/30/35			452A		90S4	71 <sup>B)</sup> -80-90-100/112	80-90-100/112	●	31
84	120	16.62	3.0	28/30/35			502A		90S4	71 <sup>B)</sup> -80-90-100/112	80-90-100/112	●	33
86	117	16.20	0.9	20			302A		90S4	63 <sup>B)</sup> -71-80-90	71 <sup>C)</sup> -80 <sup>C)</sup> -90		25
86	117	16.20	1.2	24/25			402A		90S4	63 <sup>B)</sup> -71-80-90	71 <sup>C)</sup> -80 <sup>C)</sup> -90		27
86	117	16.20	1.5	24/25				402C	90S4	63 <sup>B)</sup> -71-80-90	71 <sup>C)</sup> -80 <sup>C)</sup> -90		29
91	111	15.37	1.4	24/25			402A		90S4	63 <sup>B)</sup> -71-80-90	71 <sup>C)</sup> -80 <sup>C)</sup> -90	●	27
91	111	15.37	1.8	24/25				402C	90S4	63 <sup>B)</sup> -71-80-90	71 <sup>C)</sup> -80 <sup>C)</sup> -90	●	29
93	109	15.10	1.0	20			302A		90S4	63 <sup>B)</sup> -71-80-90	71 <sup>C)</sup> -80 <sup>C)</sup> -90	●	25
99	102	14.21	2.4	28/30/35			502A		90S4	71 <sup>B)</sup> -80-90-100/112	80-90-100/112		33
99	102	14.21	2.6	28/30/35			452A		90S4	71 <sup>B)</sup> -80-90-100/112	80-90-100/112		31

**B**

Монтируется с проставкой  
Coupling by means of reduction bushing



**C**

Положение отверстий моторного  
фланца редуктора  
Motor flange/terminal box position







**P<sub>1M</sub> = 1.1 kW**

**1400 min<sup>-1</sup> (90S4)**

n <sub>2</sub> [min <sup>-1</sup> ]	M <sub>2</sub> [Nm]	i	fs								
								B5	B14		
102	99	13.68	1.5	24/25				63 <sup>B</sup> -71-80-90	71 <sup>C</sup> -80 <sup>C</sup> -90		27
106	96	13.26	1.7	24/25				63 <sup>B</sup> -71-80-90	71 <sup>C</sup> -80 <sup>C</sup> -90-100/112		27
106	96	13.26	1.9	24/25			402C	63 <sup>B</sup> -71-80-90	71 <sup>C</sup> -80 <sup>C</sup> -90-100/112		29
107	94	13.03	1.2	20				63 <sup>B</sup> -71-80-90	71 <sup>C</sup> -80 <sup>C</sup> -90		25
120	84	11.66	2.1	24/25				63 <sup>B</sup> -71-80-90	71 <sup>C</sup> -80 <sup>C</sup> -90-100/112		27
120	84	11.64	1.9	24/25			402C	63 <sup>B</sup> -71-80-90	71 <sup>C</sup> -80 <sup>C</sup> -90-100/112		29
123	82	11.42	1.4	20				63 <sup>B</sup> -71-80-90	71 <sup>C</sup> -80 <sup>C</sup> -90		25
133	77	10.50	1.0	24/28	511			71 <sup>B</sup> -80-90-100/112	80-90-100/112		21
139	72	10.06	2.1	24/25				63 <sup>B</sup> -71-80-90	71 <sup>C</sup> -80 <sup>C</sup> -90-100/112	●	27
139	72	10.04	2.1	24/25			402C	63 <sup>B</sup> -71-80-90	71 <sup>C</sup> -80 <sup>C</sup> -90-100/112	●	29
142	71	9.85	1.3	20				63 <sup>B</sup> -71-80-90	71 <sup>C</sup> -80 <sup>C</sup> -90	●	25
156	65	8.96	2.5	24/25				63 <sup>B</sup> -71-80-90	71 <sup>C</sup> -80 <sup>C</sup> -90-100/112		29
181	56	7.74	1.4	20				63 <sup>B</sup> -71-80-90	71 <sup>C</sup> -80 <sup>C</sup> -90		25
184	56	7.63	2.0	24/28	511			71 <sup>B</sup> -80-90-100/112	80-90-100/112		21
191	53	7.33	2.3	24/25				63 <sup>B</sup> -71-80-90	71 <sup>C</sup> -80 <sup>C</sup> -90-100/112		27
191	53	7.33	2.8	24/25			402C	63 <sup>B</sup> -71-80-90	71 <sup>C</sup> -80 <sup>C</sup> -90-100/112		29
194	52	7.20	1.3	20				63 <sup>B</sup> -71-80-90	71 <sup>C</sup> -80 <sup>C</sup> -90		25
220	46	6.36	2.1	24/25				63 <sup>B</sup> -71-80-90	71 <sup>C</sup> -80 <sup>C</sup> -90-100/112		27
222	46	6.30	1.0	19/24	411			63 <sup>B</sup> -71 <sup>B</sup> -80-90	71 <sup>B</sup> -80 <sup>C</sup> -90		20
225	45	6.23	1.6	20				63 <sup>B</sup> -71-80-90	71 <sup>C</sup> -80 <sup>C</sup> -90		25
252	40	5.55	2.5	24/25				63 <sup>B</sup> -71-80-90	71 <sup>C</sup> -80 <sup>C</sup> -90-100/112	●	27
252	40	5.55	3.0	24/25			402C	63 <sup>B</sup> -71-80-90	71 <sup>C</sup> -80 <sup>C</sup> -90-100/112	●	29
257	39	5.45	1.3	20				63 <sup>B</sup> -71-80-90	71 <sup>C</sup> -80 <sup>C</sup> -90	●	25
303	34	4.62	1.4	19/24	411			63 <sup>B</sup> -71 <sup>B</sup> -80-90	71 <sup>B</sup> -80 <sup>C</sup> -90		20
320	31	4.37	2.9	24/25				63 <sup>B</sup> -71-80-90	71 <sup>C</sup> -80 <sup>C</sup> -90-100/112		27
327	31	4.28	1.6	20				63 <sup>B</sup> -71-80-90	71 <sup>C</sup> -80 <sup>C</sup> -90		25
362	28	3.87	1.4	19/24	411			63 <sup>B</sup> -71 <sup>B</sup> -80-90	71 <sup>B</sup> -80 <sup>C</sup> -90		20
407	25	3.44	2.0	20				63 <sup>B</sup> -71-80-90	71 <sup>C</sup> -80-90		25
426	24	3.29	2.0	19/24	411			63 <sup>B</sup> -71 <sup>B</sup> -80-90	71 <sup>B</sup> -80 <sup>C</sup> -90		20
493	21	2.84	2.0	19/24	411			63 <sup>B</sup> -71 <sup>B</sup> -80-90	71 <sup>B</sup> -80 <sup>C</sup> -90		20

**P<sub>1M</sub> = 1.5 kW**

**1400 min<sup>-1</sup> (90LA4)**

24.5	544	57.13	0.9	30/35/40		603A		90LA4	63 <sup>B</sup> -71-80-90	71 <sup>C</sup> -80 <sup>C</sup> -90		35
24.5	544	57.13	0.9	30/35/40			603C	90LA4	63 <sup>B</sup> -71-80-90	71 <sup>C</sup> -80 <sup>C</sup> -90		37
25.6	521	54.73	1.0	30/35/40		603A		90LA4	63 <sup>B</sup> -71-80-90	71 <sup>C</sup> -80 <sup>C</sup> -90	●	35
25.6	521	54.73	1.0	30/35/40			603C	90LA4	63 <sup>B</sup> -71-80-90	71 <sup>C</sup> -80 <sup>C</sup> -90		37
29.6	449	47.22	1.1	30/35/40		603A		90LA4	63 <sup>B</sup> -71-80-90	71 <sup>C</sup> -80 <sup>C</sup> -90		35
29.6	449	47.22	1.1	30/35/40			603C	90LA4	63 <sup>B</sup> -71-80-90	71 <sup>C</sup> -80 <sup>C</sup> -90	●	37
31.7	434	44.23	0.9	30/35/40		602A		90LA4	71 <sup>B</sup> -80-90-100/112	80-90-100/112		35
31.7	434	44.23	1.0	30/35/40			602C	90LA4	71 <sup>B</sup> -80-90-100/112	80-90-100/112		37
35.2	379	39.79	1.0	28/30/35		503A		90LA4	63 <sup>B</sup> -71-80-90	71 <sup>C</sup> -80 <sup>C</sup> -90		33
35.2	379	39.79	1.1	30/35/40		603A		90LA4	63 <sup>B</sup> -71-80-90	71 <sup>C</sup> -80 <sup>C</sup> -90		35
35.2	379	39.79	1.1	30/35/40			603C	90LA4	63 <sup>B</sup> -71-80-90	71 <sup>C</sup> -80 <sup>C</sup> -90		37
39.3	349	35.58	0.9	28/30/35		452A		90LA4	71-80-90-100/112	80-90-100/112		31
39.3	349	35.58	0.9	28/30/35		502A		90LA4	71 <sup>B</sup> -80-90-100/112	80-90-100/112		33
39.3	349	35.58	1.4	30/35/40		602A		90LA4	71 <sup>B</sup> -80-90-100/112	80-90-100/112		35
39.3	349	35.58	1.4	30/35/40			602C	90LA4	71 <sup>B</sup> -80-90-100/112	80-90-100/112		37
47.6	289	29.41	1.1	28/30/35		452A		90LA4	71 <sup>B</sup> -80-90-100/112	80-90-100/112		31
47.6	289	29.41	1.2	28/30/35		502A		90LA4	71 <sup>B</sup> -80-90-100/112	80-90-100/112		33
47.6	289	29.41	1.5	30/35/40		602A		90LA4	71 <sup>B</sup> -80-90-100/112	80-90-100/112		35
47.6	289	29.41	1.5	30/35/40			602C	90LA4	71 <sup>B</sup> -80-90-100/112	80-90-100/112		37
56	245	24.98	1.6	30/35/40		602A		90LA4	71 <sup>B</sup> -80-90-100/112	80-90-100/112	●	35
56	245	24.98	1.0	28/30/35		502A		90LA4	71 <sup>B</sup> -80-90-100/112	80-90-100/112	●	33
56	245	24.98	1.1	28/30/35		452A		90LA4	71 <sup>B</sup> -80-90-100/112	80-90-100/112	●	31

B

Монтируется с проставкой  
Coupling by means of reduction bushing



C

Положение отверстий моторного  
фланца редуктора  
Motor flange/terminal box position





ВЫБОР МОТОР-РЕДУКТОРОВ / GEARMOTORS SELECTION / WAHL DES GETRIEBEMOTORS  
SELECTION DES MOTO-REDUCTEURS / SELECCIYN MOTO-REDUCTORES

$P_{1M} = 1.5 \text{ kW}$

1400 min<sup>-1</sup> (90LA4)

n <sub>2</sub> [min <sup>-1</sup> ]	M <sub>2</sub> [Nm]	i	fs						1400 min <sup>-1</sup> (90LA4)				
									B5	B14			
56	245	24.98	1.8	30/35/40				602C	90LA4	71 <sup>B</sup> -80-90-100/112	80-90-100/112	●	37
57	242	24.61	2.0	30/35/40			602A		90LA4	71 <sup>B</sup> -80-90-100/112	80-90-100/112	●	35
57	242	24.61	1.3	28/30/35			502A		90LA4	71 <sup>B</sup> -80-90-100/112	80-90-100/112		33
65	212	21.54	0.9	24/25				402C	90LA4	63 <sup>B</sup> -71-80-90	71 <sup>C</sup> -80 <sup>C</sup> -90	●	29
70	197	20.10	1.5	28/30/35			452A		90LA4	71 <sup>B</sup> -80-90-100/112	80-90-100/112	●	31
70	197	20.10	1.7	28/30/35			502A		90LA4	71 <sup>B</sup> -80-90-100/112	80-90-100/112	●	33
70	197	20.10	2.5	30/35/40			602A		90LA4	71 <sup>B</sup> -80-90-100/112	80-90-100/112		35
70	197	20.10	2.5	30/35/40				602C	90LA4	71 <sup>B</sup> -80-90-100/112	80-90-100/112	●	37
75	184	18.78	0.9	24/25				402C	90LA4	63 <sup>B</sup> -71-80-90	71 <sup>C</sup> -80 <sup>C</sup> -90		29
78	177	18.04	0.9	24/25			402A		90LA4	63 <sup>B</sup> -71-80-90	71 <sup>C</sup> -80 <sup>C</sup> -90		27
84	163	16.62	1.9	28/30/35			452A		90LA4	71 <sup>B</sup> -80-90-100/112	80-90-100/112	●	31
84	163	16.62	2.2	28/30/35			502A		90LA4	71 <sup>B</sup> -80-90-100/112	80-90-100/112	●	33
86	159	16.20	0.9	24/25			402A		90LA4	63 <sup>B</sup> -71-80-90	71 <sup>C</sup> -80 <sup>C</sup> -90		27
86	159	16.20	1.1	24/25				402C	90LA4	63 <sup>B</sup> -71-80-90	71 <sup>C</sup> -80 <sup>C</sup> -90		29
91	151	15.37	1.1	24/25			402A		90LA4	63 <sup>B</sup> -71-80-90	71 <sup>C</sup> -80 <sup>C</sup> -90	●	27
91	151	15.37	1.3	24/25				402C	90LA4	63 <sup>B</sup> -71-80-90	71 <sup>C</sup> -80 <sup>C</sup> -90	●	29
99	140	14.21	1.8	28/30/35			502A		90LA4	71 <sup>B</sup> -80-90-100/112	80-90-100/112		33
99	140	14.21	1.9	28/30/35			452A		90LA4	71 <sup>B</sup> -80-90-100/112	80-90-100/112		31
99	140	14.21	2.9	30/35/40			602A		90LA4	71 <sup>B</sup> -80-90-100/112	80-90-100/112		35
102	134	13.68	1.1	24/25			402A		90LA4	63-71-80-90	71 <sup>C</sup> -80 <sup>C</sup> -90		27
106	130	13.26	1.2	24/25			402A		90LA4	63 <sup>B</sup> -71-80-90	71 <sup>C</sup> -80 <sup>C</sup> -90-100/112		27
106	130	13.26	1.4	24/25				402C	90LA4	63 <sup>B</sup> -71-80-90	71 <sup>C</sup> -80 <sup>C</sup> -90-100/112		29
107	128	13.03	0.9	20			302A		90LA4	63 <sup>B</sup> -71-80-90	71 <sup>C</sup> -80 <sup>C</sup> -90		25
120	114	11.66	1.5	24/25			402A		90LA4	63 <sup>B</sup> -71-80-90	71 <sup>C</sup> -80 <sup>C</sup> -90-100/112		27
120	114	11.64	1.4	24/25				402C	90LA4	63 <sup>B</sup> -71-80-90	71 <sup>C</sup> -80 <sup>C</sup> -90-100/112		29
122	112	11.43	2.7	28/30/35			452A		90LA4	71 <sup>B</sup> -80-90-100/112	80-90-100/112-132		31
122	112	11.43	2.9	28/30/35			502A		90LA4	71 <sup>B</sup> -80-90-100/112	80-90-100/112		33
123	112	11.42	1.0	20			302A		90LA4	63 <sup>B</sup> -71-80-90	71 <sup>C</sup> -80 <sup>C</sup> -90		25
139	99	10.06	1.5	24/25			402A		90LA4	63 <sup>B</sup> -71-80-90	71 <sup>C</sup> -80 <sup>C</sup> -90-100/112	●	27
139	99	10.04	1.5	24/25				402C	90LA4	63 <sup>B</sup> -71-80-90	71 <sup>C</sup> -80 <sup>C</sup> -90-100/112	●	29
142	97	9.85	1.0	20			302A		90LA4	63 <sup>B</sup> -71-80-90	71 <sup>C</sup> -80 <sup>C</sup> -90	●	25
156	88	8.96	1.8	24/25				402C	90LA4	63 <sup>B</sup> -71-80-90	71 <sup>C</sup> -80 <sup>C</sup> -90-100/112		29
177	78	7.89	1.5	24/25			402A		90LA4	63 <sup>B</sup> -71-80-90	71 <sup>C</sup> -80 <sup>C</sup> -90-100/112		27
181	76	7.74	1.1	20			302A		90LA4	63 <sup>B</sup> -71-80-90	71 <sup>C</sup> -80 <sup>C</sup> -90		25
184	76	7.63	1.5	24/28	511				90LA4	71 <sup>B</sup> -80-90-100/112	80-90-100/112		21
191	72	7.33	1.7	24/25			402A		90LA4	63 <sup>B</sup> -71-80-90	71 <sup>C</sup> -80 <sup>C</sup> -90-100/112		27
191	72	7.33	2.1	24/25				402C	90LA4	63 <sup>B</sup> -71-80-90	71 <sup>C</sup> -80 <sup>C</sup> -90-100/112		29
194	71	7.20	1.0	20			302A		90LA4	63 <sup>B</sup> -71-80-90	71 <sup>C</sup> -80 <sup>C</sup> -90		25
220	62	6.36	1.5	24/25			402A		90LA4	63 <sup>B</sup> -71-80-90	71 <sup>C</sup> -80 <sup>C</sup> -90-100/112		27
225	61	6.23	1.1	20			302A		90LA4	63 <sup>B</sup> -71-80-90	71 <sup>C</sup> -80 <sup>C</sup> -90		25
252	55	5.55	1.8	24/25			402A		90LA4	63 <sup>B</sup> -71-80-90	71 <sup>C</sup> -80 <sup>C</sup> -90-100/112	●	27
252	55	5.55	2.2	24/25				402C	90LA4	63 <sup>B</sup> -71-80-90	71 <sup>C</sup> -80 <sup>C</sup> -90-100/112	●	29
257	54	5.45	0.9	20			302A		90LA4	63 <sup>B</sup> -71-80-90	71 <sup>C</sup> -80 <sup>C</sup> -90	●	25
266	53	5.27	2.5	24/28	511				90LA4	71 <sup>B</sup> -80-90-100/112	80-90-100/112		21
303	46	4.62	1.0	19/24	411				90LA4	63 <sup>B</sup> -71 <sup>B</sup> -80-90	71 <sup>B</sup> <sup>C</sup> -80 <sup>C</sup> -90		20
320	43	4.37	2.1	24/25			402A		90LA4	63 <sup>B</sup> -71-80-90	71 <sup>C</sup> -80 <sup>C</sup> -90-100/112		27
327	42	4.28	1.2	20			302A		90LA4	63 <sup>B</sup> -71-80-90	71 <sup>C</sup> -80 <sup>C</sup> -90		25
362	39	3.87	1.0	19/24	411				90LA4	63 <sup>B</sup> -71 <sup>B</sup> -80-90	71 <sup>B</sup> <sup>C</sup> -80 <sup>C</sup> -90		20
398	35	3.52	2.3	24/25			402A		90LA4	63 <sup>B</sup> -71-80-90	71 <sup>C</sup> -80 <sup>C</sup> -90-100/112		27
407	34	3.44	1.5	20			302A		90LA4	63 <sup>B</sup> -71-80-90	71 <sup>C</sup> -80 <sup>C</sup> -90		25
426	33	3.29	1.5	19/24	411				90LA4	63 <sup>B</sup> -71 <sup>B</sup> -80-90	71 <sup>B</sup> <sup>C</sup> -80 <sup>C</sup> -90		20
493	28	2.84	1.5	19/24	411				90LA4	63 <sup>B</sup> -71 <sup>B</sup> -80-90	71 <sup>B</sup> <sup>C</sup> -80 <sup>C</sup> -90		20
892	16	1.57	2.6	19/24	411				90LA4	63 <sup>B</sup> -71 <sup>B</sup> -80-90	71 <sup>B</sup> <sup>C</sup> -80 <sup>C</sup> -90		20

B

Монтируется с проставкой  
Coupling by means of reduction bushing



C

Положение отверстий моторного  
фланца редуктора  
Motor flange/terminal box position





**P<sub>1M</sub> = 1.8 kW**

**1400 min<sup>-1</sup> (90LB4)**

n <sub>2</sub> [min <sup>-1</sup> ]	M <sub>2</sub> [Nm]	i	fs						1400 min <sup>-1</sup> (90LB4)						
									B5	B14					
29.6	554	47.22	0.9	30/35/40					603A	90LB4	63 <sup>B</sup> -71-80-90	71 <sup>C</sup> -80 <sup>C</sup> -90	●	35	
29.6	554	47.22	0.9	30/35/40						603C	90LB4	63 <sup>B</sup> -71-80-90	71 <sup>C</sup> -80 <sup>C</sup> -90	●	37
31.7	536	44.23	0.8	30/35/40						602C	90LB4	71 <sup>B</sup> -80-90-100/112	80-90-100/112		37
35.2	467	39.79	0.9	30/35/40					603A	90LB4	63 <sup>B</sup> -71-80-90	71 <sup>C</sup> -80 <sup>C</sup> -90		35	
35.2	467	39.79	0.9	30/35/40						603C	90LB4	63 <sup>B</sup> -71-80-90	71 <sup>C</sup> -80 <sup>C</sup> -90		37
39.3	431	35.58	1.2	30/35/40					602A	90LB4	71 <sup>B</sup> -80-90-100/112	80-90-100/112		35	
39.3	431	35.58	1.2	30/35/40						602C	90LB4	71 <sup>B</sup> -80-90-100/112	80-90-100/112		37
47.6	356	29.41	0.9	28/30/35					452A	90LB4	71 <sup>B</sup> -80-90-100/112	80-90-100/112		31	
47.6	356	29.41	1.0	28/30/35					502A	90LB4	71 <sup>B</sup> -80-90-100/112	80-90-100/112		33	
47.6	356	29.41	1.2	30/35/40					602A	90LB4	71 <sup>B</sup> -80-90-100/112	80-90-100/112		35	
47.6	356	29.41	1.2	30/35/40						602C	90LB4	71 <sup>B</sup> -80-90-100/112	80-90-100/112		37
56	303	24.98	1.3	30/35/40					602A	90LB4	71 <sup>B</sup> -80-90-100/112	80-90-100/112	●	35	
56	303	24.98	0.8	28/30/35					502A	90LB4	71 <sup>B</sup> -80-90-100/112	80-90-100/112	●	33	
56	303	24.98	0.9	28/30/35					452A	90LB4	71 <sup>B</sup> -80-90-100/112	80-90-100/112	●	31	
56	303	24.98	1.4	30/35/40						602C	90LB4	71 <sup>B</sup> -80-90-100/112	80-90-100/112	●	37
57	298	24.61	1.7	30/35/40					602A	90LB4	71 <sup>B</sup> -80-90-100/112	80-90-100/112	●	35	
57	298	24.61	1.1	28/30/35					502A	90LB4	71 <sup>B</sup> -80-90-100/112	80-90-100/112		33	
70	244	20.10	1.2	28/30/35					452A	90LB4	71 <sup>B</sup> -80-90-100/112	80-90-100/112	●	31	
70	244	20.10	1.3	28/30/35					502A	90LB4	71 <sup>B</sup> -80-90-100/112	80-90-100/112	●	33	
70	244	20.10	2.0	30/35/40					602A	90LB4	71 <sup>B</sup> -80-90-100/112	80-90-100/112		35	
70	244	20.10	2.0	30/35/40						602C	90LB4	71 <sup>B</sup> -80-90-100/112	80-90-100/112	●	37
84	201	16.62	1.5	28/30/35					452A	90LB4	71 <sup>B</sup> -80-90-100/112	80-90-100/112	●	31	
84	201	16.62	1.8	28/30/35					502A	90LB4	71 <sup>B</sup> -80-90-100/112	80-90-100/112	●	33	
84	201	16.62	2.5	30/35/40					602A	90LB4	71 <sup>B</sup> -80-90-100/112	80-90-100/112	●	35	
84	201	16.62	2.5	30/35/40						602C	90LB4	71 <sup>B</sup> -80-90-100/112	80-90-100/112	●	37
86	196	16.20	0.9	24/25						402C	90LB4	63 <sup>B</sup> -71-80-90	71 <sup>C</sup> -80 <sup>C</sup> -90		29
91	186	15.37	0.9	24/25					402A	90LB4	63 <sup>B</sup> -71-80-90	71 <sup>C</sup> -80 <sup>C</sup> -90	●	27	
91	186	15.37	1.1	24/25						402C	90LB4	63 <sup>B</sup> -71-80-90	71 <sup>C</sup> -80 <sup>C</sup> -90	●	29
99	172	14.21	1.5	28/30/35					502A	90LB4	71 <sup>B</sup> -80-90-100/112	80-90-100/112		33	
99	172	14.21	1.5	28/30/35					452A	90LB4	71 <sup>B</sup> -80-90-100/112	80-90-100/112		31	
99	172	14.21	2.3	30/35/40					602A	90LB4	71 <sup>B</sup> -80-90-100/112	80-90-100/112		35	
99	172	14.21	2.5	30/35/40						602C	90LB4	71 <sup>B</sup> -80-90-100/112	80-90-100/112		37
102	166	13.68	0.9	24/25					402A	90LB4	63 <sup>B</sup> -71-80-90	71 <sup>C</sup> -80 <sup>C</sup> -90		27	
106	161	13.26	1.0	24/25					402A	90LB4	63 <sup>B</sup> -71-80-90	71 <sup>C</sup> -80 <sup>C</sup> -90-100/112		27	
106	161	13.26	1.1	24/25						402C	90LB4	63 <sup>B</sup> -71-80-90	71 <sup>C</sup> -80 <sup>C</sup> -90-100/112		29
120	141	11.66	1.2	24/25					402A	90LB4	63 <sup>B</sup> -71-80-90	71 <sup>C</sup> -80 <sup>C</sup> -90-100/112		27	
120	141	11.64	1.1	24/25						402C	90LB4	63 <sup>B</sup> -71-80-90	71 <sup>C</sup> -80 <sup>C</sup> -90-100/112		29
122	138	11.43	2.2	28/30/35					452A	90LB4	71 <sup>B</sup> -80-90-100/112	80-90-100/112-132		31	
122	138	11.43	2.4	28/30/35					502A	90LB4	71 <sup>B</sup> -80-90-100/112	80-90-100/112		33	
122	138	11.43	2.9	30/35/40					602A	90LB4	71 <sup>B</sup> -80-90-100/112	80-90-100/112-132		35	
122	138	11.43	2.9	30/35/40						602C	90LB4	71 <sup>B</sup> -80-90-100/112	80-90-100/112-132		37
123	138	11.42	0.8	20					302A	90LB4	63 <sup>B</sup> -71-80-90	71 <sup>C</sup> -80 <sup>C</sup> -90		25	
139	122	10.06	1.2	24/25					402A	90LB4	63 <sup>B</sup> -71-80-90	71 <sup>C</sup> -80 <sup>C</sup> -90-100/112	●	27	
139	122	10.04	1.2	24/25						402C	90LB4	63 <sup>B</sup> -71-80-90	71 <sup>C</sup> -80 <sup>C</sup> -90-100/112	●	29
148	114	9.45	2.7	28/30/35					452A	90LB4	71 <sup>B</sup> -80-90-100/112	80-90-100/112-132	●	31	
156	109	8.96	1.5	24/25						402C	90LB4	63 <sup>B</sup> -71-80-90	71 <sup>C</sup> -80 <sup>C</sup> -90-100/112		29
177	96	7.89	1.3	24/25					402A	90LB4	63 <sup>B</sup> -71-80-90	71 <sup>C</sup> -80 <sup>C</sup> -90-100/112		27	
181	94	7.74	0.9	20					302A	90LB4	63 <sup>B</sup> -71-80-90	71 <sup>C</sup> -80 <sup>C</sup> -90		25	
184	94	7.63	1.2	24/28	511					90LB4	71 <sup>B</sup> -80-90-100/112	80-90-100/112		21	
191	89	7.33	1.4	24/25					402A	90LB4	63 <sup>B</sup> -71-80-90	71 <sup>C</sup> -80 <sup>C</sup> -90-100/112		27	
191	89	7.33	1.7	24/25						402C	90LB4	63 <sup>B</sup> -71-80-90	71 <sup>C</sup> -80 <sup>C</sup> -90-100/112		29
194	87	7.20	0.8	20					302A	90LB4	63 <sup>B</sup> -71-80-90	71 <sup>C</sup> -80 <sup>C</sup> -90		25	
220	77	6.36	1.2	24/25					402A	90LB4	63 <sup>B</sup> -71-80-90	71 <sup>C</sup> -80 <sup>C</sup> -90-100/112		27	
225	75	6.23	0.9	20					302A	90LB4	63 <sup>B</sup> -71-80-90	71 <sup>C</sup> -80 <sup>C</sup> -90		25	
252	67	5.55	1.5	24/25					402A	90LB4	63 <sup>B</sup> -71-80-90	71 <sup>C</sup> -80 <sup>C</sup> -90-100/112	●	27	
252	67	5.55	1.8	24/25						402C	90LB4	63 <sup>B</sup> -71-80-90	71 <sup>C</sup> -80 <sup>C</sup> -90-100/112	●	29

**B**

Монтируется с проставкой  
Coupling by means of reduction bushing



**C**

Положение отверстий моторного  
фланца редуктора  
Motor flange/terminal box position





ВЫБОР МОТОР-РЕДУКТОРОВ / GEARMOTORS SELECTION / WAHL DES GETRIEBEMOTORS  
SELECTION DES MOTO-REDUCTEURS / SELECCIYN MOTO-REDUCTORES

**P<sub>1M</sub> = 1.8 kW**

**1400 min<sup>-1</sup> (90LB4)**

n <sub>2</sub> [min <sup>-1</sup> ]	M <sub>2</sub> [Nm]	i	fs						1400 min <sup>-1</sup> (90LB4)			
									B5	B14		
266	65	5.27	2.0	24/28	511			90LB4	71 <sup>B</sup> -80-90-100/112	80-90-100/112		21
303	57	4.62	0.8	19/24	411			90LB4	63 <sup>B</sup> -71 <sup>B</sup> -80-90	71 <sup>B</sup> <sup>C</sup> -80 <sup>C</sup> -90		20
320	53	4.37	1.7	24/25		402A		90LB4	63 <sup>B</sup> -71-80-90	71 <sup>C</sup> -80 <sup>C</sup> -90-100/112		27
325	53	4.31	2.5	24/28	511			90LB4	71 <sup>B</sup> -80-90-100/112	80-90-100/112		21
327	52	4.28	1.0	20		302A		90LB4	63 <sup>B</sup> -71-80-90	71 <sup>C</sup> -80 <sup>C</sup> -90		25
362	48	3.87	0.8	19/24	411			90LB4	63 <sup>B</sup> -71 <sup>B</sup> -80-90	71 <sup>B</sup> <sup>C</sup> -80 <sup>C</sup> -90		20
398	43	3.52	1.9	24/25		402A		90LB4	63 <sup>B</sup> -71-80-90	71 <sup>C</sup> -80 <sup>C</sup> -90-100/112		27
407	42	3.44	1.2	20		302A		90LB4	63 <sup>B</sup> -71-80-90	71 <sup>C</sup> -80 <sup>C</sup> -90		25
423	41	3.31	3.0	24/28	511			90LB4	71 <sup>B</sup> -80-90-100/112	80-90-100/112		21
426	41	3.29	1.2	19/24	411			90LB4	63 <sup>B</sup> -71 <sup>B</sup> -80-90	71 <sup>B</sup> <sup>C</sup> -80 <sup>C</sup> -90		20
493	35	2.84	1.2	19/24	411			90LB4	63 <sup>B</sup> -71 <sup>B</sup> -80-90	71 <sup>B</sup> <sup>C</sup> -80 <sup>C</sup> -90		20
892	19	1.57	2.1	19/24	411			90LB4	63 <sup>B</sup> -71 <sup>B</sup> -80-90	71 <sup>B</sup> <sup>C</sup> -80 <sup>C</sup> -90		20

**P<sub>1M</sub> = 2.2 kW**

**1400 min<sup>-1</sup> (100LA4)**

39.3	513	35.58	1.0	30/35/40		602A		100LA4	71 <sup>B</sup> -80-90-100/112	80-90-100/112		35
39.3	513	35.58	1.0	30/35/40			602C	100LA4	71 <sup>B</sup> -80-90-100/112	80-90-100/112		37
47.6	424	29.41	0.8	28/30/35		502A		100LA4	71 <sup>B</sup> -80-90-100/112	80-90-100/112		33
47.6	424	29.41	1.0	30/35/40		602A		100LA4	71 <sup>B</sup> -80-90-100/112	80-90-100/112		35
47.6	424	29.41	1.0	30/35/40			602C	100LA4	71 <sup>B</sup> -80-90-100/112	80-90-100/112		37
56	360	24.98	1.1	30/35/40		602A		100LA4	71 <sup>B</sup> -80-90-100/112	80-90-100/112	●	35
56	360	24.98	1.2	30/35/40			602C	100LA4	71 <sup>B</sup> -80-90-100/112	80-90-100/112	●	37
57	354	24.61	1.4	30/35/40		602A		100LA4	71 <sup>B</sup> -80-90-100/112	80-90-100/112	●	35
57	354	24.61	0.9	28/30/35		502A		100LA4	71 <sup>B</sup> -80-90-100/112	80-90-100/112		33
70	290	20.10	1.0	28/30/35		452A		100LA4	71 <sup>B</sup> -80-90-100/112	80-90-100/112	●	31
70	290	20.10	1.1	28/30/35		502A		100LA4	71 <sup>B</sup> -80-90-100/112	80-90-100/112	●	33
70	290	20.10	1.7	30/35/40		602A		100LA4	71 <sup>B</sup> -80-90-100/112	80-90-100/112		35
70	290	20.10	1.7	30/35/40			602C	100LA4	71 <sup>B</sup> -80-90-100/112	80-90-100/112	●	37
84	239	16.62	1.3	28/30/35		452A		100LA4	71 <sup>B</sup> -80-90-100/112	80-90-100/112	●	31
84	239	16.62	1.5	28/30/35		502A		100LA4	71 <sup>B</sup> -80-90-100/112	80-90-100/112	●	33
84	239	16.62	2.1	30/35/40		602A		100LA4	71 <sup>B</sup> -80-90-100/112	80-90-100/112	●	35
84	239	16.62	2.1	30/35/40			602C	100LA4	71 <sup>B</sup> -80-90-100/112	80-90-100/112	●	37
99	205	14.21	1.2	28/30/35		502A		100LA4	71 <sup>B</sup> -80-90-100/112	80-90-100/112		33
99	205	14.21	1.3	28/30/35		452A		100LA4	71 <sup>B</sup> -80-90-100/112	80-90-100/112		31
99	205	14.21	2.0	30/35/40		602A		100LA4	71 <sup>B</sup> -80-90-100/112	80-90-100/112		35
99	205	14.21	2.1	30/35/40			602C	100LA4	71 <sup>B</sup> -80-90-100/112	80-90-100/112		37
106	191	13.26	0.8	24/25		402A		100LA4	63 <sup>B</sup> -71-80-90	71 <sup>C</sup> -80 <sup>C</sup> -90-100/112		27
106	191	13.26	0.9	24/25			402C	100LA4	63 <sup>B</sup> -71-80-90	71 <sup>C</sup> -80 <sup>C</sup> -90-100/112		29
120	168	11.66	1.0	24/25		402A		100LA4	63 <sup>B</sup> -71-80-90	71 <sup>C</sup> -80 <sup>C</sup> -90-100/112		27
120	168	11.64	1.0	24/25			402C	100LA4	63 <sup>B</sup> -71-80-90	71 <sup>C</sup> -80 <sup>C</sup> -90-100/112		29
122	165	11.43	1.8	28/30/35		452A		100LA4	71 <sup>B</sup> -80-90-100/112	80-90-100/112-132		31
122	165	11.43	2.0	28/30/35		502A		100LA4	71 <sup>B</sup> -80-90-100/112	80-90-100/112		33
122	165	11.43	2.4	30/35/40		602A		100LA4	71 <sup>B</sup> -80-90-100/112	80-90-100/112-132		35
122	165	11.43	2.4	30/35/40			602C	100LA4	71 <sup>B</sup> -80-90-100/112	80-90-100/112-132		37
139	145	10.06	1.0	24/25		402A		100LA4	63 <sup>B</sup> -71-80-90	71 <sup>C</sup> -80 <sup>C</sup> -90-100/112	●	27
139	145	10.04	1.0	24/25			402C	100LA4	63 <sup>B</sup> -71-80-90	71 <sup>C</sup> -80 <sup>C</sup> -90-100/112	●	29
148	136	9.45	2.2	28/30/35		452A		100LA4	71 <sup>B</sup> -80-90-100/112	80-90-100/112-132	●	31
148	136	9.45	2.6	28/30/35		502A		100LA4	71 <sup>B</sup> -80-90-100/112	80-90-100/112-132	●	33
148	136	9.45	2.9	30/35/40		602A		100LA4	71 <sup>B</sup> -80-90-100/112	80-90-100/112-132	●	35
148	136	9.45	2.9	30/35/40			602C	100LA4	71 <sup>B</sup> -80-90-100/112	80-90-100/112-132	●	37
156	129	8.96	1.2	24/25			402C	100LA4	63 <sup>B</sup> -71-80-90	71 <sup>C</sup> -80 <sup>C</sup> -90-100/112		29
176	115	7.96	2.6	28/30/35		452A		100LA4	71 <sup>B</sup> -80-90-100/112	80-90-100/112-132		31
176	115	7.96	2.9	28/30/35		502A		100LA4	71 <sup>B</sup> -80-90-100/112	80-90-100/112-132		33
177	114	7.89	1.1	24/25		402A		100LA4	63 <sup>B</sup> -71-80-90	71 <sup>C</sup> -80 <sup>C</sup> -90-100/112		27

B

Монтируется с проставкой  
Coupling by means of reduction bushing



C

Положение отверстий моторного  
фланца редуктора  
Motor flange/terminal box position







**P<sub>1M</sub> = 2.2 kW**

1400 min<sup>-1</sup> (100LA4)

n <sub>2</sub> [min <sup>-1</sup> ]	M <sub>2</sub> [Nm]	i	fs						1400 min <sup>-1</sup> (100LA4)				Размеры на странице
									B5	B14			
184	112	7.63	1.0	24/28	511			100LA4	71 <sup>B</sup> -80-90-100/112	80-90-100/112			21
191	106	7.33	1.1	24/25		402A		100LA4	63 <sup>B</sup> -71-80-90	71 <sup>C</sup> -80 <sup>C</sup> -90-100/112			27
191	106	7.33	1.4	24/25			402C	100LA4	63 <sup>B</sup> -71-80-90	71 <sup>C</sup> -80 <sup>C</sup> -90-100/112			29
206	98	6.81	2.8	28/30/35		452A		100LA4	71 <sup>B</sup> -80-90-100/112	80-90-100/112-132			31
220	92	6.36	1.0	24/25		402A		100LA4	63 <sup>B</sup> -71-80-90	71 <sup>C</sup> -80 <sup>C</sup> -90-100/112			27
231	87	6.07	2.9	28/30/35		502A		100LA4	71 <sup>B</sup> -80-90-100/112	80-90-100/112-132			33
231	87	6.07	2.9	28/30/35		452A		100LA4	71 <sup>B</sup> -80-90-100/112	80-90-100/112-132			31
252	80	5.55	1.3	24/25		402A		100LA4	63 <sup>B</sup> -71-80-90	71 <sup>C</sup> -80 <sup>C</sup> -90-100/112	●		27
252	80	5.55	1.5	24/25			402C	100LA4	63 <sup>B</sup> -71-80-90	71 <sup>C</sup> -80 <sup>C</sup> -90-100/112	●		29
266	78	5.27	1.7	24/28	511			100LA4	71 <sup>B</sup> -80-90-100/112	80-90-100/112			21
279	72	5.01	2.8	28/30/35		452A		100LA4	71 <sup>B</sup> -80-90-100/112	80-90-100/112-132	●		31
279	72	5.01	2.8	28/30/35		502A		100LA4	71 <sup>B</sup> -80-90-100/112	80-90-100/112-132	●		33
320	63	4.37	1.4	24/25		402A		100LA4	63 <sup>B</sup> -71-80-90	71 <sup>C</sup> -80 <sup>C</sup> -90-100/112			27
325	63	4.31	2.1	24/28	511			100LA4	71 <sup>B</sup> -80-90-100/112	80-90-100/112			21
331	61	4.23	2.8	28/30/35		452A		100LA4	71 <sup>B</sup> -80-90-100/112	80-90-100/112-132			31
331	61	4.23	2.8	28/30/35		502A		100LA4	71 <sup>B</sup> -80-90-100/112	80-90-100/112-132			33
388	52	3.61	2.9	28/30/35		452A		100LA4	71 <sup>B</sup> -80-90-100/112	80-90-100/112-132			31
388	52	3.61	2.9	28/30/35		502A		100LA4	71 <sup>B</sup> -80-90-100/112	80-90-100/112-132			33
398	51	3.52	1.6	24/25		402A		100LA4	63 <sup>B</sup> -71-80-90	71 <sup>C</sup> -80 <sup>C</sup> -90-100/112			27
423	49	3.31	2.5	24/28	511			100LA4	71 <sup>B</sup> -80-90-100/112	80-90-100/112			21
426	48	3.29	1.0	19/24	411			100LA4	63 <sup>B</sup> -71 <sup>B</sup> -80-90	71 <sup>B</sup> -80 <sup>C</sup> -90			20
493	42	2.84	1.0	19/24	411			100LA4	63 <sup>B</sup> -71 <sup>B</sup> -80-90	71 <sup>B</sup> -80 <sup>C</sup> -90			20
571	36	2.45	3.4	24/28	511			100LA4	71 <sup>B</sup> -80-90-100/112	80-90-100/112			21
892	23	1.57	1.8	19/24	411			100LA4	63 <sup>B</sup> -71 <sup>B</sup> -80-90	71 <sup>B</sup> -80 <sup>C</sup> -90			20

**P<sub>1M</sub> = 3.0 kW**

1400 min<sup>-1</sup> (100B4)

56	491	24.98	0.8	30/35/40		602A		100B4	71 <sup>B</sup> -80-90-100/112	80-90-100/112	●		35
56	491	24.98	0.9	30/35/40			602C	100B4	71 <sup>B</sup> -80-90-100/112	80-90-100/112	●		37
57	483	24.61	1.0	30/35/40		602A		100B4	71 <sup>B</sup> -80-90-100/112	80-90-100/112	●		35
70	395	20.10	0.8	28/30/35		502A		100B4	71 <sup>B</sup> -80-90-100/112	80-90-100/112	●		33
70	395	20.10	1.3	30/35/40		602A		100B4	71 <sup>B</sup> -80-90-100/112	80-90-100/112			35
70	395	20.10	1.3	30/35/40			602C	100B4	71 <sup>B</sup> -80-90-100/112	80-90-100/112	●		37
84	327	16.62	0.9	28/30/35		452A		100B4	71 <sup>B</sup> -80-90-100/112	80-90-100/112	●		31
84	327	16.62	1.1	28/30/35		502A		100B4	71 <sup>B</sup> -80-90-100/112	80-90-100/112	●		33
84	327	16.62	1.5	30/35/40		602A		100B4	71 <sup>B</sup> -80-90-100/112	80-90-100/112	●		35
84	327	16.62	1.5	30/35/40			602C	100B4	71 <sup>B</sup> -80-90-100/112	80-90-100/112	●		37
99	279	14.21	0.9	28/30/35		502A		100B4	71 <sup>B</sup> -80-90-100/112	80-90-100/112			33
99	279	14.21	0.9	28/30/35		452A		100B4	71 <sup>B</sup> -80-90-100/112	80-90-100/112			31
99	279	14.21	1.4	30/35/40		602A		100B4	71 <sup>B</sup> -80-90-100/112	80-90-100/112			35
99	279	14.21	1.6	30/35/40			602C	100B4	71 <sup>B</sup> -80-90-100/112	80-90-100/112	●		37
122	225	11.43	1.3	28/30/35		452A		100B4	71 <sup>B</sup> -80-90-100/112	80-90-100/112-132			31
122	225	11.43	1.5	28/30/35		502A		100B4	71 <sup>B</sup> -80-90-100/112	80-90-100/112			33
122	225	11.43	1.8	30/35/40		602A		100B4	71 <sup>B</sup> -80-90-100/112	80-90-100/112-132			35
122	225	11.43	1.8	30/35/40			602C	100B4	71 <sup>B</sup> -80-90-100/112	80-90-100/112-132			37
148	186	9.45	1.6	28/30/35		452A		100B4	71 <sup>B</sup> -80-90-100/112	80-90-100/112-132	●		31
148	186	9.45	1.9	28/30/35		502A		100B4	71 <sup>B</sup> -80-90-100/112	80-90-100/112-132	●		33
148	186	9.45	2.2	30/35/40		602A		100B4	71 <sup>B</sup> -80-90-100/112	80-90-100/112-132	●		35
148	186	9.45	2.2	30/35/40			602C	100B4	71 <sup>B</sup> -80-90-100/112	80-90-100/112-132	●		37
156	176	8.96	0.9	24/25			402C	100B4	63 <sup>B</sup> -71-80-90	71 <sup>C</sup> -80 <sup>C</sup> -90-100/112			29
176	156	7.96	1.9	28/30/35		452A		100B4	71 <sup>B</sup> -80-90-100/112	80-90-100/112-132			31
176	156	7.96	2.1	28/30/35		502A		100B4	71 <sup>B</sup> -80-90-100/112	80-90-100/112-132			33
176	156	7.96	2.4	30/35/40		602A		100B4	71 <sup>B</sup> -80-90-100/112	80-90-100/112-132			35
176	156	7.96	2.4	30/35/40			602C	100B4	71 <sup>B</sup> -80-90-100/112	80-90-100/112-132			37

B

Монтируется с проставкой  
Coupling by means of reduction bushing



C

Положение отверстий моторного  
фланца редуктора  
Motor flange/terminal box position





**ВЫБОР МОТОР-РЕДУКТОРОВ / GEARMOTORS SELECTION / WAHL DES GETRIEBEMOTORS  
SELECTION DES MOTO-REDUCTEURS / SELECCIYN MOTO-REDUCTORES**

**P<sub>1M</sub> = 3 kW**

**1400 min<sup>-1</sup> (100B4)**

n <sub>2</sub> [min <sup>-1</sup> ]	M <sub>2</sub> [Nm]	i	fs										
									B5	B14			
191	144	7.33	0.8	24/25		402A	100B4	63 <sup>B</sup> -71-80-90	71 <sup>C</sup> -80 <sup>C</sup> -90-100/112			27	
191	144	7.33	1.0	24/25			402C	100B4	63 <sup>B</sup> -71-80-90	71 <sup>C</sup> -80 <sup>C</sup> -90-100/112			29
206	134	6.81	2.1	28/30/35		452A	100B4	71 <sup>B</sup> -80-90-100/112	80-90-100/112-132			31	
206	134	6.81	2.2	28/30/35		502A	100B4	71 <sup>B</sup> -80-90-100/112	80-90-100/112-132			33	
206	134	6.81	2.5	30/35/40		602A	100B4	71 <sup>B</sup> -80-90-100/112	80-90-100/112-132			35	
206	134	6.81	2.5	30/35/40			602C	100B4	71 <sup>B</sup> -80-90-100/112	80-90-100/112-132			37
231	119	6.07	2.1	28/30/35		502A	100B4	71 <sup>B</sup> -80-90-100/112	80-90-100/112-132			33	
231	119	6.07	2.3	30/35/40		602A	100B4	71 <sup>B</sup> -80-90-100/112	80-90-100/112-132			35	
231	119	6.07	2.3	30/35/40			602C	100B4	71 <sup>B</sup> -80-90-100/112	80-90-100/112-132			37
231	119	6.07	2.1	28/30/35		452A	100B4	71 <sup>B</sup> -80-90-100/112	80-90-100/112-132			31	
252	109	5.55	0.9	24/25		402A	100B4	63 <sup>B</sup> -71-80-90	71 <sup>C</sup> -80 <sup>C</sup> -90-100/112	●		27	
252	109	5.55	1.1	24/25			402C	100B4	63 <sup>B</sup> -71-80-90	71 <sup>C</sup> -80 <sup>C</sup> -90-100/112	●		29
266	106	5.27	1.3	24/28	511		100B4	71 <sup>B</sup> -80-90-100/112	80-90-100/112		●	21	
279	98	5.01	2.0	28/30/35		452A	100B4	71 <sup>B</sup> -80-90-100/112	80-90-100/112-132		●	31	
279	98	5.01	2.0	28/30/35		502A	100B4	71 <sup>B</sup> -80-90-100/112	80-90-100/112-132		●	33	
279	98	5.01	2.4	30/35/40		602A	100B4	71 <sup>B</sup> -80-90-100/112	80-90-100/112-132		●	35	
279	98	5.01	2.4	30/35/40			602C	100B4	71 <sup>B</sup> -80-90-100/112	80-90-100/112-132	●		37
320	86	4.37	1.0	24/25		402A	100B4	63 <sup>B</sup> -71-80-90	71 <sup>C</sup> -80 <sup>C</sup> -90-100/112			27	
325	86	4.31	1.5	24/28	511		100B4	71 <sup>B</sup> -80-90-100/112	80-90-100/112			21	
331	83	4.23	2.0	28/30/35		452A	100B4	71 <sup>B</sup> -80-90-100/112	80-90-100/112-132			31	
331	83	4.23	2.0	28/30/35		502A	100B4	71 <sup>B</sup> -80-90-100/112	80-90-100/112-132			33	
331	83	4.23	2.4	30/35/40		602A	100B4	71 <sup>B</sup> -80-90-100/112	80-90-100/112-132			35	
331	83	4.23	2.4	30/35/40			602C	100B4	71 <sup>B</sup> -80-90-100/112	80-90-100/112-132			37
388	71	3.61	2.1	28/30/35		452A	100B4	71 <sup>B</sup> -80-90-100/112	80-90-100/112-132			31	
388	71	3.61	2.1	28/30/35		502A	100B4	71 <sup>B</sup> -80-90-100/112	80-90-100/112-132			33	
388	71	3.61	2.3	30/35/40		602A	100B4	71 <sup>B</sup> -80-90-100/112	80-90-100/112-132			35	
388	71	3.61	2.3	30/35/40			602C	100B4	71 <sup>B</sup> -80-90-100/112	80-90-100/112-132			37
398	69	3.52	1.2	24/25		402A	100B4	63 <sup>B</sup> -71-80-90	71 <sup>C</sup> -80 <sup>C</sup> -90-100/112			27	
423	66	3.31	1.8	24/28	511		100B4	71 <sup>B</sup> -80-90-100/112	80-90-100/112			21	
571	49	2.45	2.5	24/28	511		100B4	71 <sup>B</sup> -80-90-100/112	80-90-100/112			21	
1077	26	1.30	2.6	24/28	511		100B4	71 <sup>B</sup> -80-90-100/112	80-90-100/112			21	

**P<sub>1M</sub> = 4.0 kW**

**1400 min<sup>-1</sup> (112M4)**

70	527	20.10	0.9	30/35/40		602A	112M4	71 <sup>B</sup> -80-90-100/112	80-90-100/112			35	
70	527	20.10	0.9	30/35/40			602C	112M4	71 <sup>B</sup> -80-90-100/112	80-90-100/112	●		37
84	435	16.62	0.8	28/30/35		502A	112M4	71 <sup>B</sup> -80-90-100/112	80-90-100/112		●	33	
84	435	16.62	1.2	30/35/40		602A	112M4	71 <sup>B</sup> -80-90-100/112	80-90-100/112		●	35	
84	435	16.62	1.2	30/35/40			602C	112M4	71 <sup>B</sup> -80-90-100/112	80-90-100/112	●		37
99	372	14.21	1.1	30/35/40		602A	112M4	71 <sup>B</sup> -80-90-100/112	80-90-100/112			35	
99	372	14.21	1.2	30/35/40			602C	112M4	71 <sup>B</sup> -80-90-100/112	80-90-100/112			37
122	299	11.43	1.0	28/30/35		452A	112M4	71 <sup>B</sup> -80-90-100/112	80-90-100/112-132			31	
122	299	11.43	1.1	28/30/35		502A	112M4	71 <sup>B</sup> -80-90-100/112	80-90-100/112			33	
122	299	11.43	1.3	30/35/40		602A	112M4	71 <sup>B</sup> -80-90-100/112	80-90-100/112-132			35	
122	299	11.43	1.3	30/35/40			602C	112M4	71 <sup>B</sup> -80-90-100/112	80-90-100/112-132			37
148	248	9.45	1.2	28/30/35		452A	112M4	71 <sup>B</sup> -80-90-100/112	80-90-100/112-132	●		31	
148	248	9.45	1.4	28/30/35		502A	112M4	71 <sup>B</sup> -80-90-100/112	80-90-100/112-132		●	33	
148	248	9.45	1.6	30/35/40		602A	112M4	71 <sup>B</sup> -80-90-100/112	80-90-100/112-132		●	35	
148	248	9.45	1.6	30/35/40			602C	112M4	71 <sup>B</sup> -80-90-100/112	80-90-100/112-132	●		37
176	209	7.96	1.4	28/30/35		452A	112M4	71 <sup>B</sup> -80-90-100/112	80-90-100/112-132			31	
176	209	7.96	1.6	28/30/35		502A	112M4	71 <sup>B</sup> -80-90-100/112	80-90-100/112-132			33	
176	209	7.96	1.8	30/35/40		602A	112M4	71 <sup>B</sup> -80-90-100/112	80-90-100/112-132			35	
176	209	7.96	1.8	30/35/40			602C	112M4	71 <sup>B</sup> -80-90-100/112	80-90-100/112-132			37
206	178	6.81	1.6	28/30/35		452A	112M4	71 <sup>B</sup> -80-90-100/112	80-90-100/112-132			31	

**B**

Монтируется с проставкой  
Coupling by means of reduction bushing



**C**

Положение отверстий моторного  
фланца редуктора  
Motor flange/terminal box position







**P<sub>1M</sub> = 4 kW**

1400 min<sup>-1</sup> (112M4)

n <sub>2</sub> [min <sup>-1</sup> ]	M <sub>2</sub> [Nm]	i	fs						1400 min <sup>-1</sup> (112M4)			
									B5	B14		
206	178	6.81	1.7	28/30/35		502A		112M4	71 <sup>B</sup> -80-90-100/112	80-90-100/112-132		33
206	178	6.81	1.9	30/35/40		602A		112M4	71 <sup>B</sup> -80-90-100/112	80-90-100/112-132		35
206	178	6.81	1.9	30/35/40			602C	112M4	71 <sup>B</sup> -80-90-100/112	80-90-100/112-132		37
231	159	6.07	1.6	28/30/35		502A		112M4	71 <sup>B</sup> -80-90-100/112	80-90-100/112-132		33
231	159	6.07	1.7	30/35/40		602A		112M4	71 <sup>B</sup> -80-90-100/112	80-90-100/112-132		35
231	159	6.07	1.7	30/35/40			602C	112M4	71 <sup>B</sup> -80-90-100/112	80-90-100/112-132		37
231	159	6.07	1.6	28/30/35		452A		112M4	71 <sup>B</sup> -80-90-100/112	80-90-100/112-132		31
252	145	5.55	0.8	24/25			402C	112M4	63 <sup>B</sup> -71-80-90	71 <sup>C</sup> -80 <sup>C</sup> -90-100/112	●	29
266	141	5.27	0.9	24/28	511			112M4	71 <sup>B</sup> -80-90-100/112	80-90-100/112		21
279	131	5.01	1.5	28/30/35		452A		112M4	71 <sup>B</sup> -80-90-100/112	80-90-100/112-132	●	31
279	131	5.01	1.5	28/30/35		502A		112M4	71 <sup>B</sup> -80-90-100/112	80-90-100/112-132	●	33
279	131	5.01	1.8	30/35/40		602A		112M4	71 <sup>B</sup> -80-90-100/112	80-90-100/112-132	●	35
279	131	5.01	1.8	30/35/40			602C	112M4	71 <sup>B</sup> -80-90-100/112	80-90-100/112-132	●	37
325	115	4.31	1.2	24/28	511			112M4	71 <sup>B</sup> -80-90-100/112	80-90-100/112		21
331	111	4.23	1.5	28/30/35		452A		112M4	71 <sup>B</sup> -80-90-100/112	80-90-100/112-132		31
331	111	4.23	1.5	28/30/35		502A		112M4	71 <sup>B</sup> -80-90-100/112	80-90-100/112-132		33
331	111	4.23	1.8	30/35/40		602A		112M4	71 <sup>B</sup> -80-90-100/112	80-90-100/112-132		35
331	111	4.23	1.8	30/35/40			602C	112M4	71 <sup>B</sup> -80-90-100/112	80-90-100/112-132		37
388	95	3.61	1.6	28/30/35		452A		112M4	71 <sup>B</sup> -80-90-100/112	80-90-100/112-132		31
388	95	3.61	1.6	28/30/35		502A		112M4	71 <sup>B</sup> -80-90-100/112	80-90-100/112-132		33
388	95	3.61	1.7	30/35/40		602A		112M4	71 <sup>B</sup> -80-90-100/112	80-90-100/112-132		35
388	95	3.61	1.7	30/35/40			602C	112M4	71 <sup>B</sup> -80-90-100/112	80-90-100/112-132		37
398	92	3.52	0.9	24/25		402A		112M4	63 <sup>B</sup> -71-80-90	71 <sup>C</sup> -80 <sup>C</sup> -90-100/112		27
423	89	3.31	1.4	24/28	511			112M4	71 <sup>B</sup> -80-90-100/112	80-90-100/112		21
571	66	2.45	1.9	24/28	511			112M4	71 <sup>B</sup> -80-90-100/112	80-90-100/112		21
1077	35	1.30	1.9	24/28	511			112M4	71 <sup>B</sup> -80-90-100/112	80-90-100/112		21

**P<sub>1M</sub> = 5.5 kW**

1400 min<sup>-1</sup> (132S4)

122	412	11.43	1.0	30/35/40		602A		132S4	71 <sup>B</sup> -80-90-100/112	80-90-100/112-132		35
122	412	11.43	1.0	30/35/40			602C	132S4	71 <sup>B</sup> -80-90-100/112	80-90-100/112-132		37
148	340	9.45	0.9	28/30/35		452A		132S4	71 <sup>B</sup> -80-90-100/112	80-90-100/112-132	●	31
148	340	9.45	1.0	28/30/35		502A		132S4	71 <sup>B</sup> -80-90-100/112	80-90-100/112-132	●	33
148	340	9.45	1.2	30/35/40		602A		132S4	71 <sup>B</sup> -80-90-100/112	80-90-100/112-132	●	35
148	340	9.45	1.2	30/35/40			602C	132S4	71 <sup>B</sup> -80-90-100/112	80-90-100/112-132	●	37
176	287	7.96	1.0	28/30/35		452A		132S4	71 <sup>B</sup> -80-90-100/112	80-90-100/112-132		31
176	287	7.96	1.2	28/30/35		502A		132S4	71 <sup>B</sup> -80-90-100/112	80-90-100/112-132		33
176	287	7.96	1.3	30/35/40		602A		132S4	71 <sup>B</sup> -80-90-100/112	80-90-100/112-132		35
176	287	7.96	1.3	30/35/40			602C	132S4	71 <sup>B</sup> -80-90-100/112	80-90-100/112-132		37
206	245	6.81	1.1	28/30/35		452A		132S4	71 <sup>B</sup> -80-90-100/112	80-90-100/112-132		31
206	245	6.81	1.2	28/30/35		502A		132S4	71 <sup>B</sup> -80-90-100/112	80-90-100/112-132		33
206	245	6.81	1.4	30/35/40		602A		132S4	71 <sup>B</sup> -80-90-100/112	80-90-100/112-132		35
206	245	6.81	1.4	30/35/40			602C	132S4	71 <sup>B</sup> -80-90-100/112	80-90-100/112-132		37
231	219	6.07	1.1	28/30/35		502A		132S4	71 <sup>B</sup> -80-90-100/112	80-90-100/112-132		33
231	219	6.07	1.2	30/35/40		602A		132S4	71 <sup>B</sup> -80-90-100/112	80-90-100/112-132		35
231	219	6.07	1.2	30/35/40			602C	132S4	71 <sup>B</sup> -80-90-100/112	80-90-100/112-132		37
231	219	6.07	1.1	28/30/35		452A		132S4	71 <sup>B</sup> -80-90-100/112	80-90-100/112-132		31
279	180	5.01	1.1	28/30/35		452A		132S4	71 <sup>B</sup> -80-90-100/112	80-90-100/112-132	●	31
279	180	5.01	1.1	28/30/35		502A		132S4	71 <sup>B</sup> -80-90-100/112	80-90-100/112-132	●	33
279	180	5.01	1.3	30/35/40		602A		132S4	71 <sup>B</sup> -80-90-100/112	80-90-100/112-132	●	35
279	180	5.01	1.3	30/35/40			602C	132S4	71 <sup>B</sup> -80-90-100/112	80-90-100/112-132	●	37
331	152	4.23	1.1	28/30/35		452A		132S4	71 <sup>B</sup> -80-90-100/112	80-90-100/112-132		31
331	152	4.23	1.1	28/30/35		502A		132S4	71 <sup>B</sup> -80-90-100/112	80-90-100/112-132		33
331	152	4.23	1.3	30/35/40		602A		132S4	71 <sup>B</sup> -80-90-100/112	80-90-100/112-132		35

B

Монтируется с проставкой  
Coupling by means of reduction bushing



C

Положение отверстий моторного  
фланца редуктора  
Motor flange/terminal box position





ВЫБОР МОТОР-РЕДУКТОРОВ / GEARMOTORS SELECTION / WAHL DES GETRIEBEMOTORS  
SELECTION DES MOTO-REDUCTEURS / SELECCIYN MOTO-REDUCTORES

**P<sub>1M</sub> = 5.5 kW**

2800 min<sup>-1</sup> (132SA2) - 1400 min<sup>-1</sup> (132S4)

n <sub>2</sub> [min <sup>-1</sup> ]	M <sub>2</sub> [Nm]	i	fs										
									B5	B14			
331	152	4.23	1.3	30/35/40				602C	132S4	71 <sup>B</sup> -80-90-100/112	80-90-100/112-132		37
388	130	3.61	1.2	28/30/35			452A		132S4	71 <sup>B</sup> -80-90-100/112	80-90-100/112-132		31
388	130	3.61	1.2	28/30/35			502A		132S4	71 <sup>B</sup> -80-90-100/112	80-90-100/112-132		33
388	130	3.61	1.3	30/35/40			602A		132S4	71 <sup>B</sup> -80-90-100/112	80-90-100/112-132		35
388	130	3.61	1.3	30/35/40				602C	132S4	71 <sup>B</sup> -80-90-100/112	80-90-100/112-132		37
411	123	6.81	2.3	28/30/35			452A		132SA2	71 <sup>B</sup> -80-90-100/112	80-90-100/112-132		31
411	123	6.81	2.4	28/30/35			502A		132SA2	71 <sup>B</sup> -80-90-100/112	80-90-100/112-132		33
462	109	6.07	2.3	28/30/35			452A		132SA2	71 <sup>B</sup> -80-90-100/112	80-90-100/112-132		31
559	90	5.01	2.2	28/30/35			502A		132SA2	71 <sup>B</sup> -80-90-100/112	80-90-100/112-132	●	33
559	90	5.01	2.2	28/30/35			452A		132SA2	71 <sup>B</sup> -80-90-100/112	80-90-100/112-132	●	31
662	76	4.23	2.2	28/30/35			502A		132SA2	71 <sup>B</sup> -80-90-100/112	80-90-100/112-132		33
662	76	4.23	2.2	28/30/35			452A		132SA2	71 <sup>B</sup> -80-90-100/112	80-90-100/112-132		31
776	65	3.61	2.3	28/30/35			502A		132SA2	71 <sup>B</sup> -80-90-100/112	80-90-100/112-132		33
776	65	3.61	2.3	28/30/35			452A		132SA2	71 <sup>B</sup> -80-90-100/112	80-90-100/112-132		31

**P<sub>1M</sub> = 7.5 kW**

n<sub>1</sub> = 2800 min<sup>-1</sup> (132SB2) - 1400 min<sup>-1</sup> (132MA4)

148	464	9.45	0.9	30/35/40			602A		132MA4	71 <sup>B</sup> -80-90-100/112	80-90-100/112-132	●	35
148	464	9.45	0.9	30/35/40				602C	132MA4	71 <sup>B</sup> -80-90-100/112	80-90-100/112-132	●	37
176	391	7.96	0.8	28/30/35			502A		132MA4	71 <sup>B</sup> -80-90-100/112	80-90-100/112-132		33
176	391	7.96	0.9	30/35/40			602A		132MA4	71 <sup>B</sup> -80-90-100/112	80-90-100/112-132		35
176	391	7.96	0.9	30/35/40				602C	132MA4	71 <sup>B</sup> -80-90-100/112	80-90-100/112-132		37
206	334	6.81	0.8	28/30/35			452A		132MA4	71 <sup>B</sup> -80-90-100/112	80-90-100/112-132		31
206	334	6.81	0.9	28/30/35			502A		132MA4	71 <sup>B</sup> -80-90-100/112	80-90-100/112-132		33
206	334	6.81	1.0	30/35/40			602A		132MA4	71 <sup>B</sup> -80-90-100/112	80-90-100/112-132		35
206	334	6.81	1.0	30/35/40				602C	132MA4	71 <sup>B</sup> -80-90-100/112	80-90-100/112-132		37
231	298	6.07	0.8	28/30/35			502A		132MA4	71 <sup>B</sup> -80-90-100/112	80-90-100/112-132		33
231	298	6.07	0.9	30/35/40			602A		132MA4	71 <sup>B</sup> -80-90-100/112	80-90-100/112-132		35
231	298	6.07	0.9	30/35/40				602C	132MA4	71 <sup>B</sup> -80-90-100/112	80-90-100/112-132		37
231	298	6.07	0.8	28/30/35			452A		132MA4	71 <sup>B</sup> -80-90-100/112	80-90-100/112-132		31
279	246	5.01	0.8	28/30/35			452A		132MA4	71 <sup>B</sup> -80-90-100/112	80-90-100/112-132	●	31
279	246	5.01	0.8	28/30/35			502A		132MA4	71 <sup>B</sup> -80-90-100/112	80-90-100/112-132	●	33
279	246	5.01	1.0	30/35/40			602A		132MA4	71 <sup>B</sup> -80-90-100/112	80-90-100/112-132	●	35
279	246	5.01	1.0	30/35/40				602C	132MA4	71 <sup>B</sup> -80-90-100/112	80-90-100/112-132	●	37
331	208	4.23	0.8	28/30/35			452A		132MA4	71 <sup>B</sup> -80-90-100/112	80-90-100/112-132		31
331	208	4.23	0.8	28/30/35			502A		132MA4	71 <sup>B</sup> -80-90-100/112	80-90-100/112-132		33
331	208	4.23	1.0	30/35/40			602A		132MA4	71 <sup>B</sup> -80-90-100/112	80-90-100/112-132		35
331	208	4.23	1.0	30/35/40				602C	132MA4	71 <sup>B</sup> -80-90-100/112	80-90-100/112-132		37
388	177	3.61	0.8	28/30/35			452A		132MA4	71 <sup>B</sup> -80-90-100/112	80-90-100/112-132		31
388	177	3.61	0.8	28/30/35			502A		132MA4	71 <sup>B</sup> -80-90-100/112	80-90-100/112-132		33
388	177	3.61	0.9	30/35/40			602A		132MA4	71 <sup>B</sup> -80-90-100/112	80-90-100/112-132		35
388	177	3.61	0.9	30/35/40				602C	132MA4	71 <sup>B</sup> -80-90-100/112	80-90-100/112-132		37
411	167	6.81	1.7	28/30/35			452A		132SB2	71 <sup>B</sup> -80-90-100/112	80-90-100/112-132		31
411	167	6.81	1.8	28/30/35			502A		132SB2	71 <sup>B</sup> -80-90-100/112	80-90-100/112-132		33
461	149	6.07	1.7	28/30/35			502A		132SB2	71 <sup>B</sup> -80-90-100/112	80-90-100/112-132		33
462	149	6.07	1.7	28/30/35			452A		132SB2	71 <sup>B</sup> -80-90-100/112	80-90-100/112-132		31
662	104	4.23	1.6	28/30/35			502A		132SB2	71 <sup>B</sup> -80-90-100/112	80-90-100/112-132		33
662	104	4.23	1.6	28/30/35			452A		132SB2	71 <sup>B</sup> -80-90-100/112	80-90-100/112-132		31
776	89	3.61	1.7	28/30/35			502A		132SB2	71 <sup>B</sup> -80-90-100/112	80-90-100/112-132		33
776	89	3.61	1.7	28/30/35			452A		132SB2	71 <sup>B</sup> -80-90-100/112	80-90-100/112-132		31

B

Монтируется с проставкой  
Coupling by means of reduction bushing



# По запросу / On request / Auf Anfrage / A la demande / A solicitud

Для применений требующих минеральной смазки, редукторы поставляются с пробками уровня масла и сливной пробкой (см. рисунок).

For applications requiring mineral oils, gearboxes can be delivered with oil plugs (level and leak) as represented in figure.

Getriebe mit mineralischem Öl müssen mit einer Entlüftungsschraube versehen werden. Die Position der Entlüftungs-, Ölstandskontroll- und Verschlusschraube sind in der folgenden Aufstellung ersichtlich.

Dans le cas dans lequel soit demandé un réducteur lubrifié avec huile minérale nous pouvons à la demande fournir la caisse complète de quatre bouchons (niveau et essoufflé) comme représentée en illustration.

En el caso en que sea requerido un reductor lubricado con aceite mineral podemos a solicitud proveer la caja completa de cuatro tapones (nivel y resollar) como representada en figura.

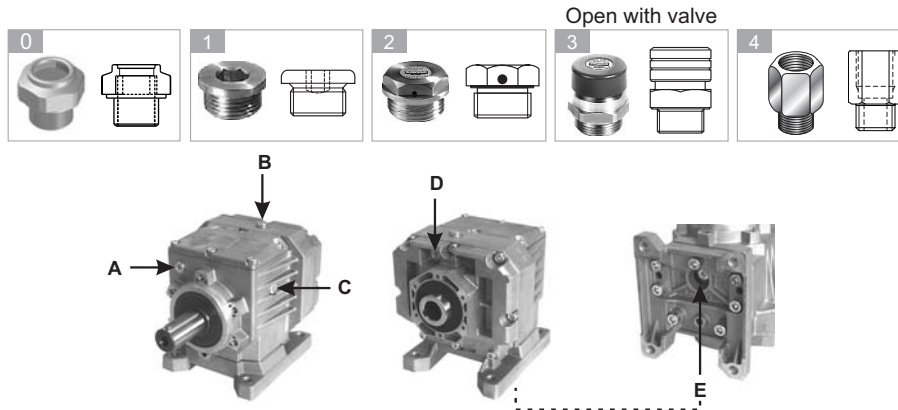

Позиции	B3 - B5	B6	B7	B8	V5 - V1	V6 - V3
<b>A</b>	1	2 (3)	1	1	1	2 (3)
<b>B</b>	2 (3)	0	0	1	0	1
<b>C</b>	0	1	4+1 (3)	5+0 (3)	1	0
<b>D</b>	1	1	1	1	4+2 (3)	1
<b>E</b>	1	1	1	2 (3)	1	1

# По запросу / On request / Auf Anfrage / A la demande / A solicitud

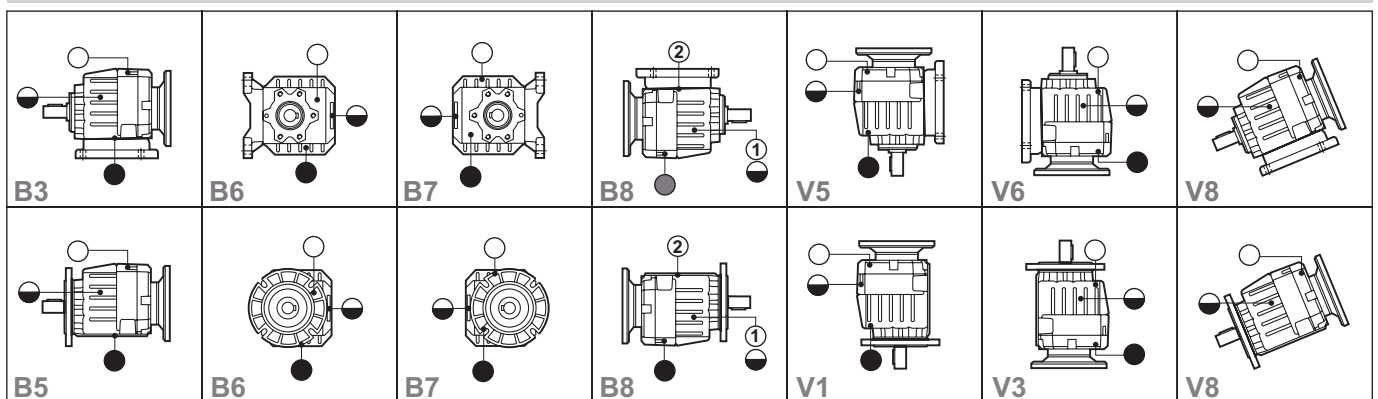

① 402A - 403A      ② 502A - 503A - 602A - 603A

Количество масла / Oil quantity / Ölmenge / Quantités d'huile / Cantidad de aceite [ l ]

<b>202A</b>	0.15	0.15	0.15	0.15	0.15	0.15	0.15
<b>302A</b>	0.15	0.15	0.15	0.15	0.15	0.15	0.15
<b>402A</b>	0.25	0.30	0.40	0.40	0.40	0.50	0.40
<b>403A</b>	0.30	0.35	0.45	0.45	0.45	0.55	0.45
<b>452A</b>	0.31	0.31	0.31	0.31	0.31	0.31	0.31
<b>502A</b>	0.45	0.55	1.00	1.10	1.10	1.15	1.10
<b>503A</b>	0.75	0.75	1.05	1.15	1.20	1.20	1.20
<b>602A</b>	0.55	0.85	1.10	1.20	1.20	1.25	1.20
<b>603A</b>	0.75	0.90	1.15	1.25	1.30	1.35	1.30



ДОПОЛНИТЕЛЬНЫЕ ПРИНАДЛЕЖНОСТИ / ACCESSORIES AND OPTIONALS /  
ACCESSOIRES ET VARIANTES / ACCESORIOS Y VARIANTES

AA

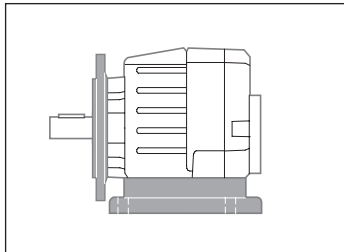

<b>202A</b>
<b>302A</b>
<b>402/3A</b>
<b>452A</b>
<b>502/3A</b>
<b>602/3A</b>

Монтируется с лапами и выходным фланцем  
Mounting with feet and output flange  
Montage mit Füssen und Ausgangsflansch  
Fixation avec des pieds et bride de sortie  
Tipo de montaje con pies y brida de salida

AB

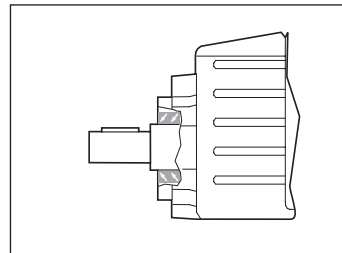

<b>402/3A</b>	25x47x7
<b>502/3A</b>	40x52x7
<b>602/3A</b>	50x62x7
<b>402/3C</b>	25x47x7
<b>602/3C</b>	50x68x8

Двойной маслостойкий уплотнитель выходного вала  
Output shaft double oilseal  
Abtriebswelle mit 2 Dichtungen  
Double joint a l'arbre de sortie  
Dos retenes en el eje de salida

AC

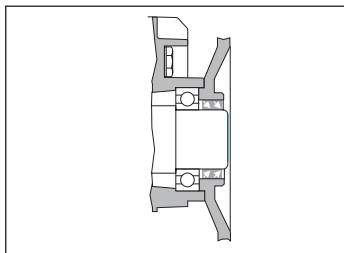

<b>311</b>	25x40x7
<b>411</b>	35x47x7
<b>202A</b>	28x40x7
<b>302A</b>	35x47x7
<b>402A</b>	35x47x7
<b>452A</b>	50x75x8
<b>503A</b>	35x47x7
<b>603A</b>	35x47x7
<b>402C</b>	35x47x7
<b>403C</b>	35x47x7
<b>603C</b>	35x47x7

Двойной уплотнитель входного вала  
Input double oilseal  
Doppelte Dichtung am Eintrieb  
Double joint a l'entrée  
Dos retenes en la entrada

AD

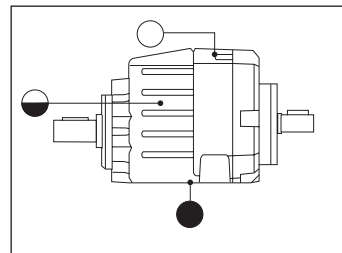

Залитый минеральной смазкой редуктор с сапуном  
Gearbox lubricated with mineral oil and breather plug  
Getriebe mit mineralöl und lberdruckventil schmiere  
Réducteur lubrifié avec huile minérale et bouchon d'évent  
Reductor lubricado con aceite mineral y tapón de respiradero

AE

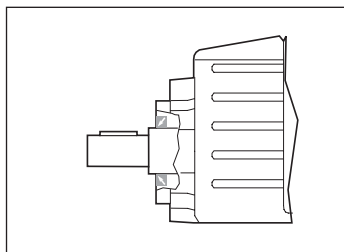

<b>311</b>	20x40x7
<b>411</b>	25x47x7
<b>511</b>	35x72x7
<b>202A</b>	30x47x7
<b>302A</b>	30x47x7
<b>402/3A</b>	30x52x7
<b>452A</b>	40x62x7
<b>502/3A</b>	35x72x7
<b>602/3A</b>	45x85x8
<b>402/3C</b>	30x52x7
<b>602/3C</b>	45x85x8

Витоновые уплотнители выходного вала  
Output shaft Viton oilseals  
Dichtung aus Viton auf der Abtriebswelle  
Bague d'étanchéité en Viton a l'arbre de sortie  
Reten de Viton en el eje de salida

AF

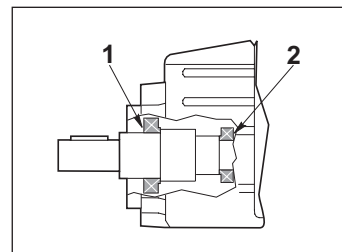

	<b>1</b>	<b>2</b>
<b>502A</b>	30207	30205
<b>503A</b>		
<b>602A</b>	30209	30206
<b>603A</b>		
<b>602C</b>	30209	30206
<b>603C</b>		

Конические роликовые подшипники выходного вала  
Taper roller bearings on the output shaft  
Schwere Kugellager an Antriebsseite  
Roulements coniques sur l'arbre de sortie  
Rodamientos cónicos en el árbol de salida

AG

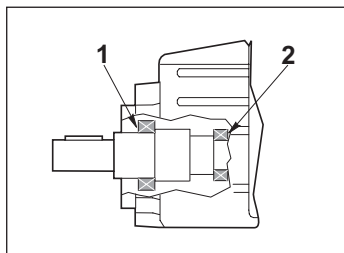

	<b>1</b>	<b>2</b>
<b>202A</b>	NJ204	NJ202
<b>302A</b>	NJ204	NJ202
<b>452A</b>	NJ206	NJ205

Цилиндрические роликовые подшипники выходного вала  
Cylindrical roller bearings on the output shaft  
Abtriebswelle mit Zylinderrollenlager  
Roulements a rouleaux cylindriques sur l'axe de sortie  
Rodamientos de rodillos cilíndricos en el eje de salida



AM

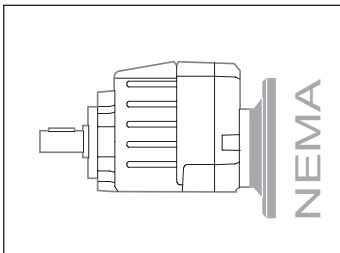

Входной фланец NEMA  
NEMA input flange  
NEMA-Eintriebsflansch  
Flasque d'entrée NEMA  
Brida de entrada NEMA

<b>202A</b>	56C - 0.625		
<b>302A</b>	56C - 0.625	143/5TC - 0.875	
<b>402A</b>	56C - 0.625	143/5TC - 0.875	
<b>403A</b>	56C - 0.625		
<b>452A</b>	56C - 0.625	143/5TC - 0.875	182/4TC - 1.125
<b>502A</b>	56C - 0.625	143/5TC - 0.875	182/4TC - 1.125
<b>503A</b>	56C - 0.625	143/5TC - 0.875	
<b>602A</b>	56C - 0.625	143/5TC - 0.875	182/4TC - 1.125
<b>603A</b>	56C - 0.625	143/5TC - 0.875	
<b>402C</b>	56C - 0.625	143/5TC - 0.875	
<b>403C</b>	56C - 0.625	143/5TC - 0.875	
<b>602C</b>	56C - 0.625	143/5TC - 0.875	182/4TC - 1.125
<b>603C</b>	56C - 0.625	143/5TC - 0.875	

AO

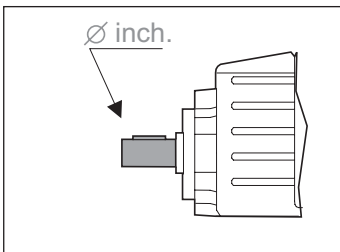

Диаметр выходного фланца в  
дюймах  
Output shaft in inches  
Ausgangswelle in Zoll  
Arbre de sortie en pouces

	ДЮЙМЫ	ММ
<b>202A</b>	0.625	15.875
	0.750	19.05
<b>302A</b>	0.750	19.05
<b>402/3A</b>	0.750	19.05
	1.000	25.40
<b>452A</b>	1.250	31.75
<b>502/3A</b>	1.250	31.75
<b>602/3A</b>	1.250	31.75
	1.375	34.93
<b>402/3C</b>	0.750	19.05
	1.000	25.40
<b>602/3C</b>	1.250	31.75
	1.375	34.93



✓ Please Check

RU

UK

**2p**  
n<sub>1</sub>=2800 min<sup>-1</sup>

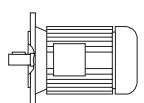

Двухполюсные двигатели могут эксплуатироваться только в кратковременном режиме. Отметьте данный пункт для определения оптимальных передаточных чисел.

2 poles can be used only for very intermittent applications only. Specify it in the order to select the most suitable ratios. To signal in phase of order if levels for noisiness are particular demands.

Отметьте данный пункт, если необходим малозумный режим работы двигателя.

**2RS** **2RS**

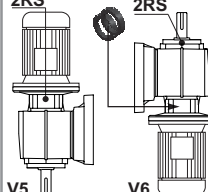

V5 V6

Не изменяйте монтажную позицию без разрешения производителя. Для изменения монтажной позиции может потребоваться определенный тип смазки. Если редукторы, установленные в монтажные позиции V5 или V6, эксплуатируются в непрерывном режиме, необходимо заменить верхний подшипник на самосмазывающийся подшипник. Для монтажной позиции типа V6 рекомендуется использовать двойной входной сальник.

Do not change mounting positions without contacting factory. Altering the mounting position may require special lubrication provisions which must be factory installed. When reducers are mounted in positions V5 or V6 and used in continuous duty applications, replace the upper bearing with a self lubricated style bearing, and we suggest double input seal for V6.

**FPM (fkm)**

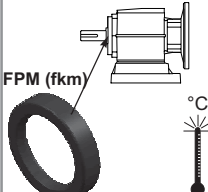

°C

При высоких рабочих температурах рекомендуется установить вайтоновый сальник на ступицу.

In case of temperatures high we advise to mount oil seal in VITON on the hub.

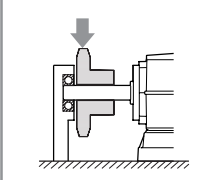

Для предотвращения преждевременного износа подшипника и поломки вала при большой радиальной нагрузке требуется дополнительная опора.

For very heavy radial load, additional output shaft support may be required to prevent premature bearing failure or shaft breakage from bending fatigue.

**TORQUE LIMITER**

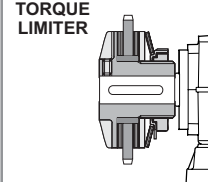

Если механизм эксплуатируется с большими ударными нагрузками и резкими остановками, рекомендуется использовать механические или электронные ограничители крутящего момента.

If the application subjects the reducer to shock loads and sudden stops it is advisable to use mechanical or electronic torque limiting devices.

**BRAKE**

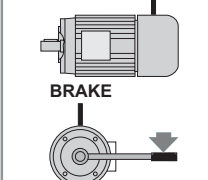

Редукторы не являются самоотключающимися устройствами. Для обеспечения данной функции необходимо использовать независимый блокиратор. Не следует использовать редукторы в качестве тормозного механизма. Нагрузки на редуктор не должны превышать указанных в данном каталоге.

Reducers are not to be considered fail safe or self-locking devices. If these features are required, a properly sized, independent holding device should be utilized. Reducers should not be used as a brake. Any brakes that are used in conjunction with a reducer must be sized or positioned in such a way so as to not subject the reducer to loads beyond the catalog rating.

**ATTENTION**  
Prior Authorization

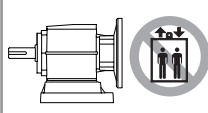

Для использования устройства в пассажирских лифтах или других устройствах, которые служат для перемещения людей, необходимо получить наше письменное разрешение.

Written authorization from Smart-Gears is required to operate or use reducers in man lift or people moving devices.





D

F

E

Ist für den Einsatz ein 2-poliger Motor vorgesehen, muss dies in der Bestellung spezifiziert werden.  
In der Auftragsphase muss angegeben werden, ob besondere Geräuschpegelwerte gefordert werden.

In der Bestellung muss darüber hinaus angegeben werden, ob die angeforderten Getriebe für senkrechte Einbautagen V5чV6 vorgesehen sind. Für diese Positionen muss ein abgeschirmtes Lager 2RS gemäß Abbildung vorgesehen werden. Für die Einbaulage V6 empfehlen wir, die Montage von 2 Dichtringen im Antrieb. V6 (Einbaulage, von der bei 2-poligen Motoren abgeraten wird).

Bei erhöhten Temperaturen empfehlen wir an der Nabe die Montage von Dichtringen aus VITON.

Bei Applikationen mit einer besonders hohen Radialkraft wird empfohlen, eine zusätzliche Abstützung an der Welle vorzusehen, um den vorzeitigen Verschleiß des Lagers oder den Bruch der Welle zu verhindern.

Sollten in der jeweiligen Applikation die Möglichkeit länger anliegender Überlastungen, von Stößen oder plötzlichen Blockierungen bestehen, sind mechanische oder elektronische Drehmomentbegrenzungsvorrichtungen zu installieren.

Darüber hinaus muss angegeben werden, ob der Einsatz einen selbstbremsenden Motor mit hoher Schaltfrequenz vorsieht. Bei den Installationen muss man sich darüber vergewissern, dass das von der Lastträgheit erzeugte Drehmoment die Grenzwerte des Getriebes nicht überschreitet. Überprüfen (mit einem Drehmomentenschlüssel), dass der Eichmoment der Bremse den vom Projekt vorgesehenen Daten entspricht.

Bei der Bestellung muss eine schriftliche Befugnis angefordert werden, die den Einsatz unserer Getriebe in Applikationen autorisiert, von dem bzw. bei dem Personen betroffen sind.

Préciser sur la commande si en cours d'utilisation il faut appliquer un moteur a 2 pôles. Préciser sur la commande si l'on exige des niveaux sonores particuliers.

Préciser si les réducteurs commandés doivent s'utiliser dans des positions de montage verticales V5чV6. Pour pareilles positions il faut prévoir un roulement blindé 2RS (voir figure). Pour un montage V6 on suggère l'utilisation de 2 bagues d'étanchéité en entrée. La V6 est une position déconseillée pour les moteurs a 2 pôles

En cas de températures élevées il est conseillé d'utiliser des bagues d'étanchéité en VITON sur le moyeu.

Dans des applications ayant une charge radiale élevée, il est conseillé de prévoir un support supplémentaire sur l'arbre pour empêcher l'usure prématurée du roulement ou la casse de l'arbre.

Si l'application prévoit des surcharges prolongées, chocs ou arrêts intempestifs, installer des systèmes mécaniques ou électroniques limitant le couple.

Signaler si l'utilisation est avec moteur auto-freiné avec un nombre élevé de manœuvres. Dans les installations s'assurer que le couple engendré par l'inertie de la charge en cours de freinage ne dépasse pas les limites du réducteur ; vérifier (avec une clé dynamométrique) que le couple de réglage du frein correspond aux données autorisées par le projet.

Pour pouvoir utiliser nos réducteurs dans des applications impliquant des personnes, il faut nous en demander l'autorisation par écrit lors de la commande.

Especificar en el pedido la utilización de motores de 2 Polos para lubricar el reductor con aceite sintético.  
Remarcar con el pedido si se requieren niveles reducidos de rumorosidad.

Especificar en el pedido si los reductores serán utilizados en posición de montaje vertical V5-V6. Para estas posiciones van montados rodamientos cerrados 2RS, como se indica en la figura.  
En el montaje V6 sugerimos el uso de dos retenes en la entrada. Desaconsejamos el montaje en posición V6 con motor de 2 Polos.

En caso de elevada temperatura ambiente aconsejamos montar retenes en viton en el eje de salida.

En aplicaciones con elevadas cargas radiales, aconsejamos el montaje de un soporte suplementario sobre el eje, para evitar el desgaste prematuro del rodamiento, o la rotura del eje.

Si en la aplicación se prevén sobrecargas prolongadas, golpes o bloqueos imprevistos, instalar sistemas mecánicos o electrónicos de limitadores de par.

Remarcar el uso de motor freno con alto número de maniobras.  
En las instalaciones con motores autofrenantes cerciorarse de que el par generado por la inercia de la carga en fase de frenado no supere los límites del reductor; comprobar (con llave dinamométrica) que el par de reglaje del freno corresponda con los datos reflejados por el proyecto.

Es obligatorio pedir nuestra autorización, para el uso de nuestros reductores en aplicaciones donde se transporten personas.



# КРАТКАЯ ИНСТРУКЦИЯ ПО УСТАНОВКЕ

✓ Please Check

RU

UK

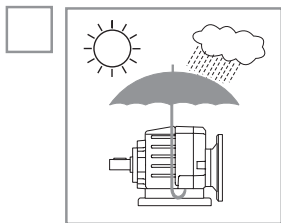

При установке устройства вне помещения обеспечьте защиту от воздействия окружающей среды.

When installed outdoors, make sure protection is provided from atmospheric elements.

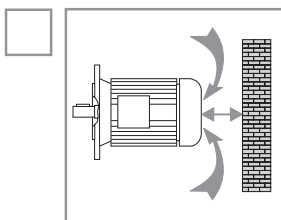

Для нормального охлаждения необходимо обеспечить достаточное пространство для воздухозаборника двигателя.

Make sure there is sufficient space between any obstructions and the motor's air intake area to provide adequate cooling for the motor.

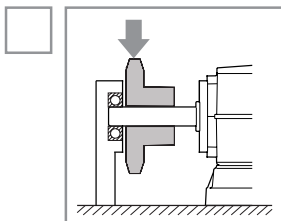

Для предотвращения преждевременного износа подшипника и поломки вала при большой радиальной нагрузке требуется дополнительная опора.

For very heavy radial load, additional output shaft support may be required to prevent premature bearing failure or shaft breakage from bending fatigue.

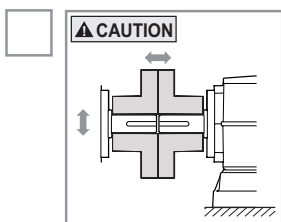

Система вращающихся деталей не должна подвергаться критическим скоростям, торсионной или другим типам вибрации, независимо от их источника. За оценку возможностей этой системы отвечает покупатель редуктора.

The system of connected rotating parts must be free from critical speed, torsional or other type vibration, no matter how induced. The responsibility for this system analysis lies with the purchaser of the speed reducer.

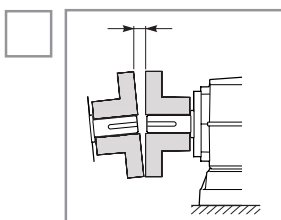

Убедитесь, что валы и муфты укреплены правильно. Проверьте плотность соединений, а затем зафиксируйте крепежные болты. Периодически проверяйте плотность крепления.

Check shaft and coupling alignment. Check proper coupling gap before to lock all foundation bolts that should be routinely checked.

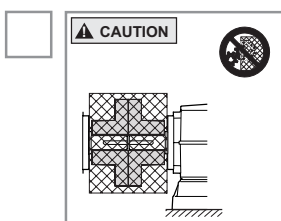

Пользователь обязан защитить вал и любые приводные механизмы, установленные на нем, с помощью предохранительного кожуха. Также пользователь должен следовать местным правилам по технике безопасности. Неправильная эксплуатация устройства может привести к серьезным травмам и/или повреждению оборудования.

For safety, Buyer or User should provide protective guards over all shaft extensions and any moving apparatus mounted thereon. The User is responsible for checking all applicable safety codes in his area and providing suitable guards. Failure to do so may result in bodily injury and/or damage to equipment.

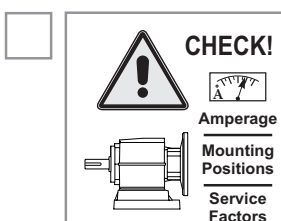

Осуществите пробный пуск устройства перед началом эксплуатации.

Test run the first unit to verify proper operation.



D

F

E

Bei im Freien installierten Getrieben sind angemessene Schutzvorrichtungen gegen Wettereinflüsse und direkte Bestrahlungen vorzusehen. Für die Installation in feuchten Umgebungen müssen an den bearbeiteten Flächen des Getriebes angemessene Schutzmaßnahmen getroffen werden.

Zwischen der Lüfterradabdeckung des Motors und der eventuellen Wand ausreichend Freiraum belassen, der einen Luftfluß für die Kühlung gewährleistet.

Bei Applikationen mit einer sehr hohen Radialkraft wird empfohlen, eine zusätzliche Abstützung an der Welle vorzusehen.

Die Verbindung der rotierenden Teile darf keinerlei durch die Geschwindigkeit erzeugte Verwindung oder Schwingung aufweisen.

Es wird empfohlen, vor der Inbetriebsetzung des Getriebes die Fluchtung der rotierenden Teile (Verbindungen, Wellen, usw.) zu kontrollieren und darüber hinaus regelmäßig die Befestigung der Verbindungsbolzen zu überprüfen.

Im Sinne der Sicherheit sollte der Käufer oder Benutzer über allen am Getriebe montierten Wellen und allen in Umdrehung gebrachten Geräte Schutzvorrichtungen vorsehen.

Es wird empfohlen, vor der Inbetriebsetzung einen Check-up mit Kontrolle der aufgenommenen Leistung vorzunehmen, um einen angemessenen Betrieb gewährleisten zu können.

Pour les réducteurs installés à l'extérieur, prévoir les protections qui se conviennent contre les éléments atmosphériques et le rayonnement solaire direct. Pour l'installation dans des endroits humides adopter des protections adéquates sur les surfaces usinées.

Entre le cache-pale de ventilation et toute paroi laisser un dégagement suffisant à garantir le passage de l'air de refroidissement.

Dans les applications impliquant une charge radiale très élevée, il est conseillé de prévoir un support supplémentaire sur l'arbre.

Le raccordement des pièces en rotation doit être libre de tout type de torsion ou vibration dues à la vitesse.

Il est conseillé de contrôler l'alignement des pièces en rotation (raccordements, arbres, etc.) avant la mise en service du réducteur et de vérifier périodiquement la fixation des boulons de raccordement.

À des fins de sécurité l'acheteur ou l'utilisateur devrait prévoir des protections pour tous les arbres et les appareils mis en rotation qui se trouvent montés sur les réducteurs.

Il est conseillé de réaliser un essai de vérification avant mise en service, pour s'assurer que le fonctionnement est approprié d'après le contrôle de la puissance absorbée.

Para reductores instalados al aire libre prever protecciones adecuadas contra los agentes atmosféricos y la irradiación directa. Para la instalación en ambientes húmedos, adoptense protectores adecuados en las superficies mecanizadas del reductor.

Dejar entre la tapa del ventilador del motor y la eventual pared, un espacio suficiente que garantice el paso del aire de refrigeración.

En aplicaciones con elevadas cargas radiales, aconsejamos el montaje de un soporte suplementario sobre el eje, para evitar el desgaste prematuro del rodamiento, o la rotura del eje.

La unión entre las partes en rotación, debe estar exenta de cualquier tipo de cargas o vibraciones debidas a la velocidad.

Aconsejamos controlar la alineación de los elementos en rotación, antes de la puesta en marcha del reductor, asimismo, recomendamos controlar periódicamente la fijación de los bulones de unión.

Por seguridad, el comprador o usuario, deben prever protecciones sobre todos los elementos en rotación montados sobre el reductor.

Aconsejamos efectuar un arranque en pruebas, antes de la puesta en funcionamiento, controlando la potencia absorbida y garantizando el uso correcto del reductor.



# КРАТКАЯ ИНСТРУКЦИЯ ПО УСТАНОВКЕ

✓ Please Check

RU

UK

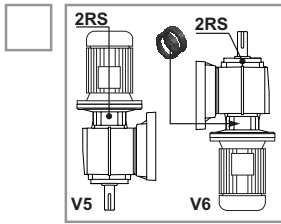

Отметьте, если редуктор будет использоваться в монтажных позициях V5 и V6. Будут установлены самосмазывающиеся подшипники 2RS (см. рисунок). Для монтажной позиции V6 мы рекомендуем использовать двойные входные сальники. Монтажная позиция V6 не рекомендуется для двухполюсных двигателей.

Please specify when ordering if reducer are used in Vertical V5 or V6 mounting position. We normally mount a 2rs self lubricated bearings (see picture). For V6 mounting we recommend double oil seals in the input side V6 positions for 2 poles motors.

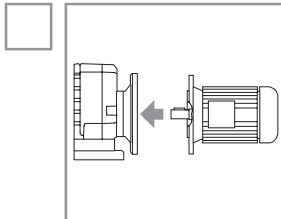

При монтаже двигателя на редуктор крепежные болты следует затягивать при соприкосновении поверхности двигателя с фланцем редуктора. После завершения сборки убедитесь в беспрепятственном вращении мотор-редуктора, повернув крыльчатку мотора рукой.

When mounting a motor to reducers, the fastening bolts should not be tightened until both the reducer flange and motor face are in contact. When mounting is complete check by manually rotating the motor's shaft to be sure the assembly turns freely.

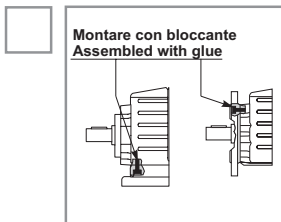

Если устройство эксплуатируется с частыми пусками, остановками и реверсированием хода, в качестве крепежных элементов следует использовать болты Loctite код 270 или подобные.

In applications where multiple starts, stops or reverses occur, it is advisable to use Loctite Code 270 or similar compounds on the fastening bolts of the output flange and feet.

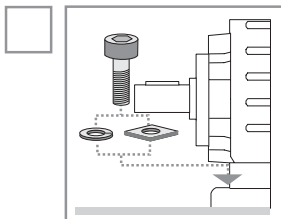

Производите монтаж редуктора на ровную поверхность, не подверженную вибрации. При высокой внешней радиальной нагрузке необходимо усилить опорную поверхность головки болта с помощью шайбы (см. рисунок).

Mount the reducer on a flat surface free of vibration. If high overhung loads are expected, it is advisable to reinforce bolt heads with washers as shown in picture.

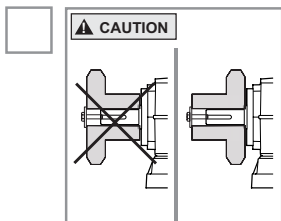

Убедитесь, что установка шкивов или болтов не станет причиной непредусмотренных внешних радиальных перегрузок редуктора.

Make sure that mounting of pulleys or pinions does not create overhung loads exceeding the capacity of the reducer.

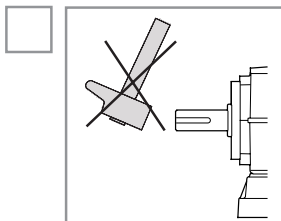

При установке элементов на вал редуктора следует избегать толчков и ударов, используя соответствующие съемники, которые крепятся с помощью резьбовых отверстий на торцах валов.

When mounting anything on the reducer's shaft, protect the bearings from impact by using the appropriate pullers and threaded holes in the end of the reducer shaft.

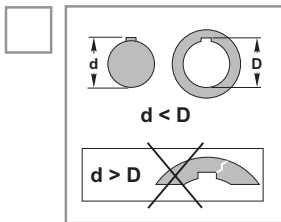

При монтаже элементов на вал редуктора необходимо использовать противозадирный и антиокислительный составы.

When mounting items to the reducer shaft, appropriate anti-seize and oxidizer compounds should be used, and keys dimensions are connect.

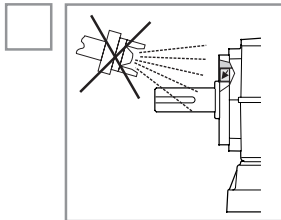

При окраске редуктора не допускайте попадания краски на обработанные поверхности и сальники.

If the reducer is to be painted, protect machined surfaces and oil seals from over-spray.



D

F

E

In der Bestellung muss spezifiziert werden, ob die Getriebe für die Einbaulagen V5чV6 vorgesehen sind, so dass ggf. Lager 2RS (abgeschirmte) und eventuell zusätzliche Dichtringe vorgesehen werden können. Für die Einbaulage V6 empfehlen wir die Montage von 2 Dichtringen (Einbaulage, von der bei 2-poligen Motoren abgeraten wird).

Die Passung an den Motor muss frei und gleitend erfolgen. Der Anzug der Befestigungsschrauben darf erst dann erfolgen, wenn die beiden Flanschen auf Kontakt liegen. Nach erfolgtem Zusammenbau muss durch ein manuelles Einwirken auf das Lüfterrad kontrolliert

Bei Applikationen, die durch häufige Starts/Stoppes oder Inversionen charakterisiert werden, sollten die Befestigungsschrauben der Flanschen mit Loctite Art. 270 oder Arexons Art. 35A42 blockiert werden.

Sicherstellen, dass die Befestigung des Getriebes auf einer festen, ebenen und schwingungsfreien Unterlage erfolgt. Sollten erhöhte Belastungen vorgesehen sein, sollten aufgebogene Zwischenlegscheiben unter dem Kopf der Schrauben für die Befestigung am Gestell verwendet werden.

Sich darüber vergewissern, dass die eventuelle Montage von überstehenden Ritzeln oder Riemenscheiben an den Wellen durch vorausgehende Überprüfungen der Zulässigkeit der daraus resultierenden Lasten bestätigt wird.

Bei der Montage von Ritzeln, Kupplungen oder Riemenscheiben an den Getriebe-Wellen sind durch die Anwendung angemessener Abzieher, die in den Gewindebohrungen an den Wellenenden verankert werden müssen, Stöße zu vermeiden.

In allen Passungen zwischen Welle/Nabe die Kontaktflächen mit angemessenen Antioxydationsmitteln einstreichen und überprüfen, dass die Federkeile nicht zu stark beansprucht werden, so dass ein Bruch der Nabe verhindert werden kann.

Während der eventuellen Lackierung die Dichtringe und die bearbeiteten Flächen schützen.

Préciser sur la commande si les réducteurs doivent être livrés pour des positions de montage V5чV6 pour pouvoir en prévoir les roulements correspondants 2RS (blindés) et les bagues d'étanchéité complémentaires. Pour la position V6 il est conseillé d'utiliser 2 bagues d'étanchéité (position non adaptée aux moteurs à 2 pôles).

L'accouplement au moteur doit s'avérer librement et sans points durs. Le serrage des vis de fixation ne doit s'effectuer que lorsque les deux flasques-bridés seront en contact. Assemblage terminé, contrôler que le moteur tourne librement en intervenant manuellement sur la pale de

Dans les applications caractérisées par de nombreux démarrages/arrêts ou inversions, il est conseillé de bloquer les vis fixant les flasques-bridés avec du Loctite code 270 ou bien de l'Arexons code 35A42.

S'assurer que la fixation du réducteur s'avère sur une base rigide, plane et sans vibrations. Si l'on envisage de fortes contraintes, utiliser des rondelles fendues en dessous de la tête des vis de fixation à la base.

S'assurer que tout montage en porte-à-faux de pignons ou poulies sur les arbres est bien validé par des vérifications, au préalable, sur l'admissibilité des charges qui en découlent.

Lors de la pose de pignons, joints de raccordement ou poulies sur les arbres du réducteur, éviter tous chocs en utilisant des extracteurs appropriés, ancrés aux taraudages existant en tête des arbres.

Dans tous les accouplements arbre / moyeu enduire les surfaces de contact avec des produits de protection anti-oxydation et vérifier l'absence de forçage sur les clavettes afin d'éviter la casse du moyeu.

En cours de peinture protéger les bagues d'étanchéité et les surfaces usinées.

Especificar en el pedido si los reductores serán utilizados en posición de montaje vertical V5-V6. Para estas posiciones van montados rodamientos cerrados 2RS, como se indica en la figura. En el montaje V6 sugerimos el uso de dos retenes en la entrada. Desaconsejamos el montaje en posición V6 con motor de 2 Polos.

El acoplamiento al motor debe ser libre y deslizante. El apriete de los tornillos de fijación, solo se llevara a cabo, cuando las dos bridas están en contacto. Una vez finalizado el montaje, controlar que el motor gira libremente, actuando manualmente sobre el ventilador.

En aplicaciones que se caractericen por numerosas arrancadas y paradas o inversiones, es aconsejable bloquear los tornillos de fijación de las bridas con Loctite cod. 270 y bien Arexons cod.34A42

Comprobar que la fijación del reductor haya sido efectuada sobre la base rígida, plana y no expuesta a vibraciones. Si se prevén elevadas exigencias utilizar arandelas de presión bajo la cabeza de los tornillos de fijación a la base.

En montajes de picones o poleas sobre el eje de salida en voladizo, asegurarse de la admisibilidad de los valores de carga radial resultante.

Al montar picones, juntas o poleas en los ejes del reductor evitar los golpes y usando extractores apropiados fijados en los orificios con rosca que hay en los extremos de los mismos ejes.

En los acoplamientos eje/cubo, utilizar protectores antioxidantes, y verificar que las chavetas no estén forzadas, para evitar la rotura del cubo.

Durante el pintado proteger los retenes y las superficies mecanizadas.



**Обслуживание  
Maintenance  
Wartung  
Entretien  
Mantenimiento**

Мотор-редукторы, залитые смазкой на весь срок службы, не требуют обслуживания. Для других типов редукторов необходимо периодически обновлять и поддерживать определенный уровень смазки.

Избегайте смешивания синтетической и минеральной смазок. Первую замену минеральной смазки необходимо производить через 150 часов эксплуатации, а каждую последующую замену - через 4000 часов.

Периодически осуществляйте проверку кожуха вентилятора на предмет засорения пылью и волокнами.

Необходимо периодически проверять люфт **моторов со встроенным тормозом и производить замену тормозной накладки.**

Также осуществляйте проверку тормозного момента с помощью моментомера.

Gearboxes that are lubricated for life do not require any maintenance. For others, the lubricant **needs to be periodically refilled** and eventually changed with a suitable grade.

Avoid mixing synthetic and mineral lubricants.

It is advisable to carry out **the first oil change** after 150 operating hours and the subsequent ones every 4000 operating hours.

From time to time check that the fan cowl is not clogged with dust or fibres.

**For brake motors** it is also necessary to periodically check the air gap and replace the brake lining if the values exceed permissible ones. Also check the brake torque using a torque meter.

**Хранение  
Stocking  
Lagerhaltung  
Stockage  
Almacenamiento**

- Для обеспечения надежного функционирования редуктора необходимо следовать следующим указаниям:
- **оберегайте устройство от высокого уровня влажности**
- **храните устройство в специальных шкафах**
- При длительном хранении залейте смазкой внешние детали устройства, которые могут быть подвержены окислению (валы и обработанные поверхности). Редукторы, не имеющие смазки, необходимо полностью залить маслом. Во время установки понизьте уровень смазки до требуемого.

In order to safeguard the efficiency of the gearboxes, it is required to observe the following indications:

- **stock the gearboxes in appropriate environments with a low humidity level**
- **Place the same possibly onto shelves**
- In case of prolonged stocking periods, **lubricate the external parts** which could be subject to oxidation (shafts and machined parts).

The non lubricated gearboxes should be completely filled up with oil. Oil level should then be reset to required levels during installation.

**Условия поставки  
Supply terms  
Lieferbedingungen  
Conditions de fourniture  
Condiciones de suministro**

Редукторы поставляются на следующих условиях:

- заранее подготовленные к установке на определенную монтажную позицию
- протестированы в соответствии с указанными спецификациями
- в соответствующей упаковке
- соприкасающиеся поверхности не окрашены
- без крепежных болтов и гаек двигателя в соответствии со стандартом IEC
- залиты смазкой (в соответствии с требованиями)
- окрашены (в соответствии с требованиями)
- укомплектованы рым-болтами

Gearboxes are supplied as follows:

- prearranged to be installed in the ordered mounting position
- tested as per internal specifications
- with appropriate packing
- coupling surfaces not painted
- without nuts and bolts for motor mounting as per IEC version
- already filled in with lubricant where specified
- already painted where specified
- already equipped with lifting eyebolts



## D

Getriebe mit Lebendauerschmierung benötigen keine Wartung.

Bei allen anderen Getrieben ist es notwendig, regelmäßig den Ölstand zu prüfen und ggf. nachzufüllen.

**ACHTUNG:**

Niemals mineralisches und synthetisches Öl vermischen!

Der erste Ölwechsel muss nach 150 Betriebsstunden, jeder weitere nach 4000 Betriebsstunden erfolgen.

Von Zeit zu Zeit ist zu prüfen:

- a) die Lüfterhaube des Motors nach Verschmutzung oder Verfüllung.
- b) bei Bremsmotoren die Bremse auf ordnungsgemäße Funktion und Wirkung.

Für sichere und effiziente Lagerhaltung sollten folgende Punkte beachtet werden:

- **Getriebe in geschützter Umgebung mit wenig Personenverkehr**
- **Bei längerer Lagerhaltung sollten die bearbeiteten Stahlflächen mittels Fett vor Rost geschützt werden.**
- Getriebe ohne Ölfüllung sollten vor Lagerung zuerst mit Öl werden.

Die Ölmenge muss beim Einbau korrigiert werden.

Die Getriebe werden folgendemalen geliefert:

- vorbereitet für die bestellte Einbaulage
- geprüft nach den internen Vorschriften
- mit beigefügtem Zubehör
- ohne Schrauben und Muttern bei Lieferung ohne Motor
- Bereits mit Schmiermittel ausgestattet (sofern vorgesehen)
- Bereits lackiert (sofern vorgesehen).
- Bereits mit Transportöse ausgestattet (sofern vorgesehen)

## F

Les réducteurs lubrifiés à vie ne nécessitent pas d'entretien.

Pour les autres il est nécessaire **d'effectuer une vérification périodique du niveau de l'huile** éventuellement en le remplaçant avec un type compatible.

Vérifier de mélanger les huiles synthétiques avec les huiles minérales.

Effectuer **le premier changement de l'huile** après 150 heures et les changements successifs après 4000 heures de fonctionnement.

Vérifier que le capot ventilateur du moteur ne soit pas bouché par de la poussière, des filaments ou d'autres corps.

**Pour les moteurs auto-freinants** contrôler périodiquement la valeur de l'entrefer en effectuant le remplacement du ferodo si les valeurs sont supérieures à celles admises. Vérifier le couple de freinage avec une clé dynamométrique.

Pour garantir l'efficacité des réducteurs stockés il est nécessaire d'observer les indications suivantes:

- **les conserver dans des endroits avec un bas niveau d'humidité**
- **les disposer sur des palettes ou des plates-formes**
- pour des périodes de stockage prolongées, **lubrifier avec de la graisse** les parties extérieures qui pourraient être sujettes à oxydation (arbres et surfaces travaillées).

Pour les réducteurs fournis sans lubrifiant nous conseillons de les remplir complètement d'huile. Lors de l'installation, ajuster le niveau.

Les réducteurs sont fournis comme décrit ci-après:

- prêts pour être installés dans la position de montage définie lors de la commande
- testés selon les spécifications internes
- avec un emballage approprié
- les surfaces d'accouplement non peintes
- équipés d'écrous et de boulons pour montage moteurs pour la version IEC
- déjà pourvus de lubrifiant (la version IEC)
- déjà vernis (la version IEC)
- déjà pourvus de œillet de soulèvement (la version IEC)

## E

Los reductores con lubricación permanente no precisan mantenimiento.

Para los demás es necesario **controlar periódicamente el nivel del aceite** y, eventualmente, rellenar con uno de tipo compatible.

Evitar la mezcla de aceites sintéticos con aceites minerales.

Effectuar **el primer cambio de aceite** después de 150 horas. Efectuar el primer cambio de aceite después de 4000 horas de funcionamiento.

Comprobar que la rejilla trasera del motor no está obstruida por polvo, hilos u otras cosas.

**En los motores autofrenantes** controlar periódicamente el valor del entrehierro efectuando la sustitución del ferodo si los valores superan los admitidos.

Verificar el par del freno con llave dinamo-métrica.

Para garantizar el buen estado de los reductores recibidos, deben cumplirse las siguientes indicaciones:

- **conservarlos en locales resguardados** con un bajo nivel de humedad
- **disponerlos sobre estanterías o plataformas**
- para largos periodos de almacenamiento, **lubricar con grasa** las partes exteriores que podrían oxidarse (ejes y superficies mecanizadas).

Para los reductores suministrados sin lubricante, se aconseja llenarlos totalmente de aceite, restableciendo, obviamente, su correcto nivel durante la instalación.

Los reductores se suministran del siguiente modo:

- ya listos para su instalación en la posición de montaje como se ha solicitado en el pedido
- rodados según las normas internas
- específicamente embalados
- las superficies de acoplamiento no están pintadas
- desprovistos de tuercas y tornillos para el montaje motores para la versión IEC
- Provistos de lubricante (donde este previsto)
- Pintados (donde este previsto)
- Provistos de argolla de elevación (donde este previsto)



СПИСОК ЗАПЧАСТЕЙ / SPARE PARTS LISTS / ERSATZTEILLISTE  
LISTES PIÈCES DE RECHANGE / LISTA DE REPUESTO



Уплотнители Oil seals	№	311	411	511
	15	TC 30x47x7	TC 30x47x7	TC 30x47x7
24	SC 25x40x7	SC 35x47x7	SC 35x47x7	SC 45x62x7

Подшипники Bearings	№	311	411	511
	02	6204	6204	6205
	03	6202	6004	6205
	04	6002	6002	6004
06	6005	6007	6009	

Прокладки Gaskets	№	311	411	511
	07	C30.0.302	C30.0.302B	23.00.302
16	311.0.301	311.0.301	511.0.301	

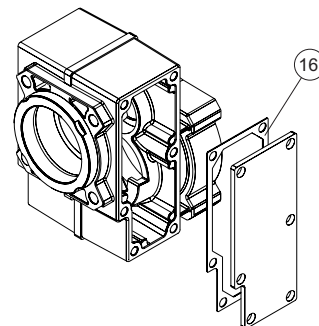
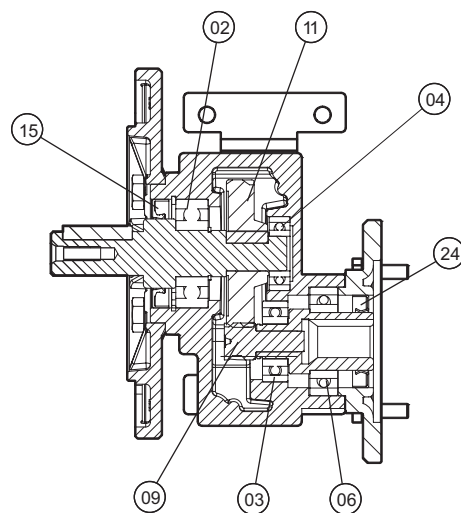

Уплотнители Oil seals	№	202	302	452
	75	SC 25x40x7	SC 35x47x7	SC 40x62x7
78	TC 30x47x7	TC 30x47x7	TC 45x62x7	

Подшипники Bearings	№	202	302	452
	35a	6200	6202	6202
	35b	6200	6202	6202
	36	6005	6007	6009
	37	6202	6004	6205
	38	6202	6202	6205
39	6204	6204	6206	

Прокладки Gaskets	№	202	302	452
	07	C30.0.301	C30.0.301	C45.0.301
16	050.0.301	022.0.302	23.00.302	

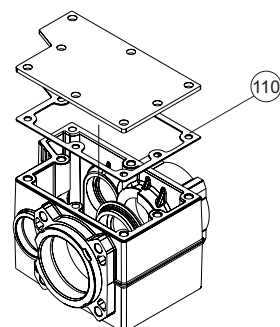
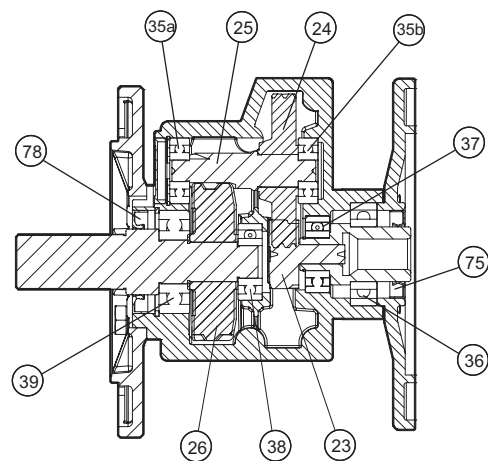

СПИСОК ЗАПЧАСТЕЙ / SPARE PARTS LISTS / ERSATZTEILLISTE  
LISTES PIÈCES DE RECHANGE / LISTA DE REPUESTO



2 ступени / 2 steps



Уплотнители Oil seals	№	402	502	602
	75	SC 35x47x7	SC 45x62x7	SC 45x62x7
75*	SC 35x47x7	—	—	
76*	SC 40x52x7	SC 50x75x7	SC 50x75x7	
77*	SC 25x47x7	SC 40x52x7	SC 50x62x7	
78	TC 30x52x7	TC 35x72x7	TC 45x85x7	

Подшипники Bearings	35a	6202 (6300**)	6302	6204
	35b	6202	6204	6304
	36	6007	6009	6009
	37	6004	6205	6205*
	38	6204	6205	6206
	39	6205	6207	6209

Прокл. Gaskets	110	C40.0.301	C50.0.301B	C60.0.301
	111	022.0.302	23.00.302	23.00.302
	114	C40.0.300	C50.0.300	C60.0.300

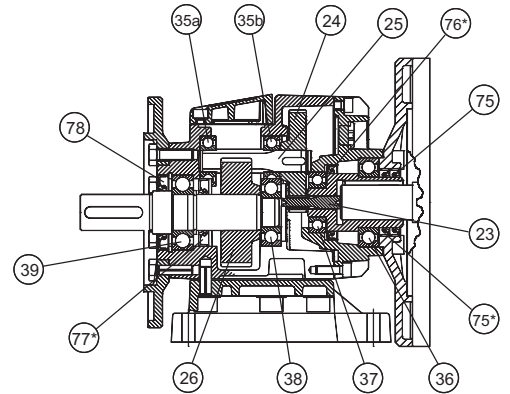

\* По запросу / On request / Auf Wunsch / Sur demande / Sobre pedido  
\*\* При некоторых знач. передат. числа / On some ratios / In folgenden Untersetzungen

Уплотнители Oil seals	№	403	503	603
	77*	SC 25x47x7	SC 40x52x7	SC 50x62x7
78	TC 30x52x7	TC 30x72x7	TC 45x85x7	
80a	SC 25x40x7	SC 35x47x7	SC 35x47x7	
81*	SC 28x40x7	SC 40x52x7	SC 40x52x7	

Подшипники Bearings	35a	6202 (6300**)	6302	6204
	35b	6202	6204	6304
	36	6005	6007	6007
	37	6202	6004	6004
	38	6204	6205	6206
	39	6205	6207	6209
	41a	6201	6201	6301
	41b	6201	6301	6201

Прокл. Gaskets	110	C40.0.301	C50.0.301	C60.0.301
	112	050.0.301	022.0.302	022.0.302
	114	C40.0.300	C50.0.300	C60.0.300

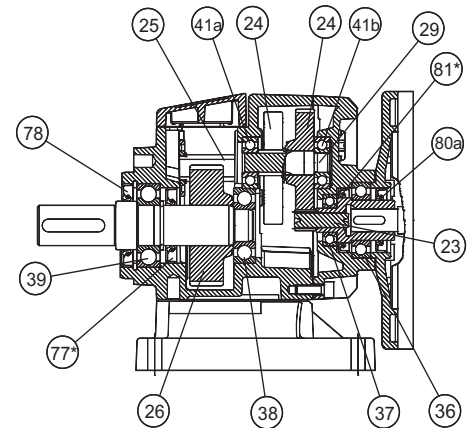

3 ступени / 3 steps

Уплотнители Oil seals	№	402C	602C
	75	SC 35x47x7	SC 45x62x7
75*	SC 35x47x7	—	
76*	SC 40x52x7	SC 50x75x7	
77*	SC 25x47x7	SC 50x62x7	
78	TC 30x52x7	TC 45x85x7	

Подшипники Bearings	35a	6202	6204
	35b	6202	6304
	36	6007	6009
	37	6004	6205
	38	6204	6206
	39	6205	6209

Прокл. Gaskets	110	C40.0.301	C50.0.301
	111	022.0.302	023.0.302
	114	C40.0.300C	C60.0.300C

\* По запросу / On request / Auf Wunsch / Sur demande / Sobre pedido

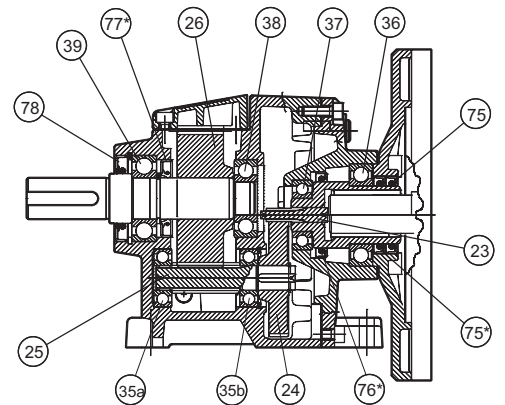

2 ступени / 2 steps



Уплотнители Oil seals	№	403C	603C
	75	SC 35x47x7	SC 35x47x7
75*	SC 35x47x7	SC 35x47x7	
77*	SC 25x47x7	SC 50x68x7	
78	TC 30x52x7	TC 45x85x7	
81*	SC 40x52x7	SC 40x52x7	

Подшипники Bearings	35a	6202	6204
	35b	6202	6304
	36	6007	6007
	37	6004	6004
	38	6204	6206
	39	6205	6209
	41a	6201	6301
41b	6201	6201	

Прокл. Gaskets	110	C40.0.301	C50.0.301
	111	022.0.302	022.0.302
	114	C40.0.300C	C60.0.300C

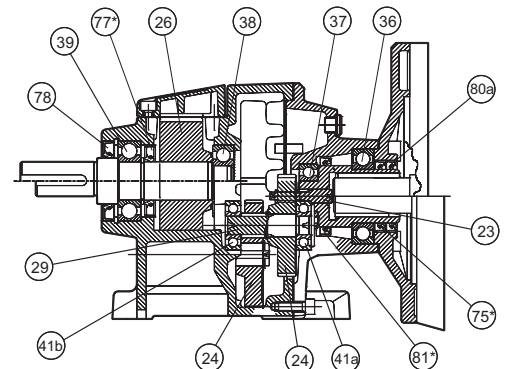

3 ступени / 3 steps



ЭЛЕКТРОДВИГАТЕЛИ / ELECTRIC MOTORS / ELEKTROMOTOREN  
MOTEURS ÉLECTRIQUES / MOTORES ELÉCTRICOS

Размеры и технические характеристики

Dimensions and technical data

Abmessungen und Auswahltabellen

Dimensions et caractéristiques techniques

Dimensiones y datos técnicos

B5

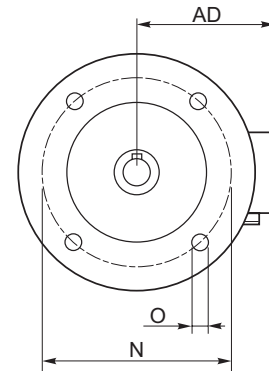
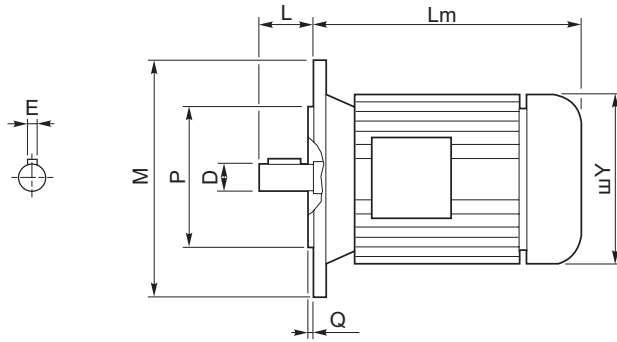

B14

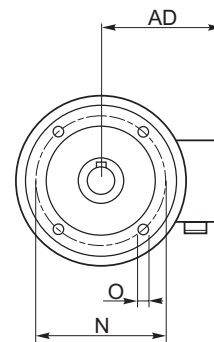
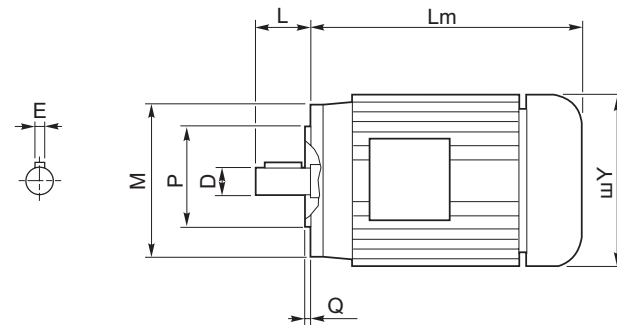

Наружные размеры определяются производителем.  
Outer dimensions may be different according to manufacturers.  
Den jeweiligen Herstellern gemäß können die Außenmaße unterschiedlich ausfallen.  
Les dimensions extérieures peuvent changer en fonction des différents fabricants.

	2 полюса / poles			4 полюса / poles			6 полюсов / poles			B5-B14					B5					B14					Kr	
	kW	Nm	A <sub>(400V)</sub>	kW	Nm	A <sub>(400V)</sub>	kW	Nm	A <sub>(400V)</sub>	D	E	L	Lm	Y	AD	P	N	M	O	Q	P	N	M	O		Q
56 A	0.09	0.32	0.38	0.06	0.44	0.27	—	—	—	9	3	20	179	108	96	80	100	120	9	2.5	50	65	80	M5	2.5	2.7
56 B	0.12	0.42	0.46	0.09	0.67	0.37	—	—	—																	2.9
63 A	0.18	0.63	0.60	0.12	0.84	0.50	0.09	0.99	0.57	11	4	23	185	120	99	95	115	140	9.5	3	60	75	90	M5	2.5	3.8
63 B	0.25	0.87	0.76	0.18	1.30	0.69	0.12	1.32	0.74																	4.2
71 A	0.37	1.30	1.00	0.25	1.70	0.91	0.18	1.90	0.80	14	5	30	206	130	104	110	130	160	9.5	3.5	70	85	105	M6	2.5	5.9
71 B	0.55	1.90	1.54	0.37	2.52	1.14	0.25	2.72	1.10				225	141	107											6.5
80 A	0.75	2.60	1.85	0.55	3.77	1.51	0.37	3.84	1.18	19	6	40	256	159	127	130	165	200	11.5	3.5	80	100	120	M6	3	8.5
80 B	1.1	3.90	2.64	0.75	5.11	2.57	0.55	5.84	1.80																	10
90 S	1.5	5.00	3.31	1.1	7.45	2.78	0.75	7.92	2.32	24	8	50	255	170	135	130	165	200	11.5	3.5	95	115	140	M8	3	12.5
90 L	2.2	7.50	4.46	1.5	10.2	3.61	1.1	11.6	3.45				280													15
100 LA	3.0	10.0	6.28	2.2	14.8	5.07	1.5	15.4	3.88	28	8	60	299	190	148	180	215	250	13	4	110	130	160	M8	3.5	20
100 LB	—	—	—	3.0	20.1	6.66	—	—	—				22													
112 M	4.0	13.4	8.10	4.0	26.7	8.55	2.2	22.6	5.30				321	210	164											35
132 S	5.5	18.3	11.2	5.5	36.5	11.4	3.0	30.2	7.20	38	10	80	365	244	180	230	265	300	14	4	130	165	200	M10	4	41
	7.5	24.9	15.3										51													
132 M	—	—	—	7.5	49.4	15.0	4.0	40.0	9.13				403													51





**Защита**

Стандарт IP54  
Необходимо указать в заказе, если требуется соответствие стандарту IP55 или выше.

**Protection**

Standard IP54  
To be specified upon placing the order if IP55 or higher protection is required

**Schutzart**

IP54 Standard.  
IP55 oder höher im Auftrag angeben.

**Degré de protection**

IP54 standard.  
Au moment de la commande, spécifiez si vous souhaitez l'IP55 ou supérieur.

**Grado de protecciyón**

IP54 standard.  
Especificar al efectuar el pedido el IP55 y superior.

**Изоляция**

Стандарт CI.F  
Необходимо указать в заказе, если требуется другой тип изоляции.

**Insulation**

Standard CI.F  
To be specified upon placing the order if different insulation is required.

**Isolierung**

CI.F Standard.  
Davon abweichende Isolierungsklasse im Auftrag angeben

**Isolement**

CI.F standard.  
Au moment de la commande, spécifiez si vous souhaitez une classe d'isolement différente.

**Aislamiento**

CI.F standard.  
Especificar al efectuar el pedido la clase diferente de aislamiento.

Класс изоляции обмоток / Insulation Isolierung / Isolement / Aislamiento		E	B	F	H
Макс. темп.	C°	120°	130°	155°	175°
	F*	248°	266°	311°	347°

**Соединения**

**Connections**

**Verbindungselemente**

**Branchements**

**Conexiones**

Трёхфазный асинхронный односкоростной  
Threephase asynchronous single polarity  
Asynchronmotor 3-ph eine Drehzahl  
Moteur triphasé a une vitesse  
Asincrono trifasico de una velocidad

Трёхфазный асинхронный двухскоростной  
Threephase asynchronous single polarity  
Asynchronmotor 3-ph doppelte Drehzahl  
Moteur triphasé a deux vitesses  
Asincrono trifasico de dos velocidades

Однофазный асинхронный  
Single phase asynchronous  
Einphasen-Asynchronmotor  
Moteur monophasé  
Asincrono monofasico

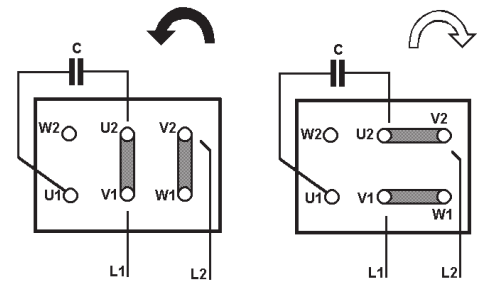
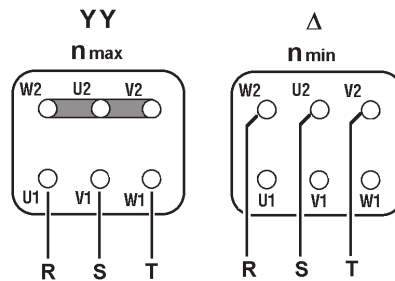
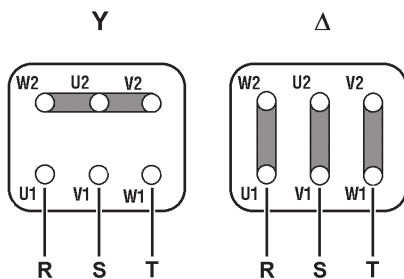

### Прочитайте внимательно

Данная информация позволит обеспечить безопасную и эффективную эксплуатацию вашего устройства. Ознакомьтесь со всеми указаниями перед началом эксплуатации редуктора. Неправильная установка, обслуживание или эксплуатация могут привести к получению серьезных травм или поломке редуктора.

### ВНИМАНИЕ!

- Для использования редукторов в пассажирских лифтах или других устройствах, которые служат для перемещения людей, необходимо получить наше письменное разрешение.
  - Рабочие нагрузки не должны превышать указанных в данном каталоге.
  - Только покупатель отвечает за определение пригодности устройства для выполнения соответствующих задач. Производитель не дает каких-либо явных или подразумеваемых гарантий в отношении пригодности устройства для определенных целей.
  - Пользователь обязан защитить вал и любые приводные механизмы, установленные на нем, с помощью предохранительного кожуха. Также пользователь должен следовать местным правилам по технике безопасности. Неправильная эксплуатация устройства может привести к серьезным травмам персонала и повреждению оборудования.
  - Перегрев смазки или редуктора может привести к возгоранию. Будьте очень осторожны при демонтаже смазочных заглушек и вентиляей.
  - Перед осуществлением сервисного обслуживания или демонтажа деталей отключите от источника питания. Заблокируйте его и повесьте предупредительную табличку во избежание случайного запуска.
  - Редукторы не являются отказоустойчивыми или самоотключающимися устройствами. Для обеспечения данной функции необходимо использовать независимый блокиратор. Не следует использовать редукторы в качестве тормозного механизма.
  - Любые тормоза, которые используются вместе с редуктором, должны иметь такие размеры и расположение, чтобы нагрузки на редуктор не превышали указанных в данном каталоге.
  - Такие элементы, как рым-болты, должны использоваться исключительно для вертикального подъема устройства, а не для фиксации деталей или двигателей.
  - Использование смазки с присадками EP для элементов с ограничителем обратного хода может привести к серьезным травмам персонала и поломке редуктора или другого оборудования.
- Высокие рабочие нагрузки на подшипники и валы могут привести к их преждевременному износу или повреждению.

**Наша компания не несет ответственность за любой прямой или косвенный ущерб, вызванный неправильной эксплуатацией устройства или несоблюдением инструкций, приведенных в настоящем документе.**

### Please Read Carefully

The following WARNING and CAUTION information is supplied to you for your protection and to provide you with many years of trouble free and safe operation of your product. Read ALL instructions prior to operating reducer. Injury to personnel or reducer failure may be caused by improper installation, maintenance or operation.

### WARNING:

- Written authorization required to operate or use reducers in man lift or people moving devices.
- Check to make certain application does not exceed the allowable load capacities published in the current catalog.
- Buyer shall be solely responsible for determining the adequacy of the product for any and all uses to which Buyer shall apply the product. The application by Buyer shall not be subject to any implied warranty of fitness for a particular purpose.
- For safety, Buyer or User should provide protective guards over all shaft extensions and any moving apparatus mounted thereon. The User is responsible for checking all applicable safety codes in his area and providing suitable guards. Failure to do so may result in bodily injury and/or damage to equipment.
- Hot oil and reducers can cause severe burns. Use extreme care when removing lubrication plugs and vents.
- Make certain that the power supply is disconnected before attempting to service or remove any components. Lock out the power supply and tag it to prevent unexpected application power.
- Reducers are not to be considered fail safe or self-locking devices. If these features are required, a properly sized, independent holding device should be utilized. Reducers should not be used as a brake.
- Any brakes that are used in conjunction with a reducer must be sized or positioned in such a way so as to not subject the reducer to loads beyond the catalog rating.
- Lifting supports including eyebolts are to be used for vertically lifting the gearbox only and not other associated attachments or motors.
- Use of an oil with an EP additive on units with backstops may prevent proper operation of the backstop. Injury to personnel, damage to the reducer or other equipment may result.
- Overhung loads subject shaft bearings and shafts to stress which may cause premature bearing failure and or shaft breakage from bending fatigue, if not sized properly.

**Our company will not be responsible for any direct or indirect damages, caused by a wrong use of the products or for not observing the catalogue indication**

# INNOVARI



## Производство самых современных редукторов

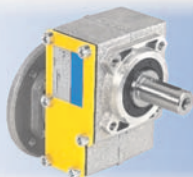

Одноступенчатые  
цилиндрические редукторы

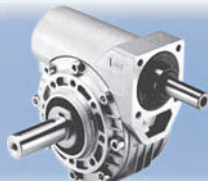

Червячные  
редукторы



Компактные  
насадные редукторы



Ваш ближайший дилер



АУДИТ - ПРЕДЛОЖЕНИЕ - СЕРВИС

**ГЛАВАВТОМАТИКА**

454018, г Челябинск, ул. Кислицына, 100  
Тел/факс (351) 729-82-00 (многоканальный)  
сот: +7 952 50 57 702  
sale@mega-sensor.ru, www.mega-sensor.ru  
<http://главаавтоматика.рф>